



**Department of
Design and
Construction**

**THE CITY OF NEW YORK
DEPARTMENT OF DESIGN AND
CONSTRUCTION**

DIVISION OF INFRASTRUCTURE

30-30 THOMSON AVENUE
LONG ISLAND CITY, NY, 11101
TEL: 718.391.1000
WEB: www.nyc.gov/ddc

TO BE FILLED IN BY THE BIDDER:

BIDDER'S NAME:

BID SECURITY (CIRCLE ONE):

BID BOND / CERTIFIED CHECK

NUMBER OF ADDENDUMS RECEIVED
AND ATTACHED TO BID:

____ ADDENDUMS

DDC CLIENT AGENCY:

**THE DEPARTMENT OF
ENVIRONMENTAL PROTECTION**

PREPARED BY:

IN-HOUSE DESIGN

DATE PREPARED:

09/12/2019

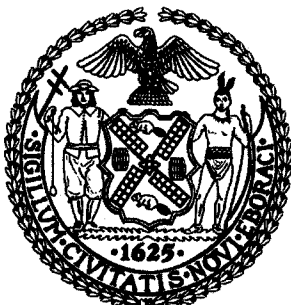

VOLUME 1 OF 3 BID BOOKLET

FOR FURNISHING ALL LABOR AND MATERIALS
NECESSARY AND REQUIRED FOR:

PROJECT ID: SEQBN11

**RECONSTRUCTION OF EXISTING SEWERS,
NORTH QUEENS**

TOGETHER WITH ALL WORK INCIDENTAL THERETO
**BOROUGH OF QUEENS
CITY OF NEW YORK**

20-011



Lorraine Grillo
Commissioner

Jamie Torres-Springer
First Deputy Commissioner

Justin Walter
Chief Administrative Officer
Administration

Nicholas Mendoza
Agency Chief Contracting Officer

Lorraine Holley
Deputy ACCO

May 28, 2020

CERTIFIED MAIL - RETURN RECEIPT REQUEST

ADC CONSTRUCTION LLC

58-08 48th Street
Maspeth, NY 11378

RE: FMS ID: SEQBN11
E-PIN: 85020B0005001
DDC PIN: 8502019SE0033C
RECONSTRUCTION OF EXISTING
SEWERS, NORTH QUEENS
NOTICE OF AWARD

Dear Contractor:

You are hereby awarded the above referenced contract based upon your bid in the amount of \$7,586,047.70 submitted at the bid opening on December 05, 2019. Within ten (10) days of your receipt of this notice of award, you are required to take the actions set forth in Paragraphs (1) through (3) below. For your convenience, attached please find a copy of Schedule A of the General Conditions to the Contract, which sets forth the types and amounts of insurance coverage required for this contract.

- (1) Execute two copies of the Agreement in the Contracts Unit, 30-30 Thomson Avenue, 1st Floor, Long Island City, New York (IDCNY Building). A Commissioner of Deeds will be available to witness and notarize your signature. The Agreement must be signed by an officer of the corporation or a partner of the firm.
- (2) Submit to the Contracts Unit two properly executed performance and payment bonds. If required for this contract, copies of performance and payment bonds are attached.
- (3) Submit to the Contracts Unit the following insurance documentation: (a) original certificate of insurance for general liability in the amount required by Schedule A, and (b) original certificates of insurance or other proof of coverage for workers' compensation and disability benefits, as required by New York State Law. The insurance documentation specified in this paragraph is required for registration of the contract with the Comptroller's Office.

On or before the contract commencement date, you are required to submit all other certificates of insurance and/or policies in the types and amounts required by Schedule A. Such certificates of Insurance and/or policies must be submitted to the Agency Chief Contracting Office, Attention: Risk Manager, Fourth Floor at the above indicated department address.

Your attention is directed to the section of the Information for Bidders entitled "Failure to Execute Contract". As indicated in this section, in the event you fail to execute the contract and furnish the required bonds within the (10) days of your receipt of this notice of award, your bid security will be retained by the City and you will be liable for the difference between your bid price and the price for which the contract is subsequently awarded, less the amount of the bid security retained.

As of August 16, 2019, please be advised that Contract Site Safety Plans for DDC projects must be submitted through DDC's online Site Safety Plan (SSP) application (available via our Agency Portal – *DDC Anywhere*).

To create an account and begin your Site Safety Pan submission using SSP, click on the link below:

DDC Portal <https://ddcanywhere.nyc/Registration/Registration>

For questions regarding this web-based application, please contact DDC via email at: appsupport@ddc.nyc.gov.

Sincerely,

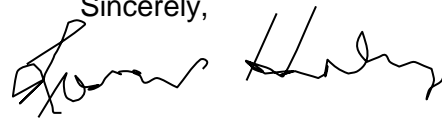

Lorraine Holley
Deputy ACCO



NOTICE TO BIDDERS

Pre-Bid Questions (PBQs)

Please be advised that PBQs should be submitted to the Agency Contact Person (CSB_projectinquiries@ddc.nyc.gov) at least five (5) business days (by 5:00 PM EST) prior to the bid opening date as indicated in BID INFORMATION, page A-5 and SCHEDULE B, page A-37, VOLUME 1 OF 3 of this BID BOOKLET.

All PBQs must reference the Project ID. If a bidder has multiple PBQs for the same Project ID, the PBQs must be numbered sequentially, even if they are submitted separately.

NYC Contract Financing Loan Fund

Loans at a 3% annual interest rate to perform on New York City contracts

If your business is working as a prime or subcontractor on a project with a City agency or City-funded entity, you may be eligible for a Contract Financing Loan from a participating lender coordinated with the NYC Department of Small Business Services (SBS). Loan repayment terms align with the contract payment schedule.

Loans of up to \$500,000 at an annual interest rate of 3% are available to eligible* businesses to perform on New York City contracts. Closing fees apply.

*To be eligible for a loan, you must:

- ✓ Have an operating business, AND
- ✓ Be applying for financing as a prime or sub-contractor to use toward a contract with a City agency or City-funded entity.
- ✓ Additional Eligibility requirements may also apply.

How it works:

Step 1: Fill out the Contract Financing inquiry form at nyc.gov/contractfinancing

Step 2: If Eligible, a participating lender will contact you within two business days.

Step 3: Begin the loan application process

For more information: **Call 311** or visit nyc.gov/contractfinancing

(NO FURTHER TEXT ON THIS PAGE)

NYC Bond Collateral Assistance Fund

If your business is bidding or planning to bid on a project as a prime or subcontractor with a City agency or the NYC Economic Development Corporation (NYCEDC) and the project requires surety bonding, you may be eligible* to receive up to **\$500,000 in Collateral Assistance to enhance your surety bond application** from a participating bond service provider coordinated with the NYC Department of Small Business Services (SBS).

*To be eligible, you must:

- ✓ Have an operating construction business, AND
- ✓ Be bidding or planning to bid as a **prime or subcontractor** on a contract with a City agency or NYCEDC that requires bonding
- ✓ Additional Eligibility requirements may apply.

How it works:

Step 1: Fill out the Bond Collateral Assistance Fund inquiry form at nyc.gov/bondfund

Step 2: If Eligible, the bond service provider will contact you within two business days

Step 3: Begin the bond application process

For more information: **Call 311** or visit nyc.gov/bondfund

(NO FURTHER TEXT ON THIS PAGE)

CITY OF NEW YORK
DEPARTMENT OF DESIGN AND CONSTRUCTION
DIVISION OF INFRASTRUCTURE

TABLE OF CONTENTS

NOTICE TO BIDDERS	i
TABLE OF CONTENTS	iii
A. BID BOOKLET	A-1
BID INFORMATION	A-1
SPECIAL NOTICE TO BIDDERS	A-3
BID INFORMATION (ATTACHMENT 1).....	A-5
SPECIAL EXPERIENCE REQUIREMENTS.....	A-7
M/WBE PROGRAM: M/WBE UTILIZATION PLAN	A-10
PRE-AWARD PROCESS	A-18
PASSPort COMPLIANCE.....	A-20
CONSTRUCTION EMPLOYMENT REPORT	A-20
REQUIRED FORMS	A-21
BID FORM.....	A-23
AFFIRMATION.....	A-28
BID BONDS	A-29
QUALIFICATION FORM	A-33
SCHEDULE B: M/WBE UTILIZATION PLAN.....	A-37
APPRENTICESHIP PROGRAM REQUIREMENTS	A-44
PROJECT REFERENCE FORMS.....	A-47
SAFETY QUESTIONNAIRE.....	A-51
IRAN DIVESTMENT ACT COMPLIANCE RIDER	A-55
B. BID SCHEDULE (B-PAGES).....	B-1
BID SCHEDULE.....	B-3

(NO TEXT ON THIS PAGE)

CITY OF NEW YORK
DEPARTMENT OF DESIGN AND CONSTRUCTION
DIVISION OF INFRASTRUCTURE

A. BID BOOKLET

BID INFORMATION

(NO TEXT ON THIS PAGE)

SPECIAL NOTICE TO BIDDERS

BID SUBMISSION REQUIREMENTS

THE FOLLOWING DOCUMENTS ARE TO BE COMPLETED AND SUBMITTED WITH THE BID:

- (1) Bid Schedule (Page B-3)
- (2) Bid Form, including Affirmation (Page A-23)
- (3) Bid Security (if required, see Bid Information on Page A-5)
- (4) Schedule B: M/WBE Utilization Plan (Page A-37, if participation goals have been established)

FAILURE TO SUBMIT THE ITEMS LISTED ABOVE WILL RESULT IN THE DISQUALIFICATION OF THE BID.

- (5) Bidder's Certification of Compliance with Iran Divestment Act (Page A-55)
- (6) Special Experience Requirements (Page A-7 & A-8, if applicable)
- (7) Apprenticeship Program Requirements (Page A-44, if applicable)
- (8) Safety Questionnaire (Page A-51)
- (9) Construction Employment Report (Page A-20 if bid is \$1,000,000 or more)
- (10) Any addenda issued prior to the receipt of bids

FAILURE TO SUBMIT THE ITEMS LISTED ABOVE MAY RESULT IN THE DISQUALIFICATION OF THE BID.

NOTES:

- (1) All of the above referred to blank forms to be completed and submitted with the bid are included in the BID BOOKLET, page numbers as noted above.
- (2) If the bidder has any questions or requires additional information, please contact the Agency Contact Person noted on Attachment 1 (Page A-5 of this Bid Booklet).
- (3) **PASSPort Compliance:** The Bidder is advised that Vendex Questionnaires and procedures have been replaced by the PASSPort system. Compliance with PASSPort is mandatory for contract Award. PASSPort details are set forth on Page A-20 of this Bid Booklet.
- (4) **SPECIAL EXPERIENCE REQUIREMENTS:** The Bidder is advised that Special Experience Requirements may apply to this contract. Such requirements are set forth beginning on Page A-7 of this Bid Booklet.

(NO TEXT ON THIS PAGE)

BID INFORMATION (ATTACHMENT 1)

PROJECT ID: SEQBN11

PIN: 8502019SE0033C

Description and Location of Work:

RECONSTRUCTION OF EXISTING SEWERS, NORTH QUEENS

Together With All Work Incidental Thereto
BOROUGH OF QUEENS
CITY OF NEW YORK

Documents Available at: 30-30 Thomson Avenue
First Floor Bid Procurement Room
Long Island City, New York 11101
8:30 A.M. to 4:00 P.M. – Monday through Friday

Submission of Bids to: 30-30 Thomson Avenue
First Floor Bid Procurement Room
Long Island City, New York 11101
Before 11:00 A.M. on **December 5th 2019**

Bid Opening: 30-30 Thomson Avenue
First Floor Bid Procurement Room
Long Island City, New York 11101
Time and Date: 11:00 A.M. on **December 5th 2019**

Pre-Bid Conference: Yes: _____ No: X
If Yes, Mandatory: ___ Optional: _____
Time and Date: _____
Location: _____

Bid Security: Bid Security is required in the amount set forth below; provided, however, bid security is not required if the TOTAL BID PRICE set forth on the Bid Form is less than \$ 1,000,000.00.
(1) Bond in an amount not less than 10% of the TOTAL BID PRICE set forth on the Bid Form, OR
(2) Certified Check in an amount not less than 2% of the TOTAL BID PRICE set forth on the Bid Form.

Performance and Payment Security: Required for contracts in the amount of \$1,000,000 or more. Performance Security and Payment Security shall each be in an amount equal to 100% of the Contract Price.

Agency Contact Person: Lorraine Holley
Phone: 718-391-2601, Fax 718-391-2627
Email: CSB_projectinquiries@ddc.nyc.gov



For questions about site accessibility, please contact our disability services facilitator at (718) 391-2815 or via email at accessibility@ddc.nyc.gov.

(NO TEXT ON THIS PAGE)

SPECIAL EXPERIENCE REQUIREMENTS

(A) SPECIAL EXPERIENCE REQUIREMENTS FOR THE BIDDER:

The Special Experience Requirements set forth below apply to the bidder. Compliance with such Special Experience Requirements will be determined solely by the City prior to an award of contract. Failure to comply with the Special Experience Requirements will result in rejection of the bid as non-responsive.

The requirements in this Section (A) apply to this contract where indicated by a blackened box (■).

- The bidder must, within the last seven (7) consecutive years prior to the bid opening, have successfully completed in a timely fashion at least one (1) project similar in scope and type to the required work. Such prior project may have been performed as a prime contractor, subcontractor or sub-subcontractor.

The Special Experience Requirements next to the blackened box below apply to the bidder. If the bidder intends to perform such work itself, it must demonstrate compliance with the Special Experience Requirements. If the bidder intends to subcontract this work, the proposed subcontractor or sub-subcontractor must demonstrate compliance with the Special Experience Requirements. The contractor, subcontractor or sub-subcontractor (hereinafter referred to as the "Entity") that will perform any specific area of work indicated by the blackened box below, may have performed the required prior project(s) as a prime contractor, subcontractor or sub-subcontractor. Once approved, no substitution will be permitted, unless the qualifications of the proposed replacement have been approved in writing in advance by the City.

- Trunk Water Main Work:** The Entity that will perform the trunk water main work must, within the last seven (7) consecutive years prior to the bid opening, have successfully completed in a timely fashion at least one (1) project similar in scope and type to the required work.
- Best Management Practice Work:** Best Management Practice ("BMP") Work is any item of work in the Bid Schedule that begins with the prefix "BMP". The Entity that will perform any BMP Work must, within the last five (5) consecutive years prior to the bid opening, have successfully completed in a timely fashion at least three (3) projects similar in scope and type to the required work.
For professional services in connection with BMP Work (i.e., monitoring and reporting services), the individual who will perform the required services must, within the last five (5) consecutive years prior to the bid opening, have successfully completed in a timely fashion at least three (3) projects similar in scope and type to the required work. Additional requirements are set forth below.
 - The individual serving as the Restoration Specialist (Construction Monitor) must be a Registered Landscape Architect licensed by the state of New York, or must have equivalent professional experience.
 - The individual serving as the Erosion and Sediment Control Licensed/Certified Professional must be a Certified Professional in Erosion and Sediment Control (CPESC), certified by CPESC, Inc.
- Micro-Tunneling/Pipe Jacking Work:** The Entity that will perform the micro-tunneling/pipe jacking work must, within the last five (5) consecutive years prior to the bid opening, have successfully completed in a timely fashion at least two (2) projects similar in scope and type to the required work.
- OTHER:** _____

(B) SPECIAL EXPERIENCE REQUIREMENTS FOR SPECIFIC AREAS OF WORK:

The requirements in this Section (B) apply to this contract where indicated by a blackened box (■).

The Special Experience Requirements set forth below apply to the Entity that will perform the specific area of work. **Compliance with such Special Experience Requirements will be determined solely by the City after an award of contract. Within two (2) weeks of award of contract, the contractor will be required to submit the qualifications of the Entity that will perform the specific area of work.** If the bidder intends to perform such work itself, it must demonstrate compliance with the Special Experience Requirements. If the bidder intends to subcontract this work, the proposed subcontractor or sub-subcontractor must demonstrate compliance with the Special Experience Requirements. Once approved, no substitution will be permitted, unless the qualifications of the proposed replacement have been approved in writing in advance by the City.

Special Experience Requirements apply to the Entity that will perform any specific area of work indicated by a blackened box. The Entity may have performed the required prior project(s) as a prime contractor, subcontractor or sub-subcontractor.

Hazmat Work: Hazmat Work is any item of work in the Bid Schedule that begins with the prefix 8.01. The Entity that will perform any Hazmat Work must, within the last three (3) consecutive years prior to the bid opening, have successfully completed in a timely fashion at least five (5) projects similar in scope and type to the required work.

Pile, CFA Pile, and/or Mini-Pile Work: The Entity that will perform the Pile, CFA Pile and/or Mini-Pile Work must, within the last three (3) consecutive years prior to the bid opening, have successfully completed in a timely fashion at least two (2) projects similar in scope and type to the required work.

For professional services in connection with Pile Work (i.e., engineering and inspection services), the individual who will perform the required services must be a Professional Engineer licensed by the state of New York. Such individual must also comply with the above requirements for prior projects.

Construction Report, Monitoring and Post-Construction Report, and Continuous Real-Time Monitoring For Vibrations and Movements and Post-Construction Report Work: The Entity that will perform the Construction Report, Monitoring For Vibrations And Movements, and Post-Construction Report Work must, within the last three (3) consecutive years prior to the bid opening, have successfully completed in a timely fashion at least two (2) projects similar in scope and type to the required work.

For professional services in connection with Reporting and Monitoring Work (i.e., engineering and inspection services), the individual who will perform the required services must be a Professional Engineer licensed by the state of New York. Such individual must also comply with the above requirements for prior projects.

OTHER: _____

(C) **SPECIFICATIONS:** In the event of any conflict, omission or inconsistency between (1) the Specifications and/or Contract Drawings, and (2) the Special Experience Requirements in Section (B) of the Special Notice to Bidders, the special experience listed in the Specifications and/or Contract Drawings shall be controlling. The Special Experience Requirements in Section (B) of this Special Notice to Bidders are only for the convenience of the bidders.

(D) **SUBMISSION REQUIREMENTS:** For each project submitted to demonstrate compliance with the Special Experience Requirements, the bidder must complete and submit the Qualification Form included in the Bid Booklet. The City will only evaluate a project if the following criteria are met: (1) the project is described on the Qualification Form, and (2) all information on the Qualification Form is provided. The City will not evaluate any project which does not comply with the criteria set forth herein, including any project which is referred to only on the resume of an individual.

If Special Experience Requirements are indicated for any specific area of work, the submission requirement set forth above shall apply to the entity that will perform the specific area of work.

(E) **CONDITIONS:** In determining compliance with the Special Experience Requirements for the bidder set forth above, the City may consider prior projects completed by principal(s) or other employees of the bidder while affiliated with another entity, subject to the conditions set forth below.

- Any principal or other employee on whose prior experience the bidder is relying to demonstrate compliance with this special experience requirement must have held the following: (a) a significant management role in the prior entity with which the principal or other employee was affiliated, and (b) a significant management role in the entity submitting the bid for a period of at least six (6) months, or from the inception of the bidding entity.
- The bidder may not rely on the experience of its principals or other employees to demonstrate compliance with any other requirements, including without limitation, financial requirements or requirements for a specified minimum amount of annual gross revenues.

(F) **JOINT VENTURES:** In the event the bidder is a joint venture, at least one firm in the joint venture must meet the above described experience requirements.

M/WBE PROGRAM: M/WBE UTILIZATION PLAN

M/WBE Program Requirements: The requirements for the M/WBE Program are set forth on the following pages of this Bid Booklet, in the section entitled "Notice to All Prospective Contractors."

Schedule B: M/WBE Utilization Plan: The M/WBE Utilization Plan for this Contract is set forth in this Bid Booklet starting on page A-37. The M/WBE Utilization Plan (Part I) indicates whether Participation Goals have been established for this Contract. If Participation Goals have been established for this Contract, the bidder must submit an M/WBE Utilization Plan (Part II) with its bid.

Waiver: The bidder may seek a full or partial pre-award waiver of the Participation Goals in accordance with the "Notice to All Prospective Contractors" (See Part A, Section 10). The bidder's request for a waiver must be submitted at least seven (7) calendar days prior to the bid date. Waiver requests submitted after the deadline will not be considered. The form for requesting a waiver of the Participation Goals is set forth in the M/WBE Utilization Plan (Part III).

Rejection of the Bid: The bidder must complete Schedule B: M/WBE Utilization Plan (Part II) set forth in this Bid Booklet starting on page A-39.

The bidder's submission of Schedule B must include both the Vendor Certification and Required Affirmations (see Section V of Part II). If the bidder does not provide a complete Schedule B submission at the time of bid, the Agency will deem the bid to be non-responsive, unless a full waiver of the Participation Goals is granted (Schedule B, Part III). In the event that the City determines that the bidder has submitted a Schedule B where the Vendor Certification and Required Affirmations are completed but other aspects of the Schedule B are not complete, or contain a copy or computation error that is at odds with the Vendor Certification and Required Affirmations, the bidder will be notified by the Agency and will be given four (4) calendar days from receipt of notification to cure the specified deficiencies and return a completed Schedule B to the Agency. Failure to do so will result in a determination that the Bid is non-responsive. Receipt of notification is defined as the date notice is emailed or faxed (if the bidder has provided an email address or fax number), or no later than five (5) calendar days from the date of mailing or upon delivery, if delivered.

Impact on LBE Requirements: If Participation Goals have been established for the participation of M/WBEs, the contractor is not required to comply with the Locally Based Enterprise Program ("LBE"). The LBE Program's requirements are set forth in Article 67 of the Contract.

NOTICE TO ALL PROSPECTIVE CONTRACTORS

PARTICIPATION BY MINORITY-OWNED AND WOMEN-OWNED BUSINESS ENTERPRISES IN CITY PROCUREMENT

ARTICLE I. M/WBE PROGRAM

Local Law No. 129 of 2005 added and Local Law 1 of 2013 amended Section 6-129 of the Administrative Code of the City of New York (hereinafter "Section 6-129"). Section 6-129 establishes the program for participation in City procurement ("M/WBE Program") by minority-owned business enterprises ("MBEs") and women-owned business enterprises ("WBEs"), certified in accordance with Section 1304 of the New York City Charter. As stated in Section 6-129, the intent of the program is to address the impact of discrimination on the City's procurement process, and to promote the public interest in avoiding fraud and favoritism in the procurement process, increasing competition for City business, and lowering contract costs. The contract provisions contained herein are pursuant to Section 6-129, and the rules of the Department of Small Business Services ("DSBS") promulgated thereunder.

If this Contract is subject to the M/WBE Program established by Section 6-129, the specific requirements of MBE and/or WBE participation for this Contract are set forth in Schedule B of the Contract (entitled the "M/WBE Utilization Plan"), and are detailed below. The Contractor must comply with all applicable MBE and WBE requirements for this Contract.

All provisions of Section 6-129 are hereby incorporated in the Contract by reference and all terms used herein that are not defined herein shall have the meanings given such terms in Section 6-129. Article I, Part A, below, sets forth provisions related to the participation goals for construction, standard and professional services contracts. Article I, Part B, below, sets forth miscellaneous provisions related to the M/WBE Program.

PART A

PARTICIPATION GOALS FOR CONSTRUCTION, STANDARD AND PROFESSIONAL SERVICES CONTRACTS OR TASK ORDERS

1. The **MBE and/or WBE Participation Goals** established for this Contract or Task Orders issued pursuant to this Contract, ("**Participation Goals**"), as applicable, are set forth on Schedule B, Part I to this Contract (see Page 1, line 1 Total Participation Goals) or will be set forth on Schedule B, Part I to Task Orders issued pursuant to this Contract, as applicable.

The **Participation Goals** represent a percentage of the total dollar value of the Contract or Task Order, as applicable, that may be achieved by awarding subcontracts to firms certified with New York City Department of Small Business Services as MBEs and/or WBEs, and/or by crediting the participation of prime contractors and/or qualified joint ventures as provided in Section 3 below, unless the goals have been waived or modified by Agency in accordance with Section 6-129 and Part A, Sections 10 and 11 below, respectively.

2. If **Participation Goals** have been established for this Contract or Task Orders issued pursuant to this Contract, Contractor agrees or shall agree as a material term of the Contract that Contractor shall be subject to the **Participation Goals**, unless the goals are waived or modified by Agency in accordance with Section 6-129 and Part A, Sections 10 and 11 below, respectively.

3. If **Participation Goals** have been established for this Contract or Task Order issued pursuant to this Contract, a Contractor that is an MBE and/or WBE shall be permitted to count its own participation toward fulfillment of the relevant **Participation Goal**, provided that in accordance with Section 6-129 the value of Contractor's participation shall be determined by subtracting from the total value of the Contract or Task Order, as applicable, any amounts that the Contractor pays to direct subcontractors (as defined in Section 6-129(c)(13)), and provided

further that a Contractor that is certified as both an MBE and a WBE may count its own participation either toward the goal for MBEs or the goal for WBEs, but not both.

A Contractor that is a qualified joint venture (as defined in Section 6-129(c)(30)) shall be permitted to count a percentage of its own participation toward fulfillment of the relevant **Participation Goal**. In accordance with Section 6-129, the value of Contractor's participation shall be determined by subtracting from the total value of the Contract or Task Order, as applicable, any amounts that Contractor pays to direct subcontractors, and then multiplying the remainder by the percentage to be applied to total profit to determine the amount to which an MBE or WBE is entitled pursuant to the joint venture agreement, provided that where a participant in a joint venture is certified as both an MBE and a WBE, such amount shall be counted either toward the goal for MBEs or the goal for WBEs, but not both.

4. A. If **Participation Goals** have been established for this Contract, a prospective contractor shall be required to submit with its bid or proposal, as applicable, a completed Schedule B, MWBE Utilization Plan, Part II (see Pages 2-4) indicating: (a) whether the contractor is an MBE or WBE, or qualified joint venture; (b) the percentage of work it intends to award to direct subcontractors; and (c) in cases where the contractor intends to award direct subcontracts, a description of the type and dollar value of work designated for participation by MBEs and/or WBEs, and the time frames in which such work is scheduled to begin and end. In the event that this MWBE Utilization Plan indicates that the bidder or proposer, as applicable, does not intend to meet the **Participation Goals**, the bid or proposal, as applicable, shall be deemed non-responsive, unless Agency has granted the bidder or proposer, as applicable, a pre-award waiver of the Participation Goals in accordance with Section 6-129 and Part A, Section 10 below.

B. (i) If this Contract is for a master services agreement or other requirements type contract that will result in the issuance of Task Orders that will be individually registered ("Master Services Agreement") and is subject to MWBE **Participation Goals**, a prospective contractor shall be required to submit with its bid or proposal, as applicable, a completed Schedule B, MWBE Participation Requirements for Master Services Agreements That Will Require Individually Registered Task Orders, Part II (page 2) indicating the prospective contractor's certification and required affirmations to make all reasonable good faith efforts to meet participation goals established on each individual Task Order issued pursuant to this Contract, or if a partial waiver is obtained or such goals are modified by the Agency, to meet the modified **Participation Goals** by soliciting and obtaining the participation of certified MBE and/or WBE firms. In the event that the Schedule B indicates that the bidder or proposer, as applicable, does not intend to meet the **Participation Goals** that may be established on Task Orders issued pursuant to this Contract, the bid or proposal, as applicable, shall be deemed nonresponsive.

(ii) **Participation Goals** on a Master Services Agreement will be established for individual Task Orders issued after the Master Services Agreement is awarded. If **Participation Goals** have been established on a Task Order, a contractor shall be required to submit a Schedule B – MWBE Utilization Plan For Independently Registered Task Orders That Are Issued Pursuant to Master Services Agreements, Part II (see Pages 2-4) indicating: (a) whether the contractor is an MBE or WBE, or qualified joint venture; (b) the percentage of work it intends to award to direct subcontractors; and (c) in cases where the contractor intends to award direct subcontracts, a description of the type and dollar value of work designated for participation by MBEs and/or WBEs, and the time frames in which such work is scheduled to begin and end. The contractor must engage in good faith efforts to meet the **Participation Goals** as established for the Task Order unless Agency has granted the contractor a pre-award waiver of the Participation Goals in accordance with Section 6-129 and Part A, Section 10 below.

C. **THE BIDDER/PROPOSER MUST COMPLETE THE SCHEDULE B INCLUDED HEREIN (SCHEDULE B, PART II). A SCHEDULE B SUBMITTED BY THE BIDDER/PROPOSER WHICH DOES NOT INCLUDE THE VENDOR CERTIFICATION AND REQUIRED AFFIRMATIONS (SEE SECTION V OF PART II) WILL BE DEEMED TO BE NON-**

RESPONSIVE, UNLESS A FULL WAIVER OF THE PARTICIPATION GOALS IS GRANTED (SCHEDULE B, PART III). IN THE EVENT THAT THE CITY DETERMINES THAT THE BIDDER/PROPOSER HAS SUBMITTED A SCHEDULE B WHERE THE VENDOR CERTIFICATION AND REQUIRED AFFIRMATIONS ARE COMPLETED BUT OTHER ASPECTS OF THE SCHEDULE B ARE NOT COMPLETE, OR CONTAIN A COPY OR COMPUTATION ERROR THAT IS AT ODDS WITH THE VENDOR CERTIFICATION AND AFFIRMATIONS, THE BIDDER/PROPOSER WILL BE NOTIFIED BY THE AGENCY AND WILL BE GIVEN FOUR (4) CALENDAR DAYS FROM RECEIPT OF NOTIFICATION TO CURE THE SPECIFIED DEFICIENCIES AND RETURN A COMPLETED SCHEDULE B TO THE AGENCY. FAILURE TO DO SO WILL RESULT IN A DETERMINATION THAT THE BID/PROPOSAL IS NON-RESPONSIVE. RECEIPT OF NOTIFICATION IS DEFINED AS THE DATE NOTICE IS E-MAILED OR FAXED (IF THE BIDDER/PROPOSER HAS PROVIDED AN E-MAIL ADDRESS OR FAX NUMBER), OR NO LATER THAN FIVE (5) CALENDAR DAYS FROM THE DATE OF MAILING OR UPON DELIVERY, IF DELIVERED.

5. Where an **M/WBE** Utilization Plan has been submitted, the Contractor shall, within 30 days of issuance by Agency of a notice to proceed, submit a list of proposed persons or entities to which it intends to award subcontracts within the subsequent 12 months. In the case of multiyear contracts, such list shall also be submitted every year thereafter. The Agency may also require the Contractor to report periodically about the contracts awarded by its direct subcontractors to indirect subcontractors (as defined in Section 6-129(c)(22)). **PLEASE NOTE: If this Contract is a public works project subject to GML §101(5) (i.e., a contract valued at or below \$3M for projects in New York City) or if the Contract is subject to a project labor agreement in accordance with Labor Law §222, and the bidder is required to identify at the time of bid submission its intended subcontractors for the Wicks trades (plumbing and gas fitting; steam heating, hot water heating, ventilating and air conditioning (HVAC); and electric wiring), the Contractor must identify all those to which it intends to award construction subcontracts for any portion of the Wicks trade work at the time of bid submission, regardless of what point in the life of the contract such subcontracts will occur. In identifying intended subcontractors in the bid submission, bidders may satisfy any Participation Goals established for this Contract by proposing one or more subcontractors that are MBEs and/or WBEs for any portion of the Wicks trade work. In the event that the Contractor's selection of a subcontractor is disapproved, the Contractor shall have a reasonable time to propose alternate subcontractors.**

6. MBE and WBE firms must be certified by DSBS in order for the Contractor to credit such firms' participation toward the attainment of the **Participation Goals**. Such certification must occur prior to the firms' commencement of work. A list of MBE and WBE firms may be obtained from the DSBS website at www.nyc.gov/buycertified, by emailing DSBS at buyer@sbs.nyc.gov, by calling (212) 513-6356, or by visiting or writing DSBS at 110 William St., New York, New York, 10038, 7th floor. Eligible firms that have not yet been certified may contact DSBS in order to seek certification by visiting www.nyc.gov/getcertified, emailing MWBE@sbs.nyc.gov, or calling the DSBS certification helpline at (212) 513-6311. A firm that is certified as both an MBE and a WBE may be counted either toward the goal for MBEs or the goal for WBEs, but not both. No credit shall be given for participation by a graduate MBE or graduate WBE, as defined in Section 6-129(c)(20).

7. Where an **M/WBE** Utilization Plan has been submitted, the Contractor shall, with each voucher for payment, and/or periodically as Agency may require, submit statements, certified under penalty of perjury, which shall include, but not be limited to, the total amount the Contractor paid to its direct subcontractors, and, where applicable pursuant to Section 6-129(j), the total amount direct subcontractors paid to indirect subcontractors; the names, addresses and contact numbers of each MBE or WBE hired as a subcontractor by the Contractor, and, where applicable, hired by any of the Contractor's direct subcontractors; and the dates and amounts paid to each MBE or WBE. The Contractor shall also submit, along with its voucher for final payment: the total

amount it paid to subcontractors, and, where applicable pursuant to Section 6-129(j), the total amount its direct subcontractors paid directly to their indirect subcontractors; and a final list, certified under penalty of perjury, which shall include the name, address and contact information of each subcontractor that is an MBE or WBE, the work performed by, and the dates and amounts paid to each.

8. If payments made to, or work performed by, MBEs or WBEs are less than the amount specified in the Contractor's **M/WBE Utilization Plan**, Agency shall take appropriate action, in accordance with Section 6-129 and Article II below, unless the Contractor has obtained a modification of its **M/WBE Utilization Plan** in accordance with Section 6-129 and Part A, Section 11 below.

9. Where an **M/WBE Utilization Plan** has been submitted, and the Contractor requests a change order the value of which exceeds the greater of 10 percent of the Contract or Task Order, as applicable, or \$500,000, Agency shall review the scope of work for the Contract or Task Order, as applicable, and the scale and types of work involved in the change order, and determine whether the **Participation Goals** should be modified.

10. **Pre-award waiver of the Participation Goals.** (a) A bidder or proposer, or contractor with respect to a Task Order, may seek a pre-award full or partial waiver of the **Participation Goals** in accordance with Section 6-129, which requests that Agency change one or more **Participation Goals** on the grounds that the **Participation Goals** are unreasonable in light of the availability of certified firms to perform the services required, or by demonstrating that it has legitimate business reasons for proposing a lower level of subcontracting in its **M/WBE Utilization Plan**.

(b) To apply for a full or partial waiver of the **Participation Goals**, a bidder, proposer, or contractor, as applicable, must complete Part III (Page 5) of Schedule B and submit such request no later than seven (7) calendar days prior to the date and time the bids, proposals, or Task Orders are due, in writing to the Agency by email at zhangji@ddc.nyc.gov or via facsimile at (718) 391-1886. Bidders, proposers, or contractors, as applicable, who have submitted requests will receive an Agency response by no later than two (2) calendar days prior to the due date for bids, proposals, or Task Orders; provided, however, that if that date would fall on a weekend or holiday, an Agency response will be provided by close-of-business on the business day before such weekend or holiday date.

(c) If the Agency determines that the **Participation Goals** are unreasonable in light of the availability of certified firms to perform the services required, it shall revise the solicitation and extend the deadline for bids and proposals, or revise the Task Order, as applicable.

(d) Agency may grant a full or partial waiver of the **Participation Goals** to a bidder, proposer or contractor, as applicable, who demonstrates—before submission of the bid, proposal or Task Order, as applicable—that it has legitimate business reasons for proposing the level of subcontracting in its **M/WBE Utilization Plan**. In making its determination, Agency shall consider factors that shall include, but not be limited to, whether the bidder, proposer or contractor, as applicable, has the capacity and the bona fide intention to perform the Contract without any subcontracting, or to perform the Contract without awarding the amount of subcontracts represented by the **Participation Goals**. In making such determination, Agency may consider whether the **M/WBE Utilization Plan** is consistent with past subcontracting practices of the bidder, proposer or contractor, as applicable, whether the bidder, proposer or contractor, as applicable, has made efforts to form a joint venture with a certified firm, and whether the bidder, proposer, or contractor, as applicable, has made good faith efforts to identify other portions of the Contract that it intends to subcontract.

11. **Modification of M/WBE Utilization Plan.** (a) A Contractor may request a modification of its **M/WBE Utilization Plan** after award of this Contract. **PLEASE NOTE: If this Contract is a public works project subject to GML §101(5) (i.e., a contract valued at or below \$3M for projects in New York City) or if the Contract is subject to a project labor agreement in accordance**

with Labor Law §222, and the bidder is required to identify at the time of bid submission its intended subcontractors for the Wicks trades (plumbing and gas fitting; steam heating, hot water heating, ventilating and air conditioning (HVAC); and electric wiring), the Contractor may request a Modification of its M/WBE Utilization Plan as part of its bid submission. The Agency may grant a request for Modification of a Contractor's M/WBE Utilization Plan if it determines that the Contractor has established, with appropriate documentary and other evidence, that it made reasonable, good faith efforts to meet the **Participation Goals**. In making such determination, Agency shall consider evidence of the following efforts, as applicable, along with any other relevant factors:

- (i) The Contractor advertised opportunities to participate in the Contract, where appropriate, in general circulation media, trade and professional association publications and small business media, and publications of minority and women's business organizations;
- (ii) The Contractor provided notice of specific opportunities to participate in the Contract, in a timely manner, to minority and women's business organizations;
- (iii) The Contractor sent written notices, by certified mail or facsimile, in a timely manner, to advise MBEs or WBEs that their interest in the Contract was solicited;
- (iv) The Contractor made efforts to identify portions of the work that could be substituted for portions originally designated for participation by MBEs and/or WBEs in the M/WBE Utilization Plan, and for which the Contractor claims an inability to retain MBEs or WBEs;
- (v) The Contractor held meetings with MBEs and/or WBEs prior to the date their bids or proposals were due, for the purpose of explaining in detail the scope and requirements of the work for which their bids or proposals were solicited;
- (vi) The Contractor made efforts to negotiate with MBEs and/or WBEs as relevant to perform specific subcontracts, or act as suppliers or service providers;
- (vii) Timely written requests for assistance made by the Contractor to Agency's M/WBE liaison officer and to DSBS;
- (viii) Description of how recommendations made by DSBS and Agency were acted upon and an explanation of why action upon such recommendations did not lead to the desired level of participation of MBEs and/or WBEs.

Agency's M/WBE officer shall provide written notice to the Contractor of the determination.

(b) The Agency may modify the **Participation Goals** when the scope of the work has been changed by the Agency in a manner that affects the scale and types of work that the Contractor indicated in its M/WBE Utilization Plan would be awarded to subcontractors.

12. If this Contract is for an indefinite quantity of construction, standard or professional services or is a requirements type contract and the Contractor has submitted an M/WBE Utilization Plan and has committed to subcontract work to MBEs and/or WBEs in order to meet the **Participation Goals**, the Contractor will not be deemed in violation of the M/WBE Program requirements for this Contract with regard to any work which was intended to be subcontracted to an MBE and/or WBE to the extent that the Agency has determined that such work is not needed.

13. If **Participation Goals** have been established for this Contract or a Task Order issued pursuant to this Contract, at least once annually during the term of the Contract or Task Order, as applicable, Agency shall review the Contractor's progress toward attainment of its M/WBE Utilization Plan, including but not limited to, by reviewing the percentage of work the Contractor has actually awarded to MBE and/or WBE subcontractors and the payments the Contractor made to such subcontractors.

14. If **Participation Goals** have been established for this Contract or a Task Order issued pursuant to this Contract, Agency shall evaluate and assess the Contractor's performance in meeting those goals, and such evaluation and assessment shall become part of the Contractor's overall contract performance evaluation.

PART B: MISCELLANEOUS

1. The Contractor shall take notice that, if this solicitation requires the establishment of an **M/WBE Utilization Plan**, the resulting contract may be audited by DSBS to determine compliance with Section 6-129. See §6-129(e)(10). Furthermore, such resulting contract may also be examined by the City's Comptroller to assess compliance with the **M/WBE Utilization Plan**.
2. Pursuant to DSBS rules, construction contracts that include a requirement for an **M/WBE Utilization Plan** shall not be subject to the law governing Locally Based Enterprises set forth in Section 6-108.1 of the Administrative Code of the City of New York.
3. DSBS is available to assist contractors and potential contractors in determining the availability of MBEs and/or WBEs to participate as subcontractors, and in identifying opportunities that are appropriate for participation by MBEs and/or WBEs in contracts.
4. Prospective contractors are encouraged to enter into qualified joint venture agreements with MBEs and/or WBEs as defined by Section 6-129(c)(30).
5. By submitting a bid or proposal the Contractor hereby acknowledges its understanding of the **M/WBE Program** requirements set forth herein and the pertinent provisions of Section 6-129, and any rules promulgated thereunder, and if awarded this Contract, the Contractor hereby agrees to comply with the **M/WBE Program** requirements of this Contract and pertinent provisions of Section 6-129, and any rules promulgated thereunder, all of which shall be deemed to be material terms of this Contract. The Contractor hereby agrees to make all reasonable, good faith efforts to solicit and obtain the participation of MBEs and/or WBEs to meet the required **Participation Goals**.

ARTICLE II. ENFORCEMENT

1. If Agency determines that a bidder or proposer, as applicable, has, in relation to this procurement, violated Section 6-129 or the DSBS rules promulgated pursuant to Section 6-129, Agency may disqualify such bidder or proposer, as applicable, from competing for this Contract and the Agency may revoke such bidder's or proposer's prequalification status, if applicable.
2. Whenever Agency believes that the Contractor or a subcontractor is not in compliance with Section 6-129 or the DSBS rules promulgated pursuant to Section 6-129, or any provision of this Contract that implements Section 6-129, including, but not limited to any **M/WBE Utilization Plan**, Agency shall send a written notice to the Contractor describing the alleged noncompliance and offering the Contractor an opportunity to be heard. Agency shall then conduct an investigation to determine whether such Contractor or subcontractor is in compliance.
3. In the event that the Contractor has been found to have violated Section 6-129, the DSBS rules promulgated pursuant to Section 6-129, or any provision of this Contract that implements Section 6-129, including, but not limited to, any **M/WBE Utilization Plan**, Agency may determine that one of the following actions should be taken:
 - (a) entering into an agreement with the Contractor allowing the Contractor to cure the violation;
 - (b) revoking the Contractor's pre-qualification to bid or make proposals for future contracts;
 - (c) making a finding that the Contractor is in default of the Contract;
 - (d) terminating the Contract;
 - (e) declaring the Contractor to be in breach of Contract;
 - (f) withholding payment or reimbursement;
 - (g) determining not to renew the Contract;
 - (h) assessing actual and consequential damages;
 - (i) assessing liquidated damages or reducing fees, provided that liquidated damages may be based on amounts representing costs of delays in carrying out the purposes of the **M/WBE Program**, or in meeting the purposes of the Contract, the costs of meeting utilization goals

through additional procurements, the administrative costs of investigation and enforcement, or other factors set forth in the Contract;

- (j) exercising rights under the Contract to procure goods, services or construction from another contractor and charge the cost of such contract to the Contractor that has been found to be in noncompliance; or
- (k) taking any other appropriate remedy.

4. If an **M/WBE** Utilization Plan has been submitted, and pursuant to this Article II, Section 3, the Contractor has been found to have failed to fulfill its **Participation Goals** contained in its **M/WBE** Utilization Plan or the **Participation Goals** as modified by Agency pursuant to Article I, Part A, Section 11, Agency may assess liquidated damages in the amount of ten percent (10%) of the difference between the dollar amount of work required to be awarded to MBE and/or WBE firms to meet the **Participation Goals** and the dollar amount the Contractor actually awarded and paid, and/or credited, to MBE and/or WBE firms. In view of the difficulty of accurately ascertaining the loss which the City will suffer by reason of Contractor's failure to meet the **Participation Goals**, the foregoing amount is hereby fixed and agreed as the liquidated damages that the City will suffer by reason of such failure, and not as a penalty. Agency may deduct and retain out of any monies which may become due under this Contract the amount of any such liquidated damages; and in case the amount which may become due under this Contract shall be less than the amount of liquidated damages suffered by the City, the Contractor shall be liable to pay the difference.

5. Whenever Agency has reason to believe that an MBE and/or WBE is not qualified for certification, or is participating in a contract in a manner that does not serve a commercially useful function (as defined in Section 6-129(c)(8)), or has violated any provision of Section 6-129, Agency shall notify the Commissioner of DSBS who shall determine whether the certification of such business enterprise should be revoked.

6. Statements made in any instrument submitted to Agency pursuant to Section 6-129 shall be submitted under penalty of perjury and any false or misleading statement or omission shall be grounds for the application of any applicable criminal and/or civil penalties for perjury. The making of a false or fraudulent statement by an MBE and/or WBE in any instrument submitted pursuant to Section 6-129 shall, in addition, be grounds for revocation of its certification.

7. The Contractor's record in implementing its **M/WBE** Utilization Plan shall be a factor in the evaluation of its performance. Whenever Agency determines that a Contractor's compliance with an **M/WBE** Utilization Plan has been unsatisfactory, Agency shall, after consultation with the City Chief Procurement Officer, file an advice of caution form for inclusion in PASSPort as caution data.

PRE-AWARD PROCESS

The bidder is advised that as part of the pre-award review of its bid, the Agency will require the three lowest apparent responsive and responsible bidders to submit the information described in Sections (A) through (D) below. These bidders will be notified by DDC (by email, facsimile, or in writing), and the Agency's notice will specify the types of information that the bidder must submit to the Agency. The types of information the bidder may be required to submit are described below. Once notified, the bidder must submit such information to the Agency within five (5) business days following receipt of notification from DDC that it is among the low bidders. In the event the bidder fails to submit the required information within the specified time frame, the Agency may reject the bid as being non-responsive.

In the event the bidder fails to submit the required information within the specified time frame, the Agency may reject the bid as being nonresponsive.

- (A) **Project Reference Form:** The bidder must complete and submit the Project Reference Form set forth starting on page A-47 of this Bid Booklet. The Project Reference Form consists of three (3) parts: (1) Contracts Completed by the Bidder, (2) Contracts Currently Under Construction by the Bidder, and (3) Pending Contracts Not Yet Started by the Bidder.
- (B) **Copy of License:** The bidder must submit a copy of the license under which the bidder will be performing the work. Such license must clearly show the following: (1) Name of the Licensee, (2) License Number, and (3) Expiration date of the License. A copy of the license will be required from bidders for the following contracts: Plumbing Work, Electrical Work and Asbestos Abatement.
- (C) **Financial Information:** The bidder must submit the financial information described below:
- (1) **Audited Financial Statements:** Financial statements (Balance Sheet and Income Statement) of the entity submitting the bid, as audited by an independent auditor licensed to practice as a certified public accountant (CPA). Audited financial statements for the three (3) most recent fiscal years must be submitted. Each such financial statement must include the auditor's standard report.
- If the bidder does not have audited financial statements, the bidder must submit an affidavit attesting to the fact that the bidder does not have such statements. In addition, the bidder must submit the following documentation covering the three (3) most recent fiscal years: signed federal tax returns, unaudited financial statements, and a "certified review letter" from a certified public accountant (CPA) verifying the unaudited financial statements.
- Unless the most recent audited or unaudited financial statement was issued within ninety (90) days, the bidder must submit interim financial information that includes data on financial position and results of operation (income data) for the current fiscal year. Such information may be summarized on a monthly or quarterly basis or at other intervals.
- (2) **Schedule of Aged Accounts Receivable,** including portion due within ninety (90) days.
- (D) **Project Specific Information:** The bidder must submit the project specific information described below:
- (1) **Statement** indicating the number of years of experience the bidder has had and in what type of construction.
- (2) **Resumes** of all key personnel to be involved in the project, including the proposed project superintendent.

- (3) List of significant pieces of equipment expected to be used for the contract, and whether such equipment is owned or leased.
- (4) Description of work expected to be subcontracted, and to what firms, if known.
- (5) List of key material suppliers.
- (6) Preliminary bar chart time schedule
- (7) The bidder's expected means of financing the project. This submission should be based on the assumption that the contractor is required to finance two times (2X) the average monthly billings for the project throughout the contract period.
- (8) Any other issues the bidder sees as impacting the contractor's ability to complete the project according to the contract.

In addition to the information described in Sections (A) through (D) above, the bidder shall submit such additional information as the Commissioner may require, including without limitation, an explanation or justification for specific unit price items.

The bidder is further advised that it may be required to attend a pre-award meeting with DDC representatives. If such a meeting is convened, the bidder will be advised as to any additional material to be provided.

PASSPort COMPLIANCE

All vendors that intend to do business with the City of New York must complete a disclosure process in order to be considered for a contract. This disclosure process was formerly completed using Vendor Information Exchange System (VENDEX) paper-based forms. The City of New York has moved collection of vendor disclosure information online. In early August 2017, the New York City Mayor's Office of Contract Services (MOCS) launched the **Procurement and Sourcing Solutions Portal (PASSPort)**, a new online procurement system that replaced the paper-VENDEX process. In anticipation of awards, all bidders must create online accounts in the new PASSPort system, and file all disclosure information using PASSPort. **Paper submissions, including certifications of no changes to existing VENDEX packages, will not be accepted in lieu of complete online filings using PASSPort.**

All vendors that intend to do business with the City, but specifically those that fall into any of the following categories, are required to enroll:

- Have a pending award with a City Agency; or
- Hold a current contract with a City Agency and have either an expiring VENDEX or expiring Certificate of No Change.

The Department of Design and Construction (DDC) and MOCS hereby notifies all proposers that the PASSPort system is available, and that disclosure filing completion is required prior to any award through this competitive bid.

To enroll in PASSPort and to access the PASSPort website (including online training), please visit www.nyc.gov/passport. Contact MOCS at passport@mocs.nyc.gov for additional information and technical support.

CONSTRUCTION EMPLOYMENT REPORT

All bidders will be required to submit either a Construction Employment Report (CER) if the bid amount is \$1,000,000 or greater.

The CER template form is available online at:

https://www1.nyc.gov/assets/sbs/downloads/pdf/businesses/DLS_Constru_Employ_Rpt.pdf

Instructions for completing the Construction Employment Report are available online at:

https://www1.nyc.gov/assets/sbs/downloads/pdf/businesses/DLS_Cons_Employ_Rpt_Inst.pdf

**CITY OF NEW YORK
DEPARTMENT OF DESIGN AND CONSTRUCTION
DIVISION OF INFRASTRUCTURE**

REQUIRED FORMS

(NO TEXT ON THIS PAGE)

BID FORM

THE CITY OF NEW YORK
DEPARTMENT OF DESIGN AND CONSTRUCTION
DIVISION OF INFRASTRUCTURE

BID FOR FURNISHING ALL LABOR AND
MATERIAL NECESSARY AND REQUIRED FOR:

PROJECT ID: SEQBN11
RECONSTRUCTION OF EXISTING SEWERS, NORTH QUEENS

Together With All Work Incidental Thereto
BOROUGH OF QUEENS
CITY OF NEW YORK

Name of Bidder: ADC CONSTRUCTION, LLC

Date of Bid Opening: DECEMBER 5, 2019

Bidder is: (Check one, whichever applies) Individual () Partnership () Corporation ()

Place of Business of Bidder: 58-08 48TH ST MASPETH NY 11378

Bidder's Telephone Number: 718 628 5555 Fax Number: 718 628 5142

Bidder's E-Mail Address: ADC.CONSTRUCTION@VERIZON.NET

Residence of Bidder (If Individual): _____

If Bidder is a Partnership, fill in the following blanks:

Names of Partners

Residence of Partners

If Bidder is a Corporation, ^{LLC} fill in the following blanks:

Organized under the laws of the State of NEW YORK

Name and Home Address of President: DOMENICK CIPOLLONE
HASTINGS NY

Name and Home Address of Secretary: ANTHONY CIPOLLONE
PURCHASE NY

Name and Home Address of Treasurer: _____

BID FORM

The above-named Bidder affirms and declares:

1. The said bidder is of lawful age and the only one interested in this bid; and no person, firm or corporation other than hereinbefore named has any interest in this bid, or in the Contract proposed to be taken.
2. By submission of this bid, each bidder and each person signing on behalf of any bidder certifies, and in the case of a joint bid each party thereto certifies as to its own organization, under penalty of perjury, that to the best of its knowledge and belief: (1) the prices in this bid have been arrived at independently without collusion, consultation, communication or agreement, for the purpose of restricting competition, as to any matter relating to such prices with any other bidder or with any competitor; (2) unless otherwise required by law, the prices quoted in this bid have not been knowingly disclosed by the bidder and will not knowingly be disclosed by the bidder prior to opening, directly or indirectly, to any other bidder or to any competitor; and (3) No attempt has been made or will be made by the bidder to induce any other person, partnership or corporation to submit or not to submit a bid for the purpose of restricting competition.
3. No councilman or other officer or employee or person whose salary is payable in whole or in part from the City Treasury is directly or indirectly interested in this bid, or in the supplies, materials, equipment, work or labor to which it relates, or in any of the profits thereof.
4. The bidder is not in arrears to the City of New York upon debt or contract or taxes, and is not a defaulter, as surety or otherwise, upon any obligation of the City of New York, and has not been declared not responsible, or disqualified, by any agency of the City of New York or State of New York, nor is there any proceeding pending relating to the responsibility or qualification of the bidder to receive public contracts except as set forth on the Affirmation included as page C-6 of this Bid Booklet.

The bidder hereby affirms that it has paid all applicable City income, excise and other taxes for all years it has conducted business activities in New York City.

5. The bidder, as an individual, or as a member, partner, director or officer of the bidder, if the same be a firm, partnership or corporation, executes this document expressly warranting and representing that should this bid be accepted by the City and the Contract awarded to the bidder, the bidder and the bidder's subcontractors engaged in the performance: (1) will comply with the provisions of Section 6-108 of the Administrative Code of the City of New York and the non-discrimination provisions of Section 220a of the New York State Labor Law, as more expressly and in detail set forth in the Agreement; (2) will comply with Section 6-109 of the Administrative Code of the City of New York in relation to minimum wages and other stipulations as more expressly and in detail set forth in the Agreement; (3) have complied with the provisions of the aforesaid laws since their respective effective dates, and (4) will post notices to be furnished by the City, setting forth the requirements of the aforesaid laws in prominent and conspicuous places in each and every plant, factory, building and structure where employees engaged in the performance of the Contract can readily view it, and will continue to keep such notices posted until the supplies, materials and equipment, or work labor and services required to be furnished or rendered by the Contractor have been finally accepted by the City. In the event of any breach or violation of the foregoing, the Contractor may be subject to damages, liquidated or otherwise, cancellation of the Contract and suspension as a bidder for a period of three years. (The words, "the bidder" where used herein shall mean the individual bidder, firm, partnership or corporation executing this bid).

6. Compliance Report

The bidder, as an individual, or as a member, partner, director, or officer of the bidder, if the same be a firm, partnership, or corporation, (1) represents that the bidder's attention has been

specifically drawn to Executive Order No. 50, dated, April 25, 1980, on Equal Employment Compliance of the contract, and (2) warrants that the bidder will comply with the provisions of Executive Order No. 50. The Employment Report must be submitted as part of the bid.

The bidder, as an individual, or as a member, partner, director, or officer of the bidder, if the same be a firm, partnership, or corporation, executes this document expressly warranting that the bidder will comply with: (1) the provision of the contract on providing records, Chapter 8.

7. By submission of this bid, the bidder certifies that it now has and will continue to have the financial capability to fully perform the work required for this contract. Any award of this contract will be made in reliance upon such certification. Upon request therefor, the bidder will submit written verification of such financial capability in a form that is acceptable to the department.

8. In accordance with Section 165 of the State Finance Law, the bidder agrees that tropical hardwoods, as defined in Section 165 of the State Finance Law, shall not be utilized in the performance of this Contract, except as the same are permitted by the foregoing provision of law.

9. The bidder has visited and examined the site of the work and has carefully examined the Contract in the form approved by the Corporation Counsel, and will execute the Contract and perform all its items, covenants and conditions, and will provide, furnish and deliver all the work, materials, supplies, tools and appliances for all labor and materials necessary or required for the hereinafter named work, all in strict conformity with the Contract, for the prices set forth in the Bid Schedule.

10. **M/WBE UTILIZATION PLAN:** By signing its bid, the bidder agrees to the Vendor Certification and Required Affirmations set forth below, unless a full waiver of the Participation Goals is granted. The Vendor Certification and Required Affirmations will be deemed to satisfy the requirement to complete Section V of Part II of Schedule B: M/WBE Utilization Plan.

Section V - Vendor Certification and Required Affirmations:

I hereby:

- 1) acknowledge my understanding of the M/WBE participation requirements as set forth in this Contract and the pertinent provisions of Section 6-129 of the Administrative Code of the City of New York and the rules promulgated thereunder;
- 2) affirm that the information supplied in support of the M/WBE Utilization Plan is true and correct;
- 3) agree, if awarded this Contract, to comply with the M/WBE participation requirements of this Contract, the pertinent provisions of Section 6-129, and the rules promulgated thereunder, all of which shall be deemed to be material terms of this Contract;
- 4) agree and affirm that it is a material term of this Contract that the Vendor will award the total dollar value of the M/WBE Participation Goals to certified MBEs and/or WBEs, unless a full waiver is obtained or such goals are modified by the Agency; and
- 5) agree and affirm, if awarded this Contract, to make all reasonable, good faith efforts to meet the M/WBE Participation Goals, or if a partial waiver is obtained or such goals are modified by the Agency, to meet the modified Participation Goals by soliciting and obtaining the participation of certified MBE and/or WBE firms.

BID FORM

PROJECT ID. SEQBN11

TOTAL BID PRICE: In the space provided below, the Bidder shall indicate its Total Bid Price in figures. Such Total Bid Price is set forth on the final page of the Bid Schedule.

TOTAL BID PRICE:
(a/k/a BID PROPOSAL)

\$ 7,586,047⁷⁰

BB 12/5/17

BIDDER'S SIGNATURE AND AFFIDAVIT

Bidder: ADC CONSTRUCTION, LLC

By: *Donald C. [Signature]*
(Signature of Partner or corporate officer)

Donald C. [Signature]

Attest: Secretary of Corporate Bidder
(Corporate Seal)

Affidavit on the following page should be subscribed and sworn to before a Notary Public

BID FORM (TO BE NOTARIZED)

AFFIDAVIT WHERE BIDDER IS AN INDIVIDUAL

STATE OF NEW YORK, COUNTY OF _____ ss:
_____ being duly sworn says:
I am the person described in and who executed the foregoing bid, and the several matters therein stated are in all respects true.

(Signature of the person who signed the Bid)

Subscribed and sworn to before me this
_____ day of _____,

Notary Public

AFFIDAVIT WHERE BIDDER IS A PARTNERSHIP

STATE OF NEW YORK, COUNTY OF QUEENS ss:
DOMENICK CIPOLONE being duly sworn says:
I am a member of ADC CONSTRUCTION the firm described in and which executed the foregoing bid. I subscribed the name of the firm thereto on behalf of the firm, and the several matters therein stated are in all respects true.

Domenick Cipolone
(Signature of Partner who signed the Bid)

Subscribed and sworn to before me this
5TH day of DEC, 2019

Melissa Gallagher
Notary Public

MELISSA GALLAGHER
NOTARY PUBLIC, STATE OF NEW YORK
Registration No. 01GA6013314
Qualified in Queens County
Commission Expires 09-14-2022

AFFIDAVIT WHERE BIDDER IS A CORPORATION

STATE OF NEW YORK, COUNTY OF _____ ss:
_____ being duly sworn says:
I am the _____ of the above named corporation whose name is subscribed to and which executed the foregoing bid. I reside at _____

I have knowledge of the several matters therein stated, and they are in all respects true.

(Signature of Corporate Officer who signed the Bid)

Subscribed and sworn to before me this
_____ day of _____,

Notary Public

AFFIRMATION

PROJECT ID. SEQBN11

The undersigned bidder affirms and declares that said bidder is not in arrears to the City of New York upon debt, contract or taxes and is not a defaulter, as surety or otherwise, upon obligation to the City of New York, and has not been declared not responsible, or disqualified, by any agency of the City of New York, nor is there any proceeding pending relating to the responsibility or qualification of the bidder to receive public contracts except:

NONE

(If none, the bidder shall insert the word "None" in the space provided above.)

Full Name of Bidder: ADC CONSTRUCTION, LLC
Address: 58-08 48TH STREET
City MASPETH State NY Zip Code 11378

CHECK ONE BOX AND INCLUDE APPROPRIATE NUMBER:

A - Individual or Sole Proprietorship*
SOCIAL SECURITY NUMBER

B - Partnership, Joint Venture or other unincorporated organization ^{LLC}
EMPLOYER IDENTIFICATION NUMBER

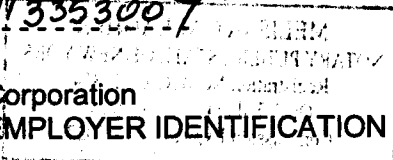
113353007

C - Corporation
EMPLOYER IDENTIFICATION NUMBER

By: 
Signature

Title: PRESIDENT

If a corporation, place seal here

This affirmation must be signed by an officer or duly authorized representative.

*Under the Federal Privacy Act the furnishing of Social Security Numbers by bidders on City contracts is voluntary. Failure to provide a Social Security Number will not result in a bidder's disqualification. Social Security Numbers will be used to identify bidders, proposers or vendors to ensure their compliance with laws, to assist the City in enforcement of laws, as well as to provide the City a means of identifying of businesses which seek City contracts.

THE UNIVERSITY OF
MICHIGAN LIBRARY
ANN ARBOR, MICHIGAN
48106-1000

BID BOND 1
FORM OF BID BOND

KNOW ALL MEN BY THESE PRESENTS. That we, ADC Construction, LLC
58-08 48th Street, Maspeth, NY 11378

hereinafter referred to as the "Principal", and Travelers Casualty and Surety Company of America
One Tower Square, Hartford, CT 06183

hereinafter referred to as the "Surety" are held and firmly bound to THE CITY OF NEW YORK,
hereinafter referred to as the "CITY", or to its successors and assigns in the penal sum of _____

TEN PERCENT OF AMOUNT BID

(10% Amt Bid), Dollars lawful money of the United States, for the payment of which said sum of money well and truly to be made, we, and each of us, bind ourselves, our heirs, executors, administrators, successors and assigns, jointly and severally, firmly by these presents.

Whereas, the Principal is about to submit (or has submitted) to the City the accompanying proposal, hereby made a part hereof, to enter into a contract in writing for _____

Contract #SEQBN11 - Reconstruction of Existing Sewers, North Queens - Borough of Queens

NOW, THEREFORE, the conditions of this obligation are such that if the Principal shall not withdraw said Proposal without the consent of the City for a period of forty-five (45) days after the opening of bids and in the event of acceptance of the Principal's Proposal by the City, if the Principal shall:

- (a) Within ten (10) days after notification by the City, execute in quadruplicate and deliver to the City all the executed counterparts of the Contract in the form set forth in the Contract Documents, in accordance with the proposal as accepted, and
- (b) Furnish a performance bond and separate payment bond, as may be required by the City, for the faithful performance and proper fulfillment of such Contract, which bonds shall be satisfactory in all respects to the City and shall be executed by good and sufficient sureties, and
- (c) In all respects perform the agreement created by the acceptance of said Proposal as provided in the Information for Bidders, bound herewith and made a part hereof, or if the City shall reject the aforesaid Proposal, then this obligation shall be null and void; otherwise to remain in full force and effect.

BID BOND 2

In the event that the Proposal of the Principal shall be accepted and the Contract be awarded to him the Surety hereunder agrees subject only to the payment by the Principal of the premium therefore, if requested by the City, to write the aforementioned performance and payment bonds in the form set forth in the Contract Documents.

It is expressly understood and agreed that the liability of the Surety for any and all claims hereunder shall in no event exceed the penal amount of this obligation as herein stated.

There shall be no liability under this bond if, in the event of the acceptance of the Principal's Proposal by the City, either a performance bond or payment bond, or both, shall not be required by the City on or before the 30th day after the date on which the City signs the Contract.

The surety, for the value received, hereby stipulates and agrees that the obligations of the Surety and its bond shall in no way be impaired or affected by any postponements of the date upon which the City will receive or open bids, or by any extensions of the time within which the City may accept the Principal's Proposal, or by any waiver by the City of any of the requirements of the Information for Bidders, and the Surety hereby waives notice of any such postponements, extensions, or waivers.

IN WITNESS WHEREOF, the Principal and the Surety have hereunto set their hands and seals and such of them as are corporations have caused their corporate seals to be hereto affixed and these presents to be signed by their proper officers the 18th day of November, 2019.

(Seal)

ADC Construction, LLC

(L.S.)

Principal

By:

(Seal)

Travelers Casualty and Surety Company of America

Surety

By:

Robert M. Kempner, Attorney-in-Fact

BID BOND 3

ACKNOWLEDGMENT OF PRINCIPAL, IF A CORPORATION

State of _____ County of _____ ss:
On this _____ day of _____, _____, before me personally came _____ to me known, who, being by me duly sworn, did depose and say that he resides at _____ that he is the _____ of _____ the corporation described in and which executed the foregoing instrument; that he knows the seal of said corporation; that one of the seals affixed to said instrument is such seal; that it was so affixed by order of the directors of said corporation, and that he signed his name thereto by like order.

Notary Public

ACKNOWLEDGMENT OF PRINCIPAL, IF A PARTNERSHIP

State of New York County of QUEENS ss:
On this 5TH day of DEC, 2019, before me personally appeared DOMENICK CIPOLLONE to me known and known to me to be one of the members of the firm of ADC CONSTRUCTION described in and who executed the foregoing instrument, and he acknowledged to me that he executed the same as and for the act and deed of said firm.

MELISSA GALLAGHER
NOTARY PUBLIC, STATE OF NEW YORK
Registration No. 01GA6013314
Qualified in Queens County
Commission Expires 09-14-2022

Melissa Gallagher
Notary Public

ACKNOWLEDGMENT OF PRINCIPAL, IF AN INDIVIDUAL

State of _____ County of _____ ss:
On this _____ day of _____, _____, before me personally appeared _____ to me known and known to me to be the person described in and who executed the foregoing instrument and acknowledged that he executed the same.

Notary Public

AFFIX ACKNOWLEDGMENTS AND JUSTIFICATION OF SURETIES



**Travelers Casualty and Surety Company of America
Travelers Casualty and Surety Company
St. Paul Fire and Marine Insurance Company**

POWER OF ATTORNEY

KNOW ALL MEN BY THESE PRESENTS: That Travelers Casualty and Surety Company of America, Travelers Casualty and Surety Company, and St. Paul Fire and Marine Insurance Company are corporations duly organized under the laws of the State of Connecticut (herein collectively called the "Companies"), and that the Companies do hereby make, constitute and appoint **Robert M. Kempner** of **Plainview, New York**, their true and lawful Attorney-in-Fact to sign, execute, seal and acknowledge any and all bonds, recognizances, conditional undertakings and other writings obligatory in the nature thereof on behalf of the Companies in their business of guaranteeing the fidelity of persons, guaranteeing the performance of contracts and executing or guaranteeing bonds and undertakings required or permitted in any actions or proceedings allowed by law.

IN WITNESS WHEREOF, the Companies have caused this instrument to be signed, and their corporate seals to be hereto affixed, this **3rd** day of **February**, 2017.



State of Connecticut

City of Hartford ss.

By: 
Robert L. Raney, Senior Vice President

On this the **3rd** day of **February**, 2017, before me personally appeared **Robert L. Raney**, who acknowledged himself to be the Senior Vice President of Travelers Casualty and Surety Company of America, Travelers Casualty and Surety Company, and St. Paul Fire and Marine Insurance Company, and that he, as such, being authorized so to do, executed the foregoing instrument for the purposes therein contained by signing on behalf of the corporations by himself as a duly authorized officer.

In Witness Whereof, I hereunto set my hand and official seal.

My Commission expires the **30th** day of **June**, 2021

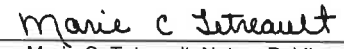

Marie C. Tetreault, Notary Public

This Power of Attorney is granted under and by the authority of the following resolutions adopted by the Boards of Directors of Travelers Casualty and Surety Company of America, Travelers Casualty and Surety Company, and St. Paul Fire and Marine Insurance Company, which resolutions are now in full force and effect, reading as follows:

RESOLVED, that the Chairman, the President, any Vice Chairman, any Executive Vice President, any Senior Vice President, any Vice President, any Second Vice President, the Treasurer, any Assistant Treasurer, the Corporate Secretary or any Assistant Secretary may appoint Attorneys-in-Fact and Agents to act for and on behalf of the Company and may give such appointee such authority as his or her certificate of authority may prescribe to sign with the Company's name and seal with the Company's seal bonds, recognizances, contracts of indemnity, and other writings obligatory in the nature of a bond, recognizance, or conditional undertaking, and any of said officers or the Board of Directors at any time may remove any such appointee and revoke the power given him or her; and it is

FURTHER RESOLVED, that the Chairman, the President, any Vice Chairman, any Executive Vice President, any Senior Vice President or any Vice President may delegate all or any part of the foregoing authority to one or more officers or employees of this Company, provided that each such delegation is in writing and a copy thereof is filed in the office of the Secretary; and it is

FURTHER RESOLVED, that any bond, recognizance, contract of indemnity, or writing obligatory in the nature of a bond, recognizance, or conditional undertaking shall be valid and binding upon the Company when (a) signed by the President, any Vice Chairman, any Executive Vice President, any Senior Vice President or any Vice President, any Second Vice President, the Treasurer, any Assistant Treasurer, the Corporate Secretary or any Assistant Secretary and duly attested and sealed with the Company's seal by a Secretary or Assistant Secretary; or (b) duly executed (under seal, if required) by one or more Attorneys-in-Fact and Agents pursuant to the power prescribed in his or her certificate or their certificates of authority or by one or more Company officers pursuant to a written delegation of authority; and it is

FURTHER RESOLVED, that the signature of each of the following officers: President, any Executive Vice President, any Senior Vice President, any Vice President, any Assistant Vice President, any Secretary, any Assistant Secretary, and the seal of the Company may be affixed by facsimile to any Power of Attorney or to any certificate relating thereto appointing Resident Vice Presidents, Resident Assistant Secretaries or Attorneys-in-Fact for purposes only of executing and attesting bonds and undertakings and other writings obligatory in the nature thereof, and any such Power of Attorney or certificate bearing such facsimile signature or facsimile seal shall be valid and binding upon the Company and any such power so executed and certified by such facsimile signature and facsimile seal shall be valid and binding on the Company in the future with respect to any bond or understanding to which it is attached.

I, **Kevin E. Hughes**, the undersigned, Assistant Secretary of Travelers Casualty and Surety Company of America, Travelers Casualty and Surety Company, and St. Paul Fire and Marine Insurance Company, do hereby certify that the above and foregoing is a true and correct copy of the Power of Attorney executed by said Companies, which remains in full force and effect.

Dated this 18th day of November, 2019



Kevin E. Hughes, Assistant Secretary

**To verify the authenticity of this Power of Attorney, please call us at 1-800-421-3880.
Please refer to the above-named Attorney-in-Fact and the details of the bond to which the power is attached.**

**TRAVELERS CASUALTY AND SURETY COMPANY OF AMERICA
HARTFORD, CT 06183**

PRINCIPAL'S ACKNOWLEDGMENT

State of _____, County of _____, } ss.

On this _____ day of _____ in the year 20____, before me, the undersigned, personally appeared _____, personally known to me or proved to me on the basis of satisfactory evidence to be the individual whose name is subscribed to the within instrument and acknowledged to me that he/she executed the same in his/her capacity, and that by his/her signature on the instrument, the individual, or the person upon behalf of which the individual acted, executed the instrument.

Notary Public

SURETY COMPANY'S ACKNOWLEDGMENT

State of New York, County of Nassau, } ss.

On this 18th day of November in the year 2019, before me, the undersigned, personally appeared Robert M. Kempner, personally known to me, and who, being by me duly sworn, did depose and say: That he/she resides in Centerport, NY; that he/she is Attorney-in-Fact of **TRAVELERS CASUALTY AND SURETY COMPANY OF AMERICA**, the corporation described in and which executed the within instrument; that he/she knows the corporate seal of said Company; that the seal affixed to said instrument is such corporate seal; and that he/she signed said instrument as Attorney-in-Fact by authority of the Board of Directors of said Company; and affiant did further depose and say that the Superintendent of the State of New York Department of Financial Services has, pursuant to Section 1111 of the New York Insurance Law, issued to **TRAVELERS CASUALTY AND SURETY COMPANY OF AMERICA** his/her certificate that said Company is qualified to become and be accepted as surety or guarantor on all bonds, undertakings, recognizances, guaranties, and other obligations required or permitted by law; and that such certificate has not been revoked.

LYNN ANN INFANTI
Notary Public, State of New York
No. 011N6004351
Qualified in Suffolk County
Commission Expires March 23, 2022



Notary Public

FINANCIAL STATEMENT AS OF DECEMBER 31, 2018
AS FILED IN THE STATE OF NEW YORK
CAPITAL STOCK \$ 6,480,000

ASSETS	LIABILITIES & SURPLUS
CASH AND INVESTED CASH	UNEARNED PREMIUMS
\$ 36,728,596	\$ 979,007,378
BONDS	LOSSES
3,507,432,239	750,995,504
STOCKS	LOSS ADJUSTMENT EXPENSES
294,199,598	168,673,871
INVESTMENT INCOME DUE AND ACCRUED	COMMISSIONS
38,287,129	45,868,584
OTHER INVESTED ASSETS	TAXES, LICENSES AND FEES
3,507,839	14,584,663
PREMIUM BALANCES	OTHER EXPENSES
250,478,792	43,858,534
NET DEFERRED TAX ASSET	CURRENT FEDERAL AND FOREIGN INCOME TAXES
48,781,239	10,143,037
REINSURANCE RECOVERABLE	REMITTANCES AND ITEMS NOT ALLOCATED
29,278,755	21,277,153
SECURITIES LENDING REINVESTED COLLATERAL ASSETS	AMOUNTS WITHHELD / RETAINED BY COMPANY FOR OTHERS
14,277,262	30,289,553
RECEIVABLES FROM PARENT, SUBSIDIARIES AND AFFILIATES	RETROACTIVE REINSURANCE RESERVE ASSUMED
27,813,266	810,360
ASSUMED REINSURANCE RECEIVABLE AND PAYABLE	POLICYHOLDER DIVIDENDS
626,488	10,410,755
OTHER ASSETS	PROVISION FOR REINSURANCE
4,936,229	7,641,356
	ADVANCE PREMIUM
	1,609,777
	REINSURANCE PAYABLE ON PAID LOSSES & LOSS ADJ. EXPENSES
	868,002
	PAYABLE FOR SECURITIES LENDING
	14,277,262
	CEDED REINSURANCE NET PREMIUMS PAYABLE
	46,469,976
	OTHER ACCRUED EXPENSES AND LIABILITIES
	335,489
	<u>TOTAL LIABILITIES</u>
	<u>\$ 2,145,120,254</u>
	CAPITAL STOCK
	\$ 6,480,000
	PAID IN SURPLUS
	433,803,760
	OTHER SURPLUS
	1,670,943,418
	<u>TOTAL SURPLUS TO POLICYHOLDERS</u>
	<u>\$ 2,111,227,178</u>
TOTAL ASSETS	TOTAL LIABILITIES & SURPLUS
<u>\$ 4,256,347,432</u>	<u>\$ 4,256,347,432</u>

**TRAVELERS CASUALTY AND SURETY COMPANY OF AMERICA
HARTFORD, CT 06183**

PRINCIPAL'S ACKNOWLEDGMENT

State of _____, County of _____, } ss.

On this _____ day of _____ in the year 20____, before me, the undersigned, personally appeared _____, personally known to me or proved to me on the basis of satisfactory evidence to be the individual whose name is subscribed to the within instrument and acknowledged to me that he/she executed the same in his/her capacity, and that by his/her signature on the instrument, the individual, or the person upon behalf of which the individual acted, executed the instrument.

Notary Public

SURETY COMPANY'S ACKNOWLEDGMENT

State of New York, County of Nassau, } ss.

On this 18th day of November in the year 2019, before me, the undersigned, personally appeared Robert M. Kempner, personally known to me, and who, being by me duly sworn, did depose and say: That he/she resides in Centerport, NY; that he/she is Attorney-in-Fact of **TRAVELERS CASUALTY AND SURETY COMPANY OF AMERICA**, the corporation described in and which executed the within instrument; that he/she knows the corporate seal of said Company; that the seal affixed to said instrument is such corporate seal; and that he/she signed said instrument as Attorney-in-Fact by authority of the Board of Directors of said Company; and affiant did further depose and say that the Superintendent of the State of New York Department of Financial Services has, pursuant to Section 1111 of the New York Insurance Law, issued to **TRAVELERS CASUALTY AND SURETY COMPANY OF AMERICA** his/her certificate that said Company is qualified to become and be accepted as surety or guarantor on all bonds, undertakings, recognizances, guaranties, and other obligations required or permitted by law; and that such certificate has not been revoked.

LYNN ANN INFANTI
Notary Public, State of New York
No. 011N6004351
Qualified in Suffolk County
Commission Expires March 23, 2022



Notary Public

FINANCIAL STATEMENT AS OF DECEMBER 31, 2018
AS FILED IN THE STATE OF NEW YORK
CAPITAL STOCK \$ 6,480,000

ASSETS		LIABILITIES & SURPLUS	
CASH AND INVESTED CASH	\$ 36,728,596	UNEARNED PREMIUMS	\$ 979,007,378
BONDS	3,507,432,239	LOSSES	750,995,504
STOCKS	294,199,598	LOSS ADJUSTMENT EXPENSES	168,673,871
INVESTMENT INCOME DUE AND ACCRUED	38,287,129	COMMISSIONS	45,868,584
OTHER INVESTED ASSETS	3,507,839	TAXES, LICENSES AND FEES	14,584,663
PREMIUM BALANCES	250,478,792	OTHER EXPENSES	43,858,534
NET DEFERRED TAX ASSET	48,781,239	CURRENT FEDERAL AND FOREIGN INCOME TAXES	10,143,037
REINSURANCE RECOVERABLE	29,278,755	REMITTANCES AND ITEMS NOT ALLOCATED	21,277,153
SECURITIES LENDING REINVESTED COLLATERAL ASSETS	14,277,262	AMOUNTS WITHHELD / RETAINED BY COMPANY FOR OTHERS	30,289,553
RECEIVABLES FROM PARENT, SUBSIDIARIES AND AFFILIATES	27,813,266	RETROACTIVE REINSURANCE RESERVE ASSUMED	810,360
ASSUMED REINSURANCE RECEIVABLE AND PAYABLE	626,488	POLICYHOLDER DIVIDENDS	10,410,755
OTHER ASSETS	4,936,229	PROVISION FOR REINSURANCE	7,641,356
		ADVANCE PREMIUM	1,609,777
		REINSURANCE PAYABLE ON PAID LOSSES & LOSS ADJ. EXPENSES	868,002
		PAYABLE FOR SECURITIES LENDING	14,277,262
		CEDED REINSURANCE NET PREMIUMS PAYABLE	46,469,976
		OTHER ACCRUED EXPENSES AND LIABILITIES	335,489
		TOTAL LIABILITIES	\$ 2,145,120,254
		CAPITAL STOCK	\$ 6,480,000
		PAID IN SURPLUS	433,803,760
		OTHER SURPLUS	1,670,943,418
		TOTAL SURPLUS TO POLICYHOLDERS	\$ 2,111,227,178
TOTAL ASSETS	\$ 4,256,347,432	TOTAL LIABILITIES & SURPLUS	\$ 4,256,347,432



**Travelers Casualty and Surety Company of America
Travelers Casualty and Surety Company
St. Paul Fire and Marine Insurance Company**

POWER OF ATTORNEY

KNOW ALL MEN BY THESE PRESENTS: That Travelers Casualty and Surety Company of America, Travelers Casualty and Surety Company, and St. Paul Fire and Marine Insurance Company are corporations duly organized under the laws of the State of Connecticut (herein collectively called the "Companies"), and that the Companies do hereby make, constitute and appoint **Robert M. Kempner of Plainview, New York**, their true and lawful Attorney-in-Fact to sign, execute, seal and acknowledge any and all bonds, recognizances, conditional undertakings and other writings obligatory in the nature thereof on behalf of the Companies in their business of guaranteeing the fidelity of persons, guaranteeing the performance of contracts and executing or guaranteeing bonds and undertakings required or permitted in any actions or proceedings allowed by law.

IN WITNESS WHEREOF, the Companies have caused this instrument to be signed, and their corporate seals to be hereto affixed, this **3rd** day of **February**, 2017.



State of Connecticut

City of Hartford ss.

By: 
Robert L. Raney, Senior Vice President

On this the **3rd** day of **February**, 2017, before me personally appeared **Robert L. Raney**, who acknowledged himself to be the Senior Vice President of Travelers Casualty and Surety Company of America, Travelers Casualty and Surety Company, and St. Paul Fire and Marine Insurance Company, and that he, as such, being authorized so to do, executed the foregoing instrument for the purposes therein contained by signing on behalf of the corporations by himself as a duly authorized officer.

In Witness Whereof, I hereunto set my hand and official seal.

My Commission expires the **30th** day of **June**, 2021

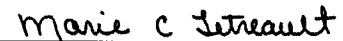

Marie C. Tetreault, Notary Public

This Power of Attorney is granted under and by the authority of the following resolutions adopted by the Boards of Directors of Travelers Casualty and Surety Company of America, Travelers Casualty and Surety Company, and St. Paul Fire and Marine Insurance Company, which resolutions are now in full force and effect, reading as follows:

RESOLVED, that the Chairman, the President, any Vice Chairman, any Executive Vice President, any Senior Vice President, any Vice President, any Second Vice President, the Treasurer, any Assistant Treasurer, the Corporate Secretary or any Assistant Secretary may appoint Attorneys-in-Fact and Agents to act for and on behalf of the Company and may give such appointee such authority as his or her certificate of authority may prescribe to sign with the Company's name and seal with the Company's seal bonds, recognizances, contracts of indemnity, and other writings obligatory in the nature of a bond, recognizance, or conditional undertaking, and any of said officers or the Board of Directors at any time may remove any such appointee and revoke the power given him or her; and it is

FURTHER RESOLVED, that the Chairman, the President, any Vice Chairman, any Executive Vice President, any Senior Vice President or any Vice President may delegate all or any part of the foregoing authority to one or more officers or employees of this Company, provided that each such delegation is in writing and a copy thereof is filed in the office of the Secretary; and it is

FURTHER RESOLVED, that any bond, recognizance, contract of indemnity, or writing obligatory in the nature of a bond, recognizance, or conditional undertaking shall be valid and binding upon the Company when (a) signed by the President, any Vice Chairman, any Executive Vice President, any Senior Vice President or any Vice President, any Second Vice President, the Treasurer, any Assistant Treasurer, the Corporate Secretary or any Assistant Secretary and duly attested and sealed with the Company's seal by a Secretary or Assistant Secretary; or (b) duly executed (under seal, if required) by one or more Attorneys-in-Fact and Agents pursuant to the power prescribed in his or her certificate or their certificates of authority or by one or more Company officers pursuant to a written delegation of authority; and it is

FURTHER RESOLVED, that the signature of each of the following officers: President, any Executive Vice President, any Senior Vice President, any Vice President, any Assistant Vice President, any Secretary, any Assistant Secretary, and the seal of the Company may be affixed by facsimile to any Power of Attorney or to any certificate relating thereto appointing Resident Vice Presidents, Resident Assistant Secretaries or Attorneys-in-Fact for purposes only of executing and attesting bonds and undertakings and other writings obligatory in the nature thereof, and any such Power of Attorney or certificate bearing such facsimile signature or facsimile seal shall be valid and binding upon the Company and any such power so executed and certified by such facsimile signature and facsimile seal shall be valid and binding on the Company in the future with respect to any bond or understanding to which it is attached.

I, **Kevin E. Hughes**, the undersigned, Assistant Secretary of Travelers Casualty and Surety Company of America, Travelers Casualty and Surety Company, and St. Paul Fire and Marine Insurance Company, do hereby certify that the above and foregoing is a true and correct copy of the Power of Attorney executed by said Companies, which remains in full force and effect.

Dated this 18th day of November, 2019



Kevin E. Hughes, Assistant Secretary

**To verify the authenticity of this Power of Attorney, please call us at 1-800-421-3880.
Please refer to the above-named Attorney-in-Fact and the details of the bond to which the power is attached.**

**TRAVELERS CASUALTY AND SURETY COMPANY OF AMERICA
HARTFORD, CT 06183**

PRINCIPAL'S ACKNOWLEDGMENT

State of _____, County of _____,) ss.

On this _____ day of _____ in the year 20____, before me, the undersigned, personally appeared _____, personally known to me or proved to me on the basis of satisfactory evidence to be the individual whose name is subscribed to the within instrument and acknowledged to me that he/she executed the same in his/her capacity, and that by his/her signature on the instrument, the individual, or the person upon behalf of which the individual acted, executed the instrument.

Notary Public

SURETY COMPANY'S ACKNOWLEDGMENT

State of New York, County of Nassau,) ss.

On this 18th day of November in the year 2019, before me, the undersigned, personally appeared Robert M. Kempner, personally known to me, and who, being by me duly sworn, did depose and say: That he/she resides in Centerport, NY; that he/she is Attorney-in-Fact of **TRAVELERS CASUALTY AND SURETY COMPANY OF AMERICA**, the corporation described in and which executed the within instrument; that he/she knows the corporate seal of said Company; that the seal affixed to said instrument is such corporate seal; and that he/she signed said instrument as Attorney-in-Fact by authority of the Board of Directors of said Company; and affiant did further depose and say that the Superintendent of the State of New York Department of Financial Services has, pursuant to Section 1111 of the New York Insurance Law, issued to **TRAVELERS CASUALTY AND SURETY COMPANY OF AMERICA** his/her certificate that said Company is qualified to become and be accepted as surety or guarantor on all bonds, undertakings, recognizances, guaranties, and other obligations required or permitted by law; and that such certificate has not been revoked.

LYNN ANN INFANTI
Notary Public, State of New York
No. 01IN6004351
Qualified in Suffolk County
Commission Expires March 23, 2022



Notary Public

TRAVELERS CASUALTY AND SURETY COMPANY OF AMERICA
HARTFORD, CONNECTICUT 06183

FINANCIAL STATEMENT AS OF DECEMBER 31, 2018
AS FILED IN THE STATE OF NEW YORK
CAPITAL STOCK \$ 6,480,000

ASSETS	LIABILITIES & SURPLUS
CASH AND INVESTED CASH	UNEARNED PREMIUMS
\$ 36,728,596	\$ 979,007,378
BONDS	LOSSES
3,507,432,239	750,995,504
STOCKS	LOSS ADJUSTMENT EXPENSES
294,199,598	166,673,871
INVESTMENT INCOME DUE AND ACCRUED	COMMISSIONS
38,287,129	45,868,584
OTHER INVESTED ASSETS	TAXES, LICENSES AND FEES
3,507,839	14,584,663
PREMIUM BALANCES	OTHER EXPENSES
250,478,792	43,858,534
NET DEFERRED TAX ASSET	CURRENT FEDERAL AND FOREIGN INCOME TAXES
48,781,239	10,143,037
REINSURANCE RECOVERABLE	REMITTANCES AND ITEMS NOT ALLOCATED
29,278,755	21,277,153
SECURITIES LENDING REINVESTED COLLATERAL ASSETS	AMOUNTS WITHHELD / RETAINED BY COMPANY FOR OTHERS
14,277,262	30,289,553
RECEIVABLES FROM PARENT, SUBSIDIARIES AND AFFILIATES	RETROACTIVE REINSURANCE RESERVE ASSUMED
27,813,266	810,360
ASSUMED REINSURANCE RECEIVABLE AND PAYABLE	POLICYHOLDER DIVIDENDS
626,488	10,410,755
OTHER ASSETS	PROVISION FOR REINSURANCE
4,936,229	7,641,356
	ADVANCE PREMIUM
	1,608,777
	REINSURANCE PAYABLE ON PAID LOSSES & LOSS ADJ. EXPENSES
	868,002
	PAYABLE FOR SECURITIES LENDING
	14,277,262
	CEDED REINSURANCE NET PREMIUMS PAYABLE
	46,469,976
	OTHER ACCRUED EXPENSES AND LIABILITIES
	335,489
	TOTAL LIABILITIES
	\$ 2,145,120,254
	CAPITAL STOCK
	\$ 6,480,000
	PAID IN SURPLUS
	433,803,760
	OTHER SURPLUS
	1,670,943,418
	TOTAL SURPLUS TO POLICYHOLDERS
	\$ 2,111,227,178
TOTAL ASSETS	TOTAL LIABILITIES & SURPLUS
\$ 4,256,347,432	\$ 4,256,347,432

BID BONDS
BID BOND 1
FORM OF BID BOND

KNOW ALL MEN BY THESE PRESENTS. That we, _____

hereinafter referred to as the "Principal", and _____

hereinafter referred to as the "Surety" are held and firmly bound to THE CITY OF NEW YORK, hereinafter referred to as the "CITY", or to its successors and assigns in the penal sum of _____

(\$ _____), Dollars lawful money of the United States, for the payment of which said sum of money well and truly to be made, we, and each of us, bind ourselves, our heirs, executors, administrators, successors and assigns, jointly and severally, firmly by these presents.

Whereas, the Principal is about to submit (or has submitted) to the City the accompanying proposal, hereby made a part hereof, to enter into a contract in writing for _____

NOW, THEREFORE, the conditions of this obligation are such that if the Principal shall not withdraw said Proposal without the consent of the City for a period of forty-five (45) days after the opening of bids and in the event of acceptance of the Principal's Proposal by the City, if the Principal shall:

(a) Within ten (10) days after notification by the City, execute in quadruplicate and deliver to the City all the executed counterparts of the Contract in the form set forth in the Contract Documents, in accordance with the proposal as accepted, and

(b) Furnish a performance bond and separate payment bond, as may be required by the City, for the faithful performance and proper fulfillment of such Contract, which bonds shall be satisfactory in all respects to the City and shall be executed by good and sufficient sureties, and

(c) In all respects perform the agreement created by the acceptance of said Proposal as provided in the Information for Bidders, bound herewith and made a part hereof, or if the City shall reject the aforesaid Proposal, then this obligation shall be null and void; otherwise to remain in full force and effect.

BID BOND 2

In the event that the Proposal of the Principal shall be accepted and the Contract be awarded to the Principal the Surety hereunder agrees subject only to the payment by the Principal of the premium therefore, if requested by the City, to write the aforementioned performance and payment bonds in the form set forth in the Contract Documents.

It is expressly understood and agreed that the liability of the Surety for any and all claims hereunder shall in no event exceed the penal amount of this obligation as herein stated.

There shall be no liability under this bond if, in the event of the acceptance of the Principal's Proposal by the City, either a performance bond or payment bond, or both, shall not be required by the City on or before the 30th day after the date on which the City signs the Contract.

The surety, for the value received, hereby stipulates and agrees that the obligations of the Surety and its bond shall in no way be impaired or affected by any postponements of the date upon which the City will receive or open bids, or by any extensions of the time within which the City may accept the Principal's Proposal, or by any waiver by the City of any of the requirements of the Information for Bidders, and the Surety hereby waives notice of any such postponements, extensions, or waivers.

IN WITNESS WHEREOF, the Principal and the Surety have hereunto set their hands and seals and such of them as are corporations have caused their corporate seals to be hereto affixed and these presents to be signed by their proper officers the ____ day of _____, _____.

(Seal)

_____ (L.S.)
Principal

By: _____

(Seal)

Surety

By: _____

BID BOND 3

ACKNOWLEDGMENT OF PRINCIPAL, IF A CORPORATION

State of _____ County of _____ ss:
On this _____ day of _____, _____, before me personally came
_____ to me known, who, being by me duly sworn, did
depose and say that he/she/they resides at

that he/she/they is the _____ of

the corporation described in and which executed the foregoing instrument; that he/she/they knows
the seal of said corporation; that one of the seals affixed to said instrument is such seal; that it
was so affixed by order of the directors of said corporation, and that he/she/they signed his name
thereto by like order.

Notary Public

ACKNOWLEDGMENT OF PRINCIPAL, IF A PARTNERSHIP

State of _____ County of _____ ss:
On this _____ day of _____, _____, before me personally
appeared _____ to me known and known to me to be one of
the members of the firm of _____ described in and
who executed the foregoing instrument, and he/she/they acknowledged to me that he/she/they
executed the same as and for the act and deed of said firm.

Notary Public

ACKNOWLEDGMENT OF PRINCIPAL, IF AN INDIVIDUAL

State of _____ County of _____ ss:
On this _____ day of _____, _____, before me personally
appeared _____ to me known and known to me to be the
person described in and who executed the foregoing instrument and acknowledged that
he/she/they executed the same.

Notary Public

AFFIX ACKNOWLEDGMENTS AND JUSTIFICATION OF SURETIES

(NO TEXT ON THIS PAGE)

Qualification Form

List previous projects completed to meet the special experience requirements for this contract. If necessary, please photocopy this form for submission of all required projects

Name of Contractor: ADC Construction, LLC

Name of Project: HWQ-1027

Location of Project: Reconstruction of Roadways at LIRR Underpasses Queens

Owner or Owner's representative familiar with the work performed

Name: Donald Granger, P.E.

Title: NYC DDC Queens Borough Director

Phone Number: (718) 391-1968

Brief description of work completed: Sewer, Watermain and Roadway Reconstruction

Was the work performed as a prime or a subcontractor: Prime

Amount of Contract or Subcontract: \$8,058,831.07

Date of Completion: 4/6/2009

Name of Contractor: ADC Construction, LLC

Name of Project: SEQ-002666

Location of Project: Trench Restoration Project No. 11, Various Locations Queens

Owner or Owner's representative familiar with the work performed

Name: Donald Granger, P.E.

Title: NYC DDC Queens Borough Director

Phone Number: (718) 391-1968

Brief description of work completed: Trench Restoration

Was the work performed as a prime or a subcontractor: Prime

Amount of Contract or Subcontract: \$2,896,190.00

Date of Completion: 6/30/2009



Qualification Form

List previous projects completed to meet the special experience requirements for this contract. If necessary, please photocopy this form for submission of all required projects

Name of Contractor: ADC Construction, LLC

Name of Project: SEQ-200465

Location of Project: Reconstruction of Sewers in Union Tpke Queens

Owner or Owner's representative familiar with the work performed

Name: Donald Granger, P.E.

Title: NYC DDC Queens Borough Director

Phone Number: (718) 391-1968

Brief description of work completed: Sewer & Watermains

Was the work performed as a prime or a subcontractor: Prime

Amount of Contract or Subcontract: \$1,663,148.10

Date of Completion: 5/22/2009

Name of Contractor: ADC Construction, LLC

Name of Project: HWKP2028

Location of Project: Reconstruction of Roadways in the Paerdegat Ave Area Brooklyn

Owner or Owner's representative familiar with the work performed

Name: Robert Yueh, P.E.

Title: NYC DDC Brooklyn Borough Director

Phone Number: (718) 250-5057

Brief description of work completed: Sewer, Watermain and Roadway Reconstruction

Was the work performed as a prime or a subcontractor: Prime

Amount of Contract or Subcontract: \$4,142,120.40

Date of Completion: 12/17/2009



Qualification Form

List previous projects completed to meet the special experience requirements for this contract. If necessary, please photocopy this form for submission of all required projects

Name of Contractor: ADC Construction, LLC

Name of Project: SEX00201T

Location of Project: Collapsed Sewer Various Locations Bronx

Owner or Owner's representative familiar with the work performed

Name: Moolaman Abraham, P.E.

Title: NYC DEP Chief Emergency Construction

Phone Number: (718) 595-4200

Brief description of work completed: Sewer & Watermains

Was the work performed as a prime or a subcontractor: Prime

Amount of Contract or Subcontract: \$4,584,542.20

Date of Completion: 7/25/2010

Name of Contractor: ADC Construction, LLC

Name of Project: SEX00201U

Location of Project: Collapsed Sewer Various Locations Bronx

Owner or Owner's representative familiar with the work performed

Name: James Moran, P.E.

Title: NYC DEP Chief Emergency Construction

Phone Number: (718) 595-4200

Brief description of work completed: Sewer & Watermains

Was the work performed as a prime or a subcontractor: Prime

Amount of Contract or Subcontract: \$4,176,682.90

Date of Completion: 9/4/2011

Qualification Form

List previous projects completed to meet the special experience requirements for this contract. If necessary, please photocopy this form for submission of all required projects

Name of Contractor: ADC Construction, LLC

Name of Project: HWP2013KC

Location of Project: Complex Pedestrian Ramps Various Location Brooklyn

Owner or Owner's representative familiar with the work performed

Name: Robert Yueh, P.E.

Title: NYC DDC Brooklyn Borough Director

Phone Number: (718) 391-1937

Brief description of work completed: Highway

Was the work performed as a prime or a subcontractor: Prime

Amount of Contract or Subcontract: \$3,158,000.00

Date of Completion: 10/30/2015

Name of Contractor: ADC Construction, LLC

Name of Project: HWK1129

Location of Project: Reconstruction of Nostrand Ave Brooklyn

Owner or Owner's representative familiar with the work performed

Name: Robert Yueh, P.E.

Title: NYC DDC Brooklyn Borough Director

Phone Number: (718) 391-1937

Brief description of work completed: Sewer, Water Mains Highway

Was the work performed as a prime or a subcontractor: Prime

Amount of Contract or Subcontract: \$23,509,000.00

Date of Completion: 10/30/2015

QUALIFICATION FORM

List previous projects completed to meet the special experience requirements for this contract.
Please photocopy this form for submission of all required projects.

Name of Contractor: _____

Name of Project: _____

Location of Project: _____

Owner or Owner's representative (Architect or Engineer) who is familiar with the work performed:

Name: _____

Title: _____ Phone Number: _____

Brief description of the Project completed or the Project in progress: _____

Was the Project performed as a prime, a subcontractor or a sub-subcontractor: _____

Amount of Contract, Subcontract or Sub-subcontract: _____

Start Date and Completion Date: _____

Name of Contractor: _____

Name of Project: _____

Location of Project: _____

Owner or Owner's representative (Architect or Engineer) who is familiar with the work performed:

Name: _____

Title: _____ Phone Number: _____

Brief description of the Project completed or the Project in progress: _____

Was the Project performed as a prime, a subcontractor or a sub-subcontractor: _____

Amount of Contract, Subcontract or Sub-subcontract: _____

Start Date and Completion Date: _____

QUALIFICATION FORM

Name of Contractor: _____

Name of Project: _____

Location of Project: _____

Owner or Owner's representative (Architect or Engineer) who is familiar with the work performed:

Name: _____

Title: _____ Phone Number: _____

Brief description of the Project completed or the Project in progress: _____

Was the Project performed as a prime, a subcontractor or a sub-subcontractor: _____

Amount of Contract, Subcontract or Sub-subcontract: _____

Start Date and Completion Date: _____

Name of Contractor: _____

Name of Project: _____

Location of Project: _____

Owner or Owner's representative (Architect or Engineer) who is familiar with the work performed:

Name: _____

Title: _____ Phone Number: _____

Brief description of the Project completed or the Project in progress: _____

Was the Project performed as a prime, a subcontractor or a sub-subcontractor: _____

Amount of Contract, Subcontract or Sub-subcontract: _____

Start Date and Completion Date: _____

QUALIFICATION FORM

Name of Contractor: _____

Name of Project: _____

Location of Project: _____

Owner or Owner's representative (Architect or Engineer) who is familiar with the work performed:

Name: _____

Title: _____ Phone Number: _____

Brief description of the Project completed or the Project in progress: _____

Was the Project performed as a prime, a subcontractor or a sub-subcontractor: _____

Amount of Contract, Subcontract or Sub-subcontract: _____

Start Date and Completion Date: _____

Name of Contractor: _____

Name of Project: _____

Location of Project: _____

Owner or Owner's representative (Architect or Engineer) who is familiar with the work performed:

Name: _____

Title: _____ Phone Number: _____

Brief description of the Project completed or the Project in progress: _____

Was the Project performed as a prime, a subcontractor or a sub-subcontractor: _____

Amount of Contract, Subcontract or Sub-subcontract: _____

Start Date and Completion Date: _____

QUALIFICATION FORM

Name of Contractor: _____

Name of Project: _____

Location of Project: _____

Owner or Owner's representative (Architect or Engineer) who is familiar with the work performed:

Name: _____

Title: _____ Phone Number: _____

Brief description of the Project completed or the Project in progress: _____

Was the Project performed as a prime, a subcontractor or a sub-subcontractor: _____

Amount of Contract, Subcontract or Sub-subcontract: _____

Start Date and Completion Date: _____

Name of Contractor: _____

Name of Project: _____

Location of Project: _____

Owner or Owner's representative (Architect or Engineer) who is familiar with the work performed:

Name: _____

Title: _____ Phone Number: _____

Brief description of the Project completed or the Project in progress: _____

Was the Project performed as a prime, a subcontractor or a sub-subcontractor: _____

Amount of Contract, Subcontract or Sub-subcontract: _____

Start Date and Completion Date: _____

#1

SCHEDULE B: M/WBE UTILIZATION PLAN

Tax ID #: _____

APT E-PIN #: 85020B0005

SCHEDULE B – M/WBE Utilization Plan

Part I: M/WBE Participation Goals

Part I to be completed by contracting agency

Contract Overview

APT E- Pin #	85020B0005	FMS Project ID#:	SEQBN11
Project Title/ Agency PIN #	RECONSTRUCTION OF EXISTING SEWERS, NORTH QUEENS/ 8502019SE0033C		
Bid/Proposal Response Date	December 5 th 2019		
Contracting Agency	Department of Design and Construction		
Agency Address	30-30 Thomson Ave.	City	Long Island City
		State	NY
		Zip Code	11101
Contact Person	Emmanuel Charles	Title	MWBE Liaison & Compliance Analyst
Telephone #	(718) 391-1450	Email	CharlesEm@ddc.nyc.gov

Project Description *(attach additional pages if necessary)*

RECONSTRUCTION OF EXISTING SEWERS, NORTH QUEENS
Together With All Work Incidental Thereto
BOROUGH OF QUEENS
CITY OF NEW YORK

M/WBE Participation Goals for Services

Enter the percentage amount for each group or for an unspecified goal. Please note that there are no goals for Asian Americans in Professional Services.

Prime Contract Industry: **Construction**

Group	Percentage
Unspecified	4%
or	
Black American	UNSPECIFIED*
Hispanic American	UNSPECIFIED*
Asian American	UNSPECIFIED*
Women	UNSPECIFIED*
Total Participation	4%

Line 1

**Note: For this procurement, individual ethnicity and gender goals are not specified. The Total Participation Goal for construction contracts may be met by using either Black-American, Hispanic-American, Asian American, or Women certified firms or any combination of such firms.*

(NO TEXT ON THIS PAGE)

Tax ID #: _____

APT E-PIN #: 85020B0005

SCHEDULE B - Part II: M/WBE Participation Plan

Part II to be completed by the bidder/proposer.

Please note: For Non-M/WBE Prime Contractors who will NOT subcontract any services and will self-perform the entire contract, you must obtain a FULL waiver by completing the Waiver Application on pages 5 and 6 and timely submitting it to the contracting agency pursuant to the Notice to Prospective Contractors. Once a FULL WAIVER is granted, it must be included with your bid or proposal and you do not have to complete or submit this form with your bid or proposal.

Section I: Prime Contractor Contact Information

Tax ID # 113353007 FMS Vendor ID # 622618
 Business Name ADC CONSTRUCTION Contact Person JOSEPH AIELLO
 Address 58-08 48 ST MASPETH NY 11378
 Telephone # 718 628 5555 Email ADCCONSTRUCTION@VERIZON.NET

Section II: M/WBE Utilization Goal Calculation: Check the applicable box and complete subsection.

PRIME CONTRACTOR ADOPTING AGENCY M/WBE PARTICIPATION GOALS

<input checked="" type="checkbox"/> For Prime Contractors (including Qualified Joint Ventures and M/WBE firms) adopting Agency M/WBE Participation Goals.	Total Bid/Proposal Value	Agency Total Participation Goals (Line 1, Page 1)		Calculated M/WBE Participation Amount
Calculate the total dollar value of your total bid that you agree will be awarded to M/WBE subcontractors for services and/or credited to an M/WBE prime contractor or Qualified Joint Venture. Please review the Notice to Prospective Contractors for more information on how to obtain credit for M/WBE participation.	$\$ 7,586,047$	$70\% \quad 4\%$	$=$	$\$ 303,441$ Line 2

PRIME CONTRACTOR OBTAINED PARTIAL WAIVER APPROVAL: ADOPTING MODIFIED M/WBE PARTICIPATION GOALS

<input type="checkbox"/> For Prime Contractors (including Qualified Joint Ventures and M/WBE firms) adopting Modified M/WBE Participation Goals.	Total Bid/Proposal Value	Adjusted Participation Goal (From Partial Waiver)		Calculated M/WBE Participation Amount
Calculate the total dollar value of your total bid that you agree will be awarded to M/WBE subcontractors for services and/or credited to an M/WBE prime contractor or Qualified Joint Venture. Please review the Notice to Prospective Contractors for more information on how to obtain credit for M/WBE participation.	$\$$	X	$=$	$\$$ Line 3

Section III: M/WBE Utilization Plan: How Proposer/Bidder Will Fulfill M/WBE Participation Goals. Please review the Notice to Prospective Contractors for more information on how to obtain credit for M/WBE participation. Check applicable box. The Proposer or Bidder will fulfill the M/WBE Participation Goals:

As an M/WBE Prime Contractor that will self-perform and/or subcontract to other M/WBE firms a portion of the contract the value of which is at least the amount located on Lines 2 or 3 above, as applicable. The value of any work subcontracted to non-M/WBE firms will not be credited towards fulfillment of M/WBE Participation Goals. Please check all that apply to Prime Contractor:

MBE WBE

As a Qualified Joint Venture with an M/WBE partner, in which the value of the M/WBE partner's participation and/or the value of any work subcontracted to other M/WBE firms is at least the amount located on Lines 2 or 3 above, as applicable. The value of any work subcontracted to non M/WBE firms will not be credited towards fulfillment of M/WBE Participation Goals.

As a non M/WBE Prime Contractor that will enter into subcontracts with M/WBE firms the value of which is at least the amount located on Lines 2 or 3 above, as applicable.

Section IV: General Contract Information

What is the expected percentage of the total contract dollar value that you expect to award in subcontracts for services, regardless of M/WBE status? % 5.73

Enter brief description of the type(s) and dollar value of subcontracts for all/any services you plan on subcontracting if awarded this contract. For each item, indicate whether the work is designated for participation by MBEs and/or WBEs and the time frame in which such work is scheduled to begin and end. Use additional sheets if necessary.

8/2020 - 8/2021



- | | | | |
|-----|-------------------|-----|---------|
| 1. | TRUCKING SERVICES | WBE | 325,000 |
| 2. | SEWER T.V. | WBE | 60,000 |
| 3. | PHOTOGRAPHY | | 50,000 |
| 4. | | | |
| 5. | | | |
| 6. | | | |
| 7. | | | |
| 8. | | | |
| 9. | | | |
| 10. | | | |
| 11. | | | |
| 12. | | | |
| 13. | | | |
| 14. | | | |
| 15. | | | |
| 16. | | | |
| 17. | | | |

✓ Scopes of Subcontract Work

JA
12/9/19

Section V: Vendor Certification and Required Affirmations

I hereby:

- 1) acknowledge my understanding of the M/WBE participation requirements as set forth herein and the pertinent provisions of Section 6-129 of the Administrative Code of the City of New York ("Section 6-129"), and the rules promulgated thereunder;
- 2) affirm that the information supplied in support of this M/WBE Utilization Plan is true and correct;
- 3) agree, if awarded this Contract, to comply with the M/WBE participation requirements of this Contract, the pertinent provisions of Section 6-129, and the rules promulgated thereunder, all of which shall be deemed to be material terms of this Contract;
- 4) agree and affirm that it is a material term of this Contract that the Vendor will award the total dollar value of the M/WBE Participation Goals to certified MBEs and/or WBEs, unless a full waiver is obtained or such goals are modified by the Agency; and
- 5) agree and affirm, if awarded this Contract, to make all reasonable, good faith efforts to meet the M/WBE Participation Goals, or if a partial waiver is obtained or such goals are modified by the Agency, to meet the modified Participation Goals by soliciting and obtaining the participation of certified MBE and/or WBE firms.

✓ Signature	<u><i>Domenick Cipollone</i></u>	Date	<u>12-5-19</u>
Print Name	<u>DOMENICK CIPOLLONE</u>	Title	<u>PRESIDENT</u>

Contract Overview

Tax ID # _____ FMS Vendor ID # _____

Business Name _____

Contact Name _____ Telephone # _____ Email _____

Type of Procurement Competitive Sealed Bids Bid/Response Due Date _____
 Other

APT E-PIN # (for this procurement): _____ Contracting Agency: _____

MWBE Participation Goals as described in bid/solicitation documents

_____ % Agency MWBE Participation Goal

Proposed MWBE Participation Goal as anticipated by vendor seeking waiver

_____ % of the total contract value anticipated in good faith by the bidder/proposer to be subcontracted for services and/or credited to an MWBE Prime Contractor or Qualified Joint Venture.

Basis for Waiver Request: Check appropriate box & explain in detail below (attach additional pages if needed)

Vendor does not subcontract services, and has the capacity and good faith intention to perform all such work itself with its own employees.

Vendor subcontracts *some* of this type of work but at a *lower* % than bid/solicitation describes, and has the capacity and good faith intention to do so on this contract. (Attach subcontracting plan outlining services that the vendor will self-perform and subcontract to other vendors or consultants.)

Vendor has other legitimate business reasons for proposing the MWBE Participation Goal above. Explain under separate cover.

References
 List 3 most recent contracts performed for NYC agencies (if any). Include information for each subcontract awarded in performance of such contracts. Add more pages if necessary.

CONTRACT NO.	AGENCY	DATE COMPLETED
Total Contract Amount \$ _____	Total Amount Subcontracted \$ _____	
Item of Work Subcontracted and Value of subcontract _____	Item of Work Subcontracted and Value of subcontract _____	Item of Work Subcontracted and Value of subcontract _____
CONTRACT NO. _____	AGENCY _____	DATE COMPLETED _____
Total Contract Amount \$ _____	Total Amount Subcontracted \$ _____	
Item of Work Subcontracted and Value of subcontract _____	Item of Work Subcontracted and Value of subcontract _____	Item of Work Subcontracted and Value of subcontract _____
CONTRACT NO. _____	AGENCY _____	DATE COMPLETED _____
Total Contract Amount \$ _____	Total Amount Subcontracted \$ _____	
Item of Work Subcontracted and Value of subcontract _____	Item of Work Subcontracted and Value of subcontract _____	Item of Work Subcontracted and Value of subcontract _____

Tax ID #: _____

APT E-PIN #: 85020B0005

List 3 most recent contracts performed for other entities. Include information for each subcontract awarded in performance of such contracts. Add more pages if necessary.

(Complete ONLY if vendor has performed fewer than 3 New York City contracts.)

TYPE OF Contract	ENTITY	DATE COMPLETED
Manager at entity that hired vendor (Name/Phone No./Email)		
Total Contract Amount \$	Total Amount Subcontracted \$	
Type of Work Subcontracted		

TYPE OF Contract	AGENCY/ ENTITY	DATE COMPLETED
Manager at agency/entity that hired vendor (Name/Phone No./Email)		
Total Contract Amount \$	Total Amount Subcontracted \$	
Item of Work Subcontracted and Value of subcontract	Item of Work Subcontracted and Value of subcontract	Item of Work Subcontracted and Value of subcontract

TYPE OF Contract	AGENCY/ ENTITY	DATE COMPLETED
Manager at entity that hired vendor (Name/Phone No./Email)		
Total Contract Amount \$	Total Amount Subcontracted \$	
Item of Work Subcontracted and Value of subcontract	Item of Work Subcontracted and Value of subcontract	Item of Work Subcontracted and Value of subcontract

VENDOR CERTIFICATION: I hereby affirm that the information supplied in support of this waiver request is true and correct, and that this request is made in good faith.

Signature: _____ **Date:** _____
Print Name: _____ **Title:** _____

Shaded area below is for agency completion only

AGENCY CHIEF CONTRACTING OFFICER APPROVAL
Signature: _____ **Date:** _____
CITY CHIEF PROCUREMENT OFFICER APPROVAL
Signature: _____ **Date:** _____

Waiver Determination
 Full Waiver Approved:
 Waiver Denied:
 Partial Waiver Approved:
 Revised Participation Goal: _____ %

APPRENTICESHIP PROGRAM REQUIREMENTS

Bidders are advised that the Apprenticeship Program Requirements set forth below apply to each contract for which a "X" is indicated before the word "Yes". Compliance with these requirements will be determined solely by the City.

 X YES NO

(1) Apprenticeship Program Requirements

Notice to Bidders: Please be advised that, pursuant to the authority granted to the City under Labor Law Section 816-b, the Department of Design and Construction hereby requires that the contractor awarded a contract as a result of this Invitation for Bids, and any of its subcontractors with subcontracts worth two million dollars or over, have, prior to entering into such contract or subcontract, apprenticeship agreements appropriate for the type and scope of work to be performed that have been registered with, and approved by, the New York State Commissioner of Labor. In addition, the contractor and its subcontractors will be required to show that such apprenticeship program/s have successfully passed the two year Probation period following the initial registration date of such program/s with the New York State Department of Labor.

The failure to prove, upon request, that these requirements have been met shall result in the contract not being awarded to the contractor or the subcontract not being approved.

Please be further advised that, pursuant to Labor Law Section 220, the allowable ratio of apprentices to journeypersons in any craft classification shall not be greater than the ratio permitted to the contractor as to its workforce on any job under the registered apprenticeship program.

(2) Apprenticeship Program Questionnaire

The bidder must submit a completed and signed Apprenticeship Program Questionnaire. The Questionnaire is set forth on the following pages of the Bid Booklet.

APPRENTICESHIP PROGRAM QUESTIONNAIRE ("APQ")

Bidder Name: ADC CONSTRUCTION, LLC

Project ID Number: SEQBN11

The Bidder MUST complete, sign and submit this Apprenticeship Program Questionnaire with its bid.

1. Does the bidder have any Apprenticeship Program agreement(s) appropriate for the type and scope of work to be performed? (Note: Participation may be by either direct sponsorship or through collective bargaining agreement(s).)

YES NO

2. Has/have the bidder's Apprenticeship Program agreement(s) been registered with, and approved by the New York State Commissioner of Labor ("NYSDOL Commissioner")?

YES NO

3. Has/have the bidder's Apprenticeship Program successfully passed the two-year Probation period following its initial registration with the New York State Department of Labor ("NYSDOL")?

YES NO

If the answers to Questions 1, 2, and 3 are "Yes". The bidder shall, in the space below (and/or attached herewith where applicable), provide the contact information for such Apprenticeship Program(s) as well as information demonstrating that such Apprenticeship Program(s) have passed the two-year Probation period following its initial registration with the NYSDOL. (The bidder may attach additional pages if necessary).

- **Where the bidder directly sponsors any such apprenticeship Program(s), the bidder shall provide the following:**
 - The trade classification(s) covered by such program(s), and the date(s) such program(s) was/were approved by the NYSDOL Commissioner; and/or
 - A copy of a letter(s) from the NYSDOL, on NYSDOL's letterhead, executed by an official thereof, which verifies/verify the trade classification(s) covered by such program(s), and the date(s) such program(s) was/were approved by the NYSDOL Commissioner and the Active status of such program(s).

- **Where the bidder participates in any such Apprenticeship Program(s) through its membership in an employer organization(s) that directly sponsors such program(s) or where the employer association(s) participates in such program(s) through collective bargaining, the bidder shall provide the following:**
 - The contact information for the employer organization(s), and the apprenticeable trade(s) covered pursuant to the bidder's affiliation therewith, and the date such program(s) was/were approved by the NYSDOL Commissioner; or
 - A letter(s) from such employer organization(s), on letterhead of such organization(s), executed by an officer, delegate or official thereof, which verifies/verify the trade classification(s) covered by such program(s) was/were approved by the NYSDOL Commissioner, and that the bidder is both a member in good standing of the identified employer organization and is subject to the provisions of the Apprenticeship Program agreement(s) sponsored thereby.

APPRENTICESHIP PROGRAM QUESTIONNAIRE ("APQ")

- Where the bidder participates in any such Apprenticeship Programs through collective bargaining agreements, the bidder shall provide the following:
 - The contact information for such collective bargaining entity(ies) and the apprenticeable trade(s) covered pursuant to the bidder's affiliation therewith;
 - A letter(s) from such collective bargaining entity(ies), on letterhead of such entity(ies), executed by an officer, delegate or official thereof, which verifies/verify the bidder's status as a signatory/participant in good standing to such collective bargaining entity(ies) Apprenticeship Program Agreements.

ADMINISTERED THRU LOCAL UNIONS 6010, 731

Bidder: ADC CONSTRUCTION, LLC

By: *Joseph C. [Signature]* Title: PRESIDENT
(Signature of Partner or Corporate Officer)

Date: 12-5-19

**BUILDING, CONCRETE
EXCAVATING &
COMMON LABORERS' UNION
LOCAL No. 731
of
GREATER NEW YORK
LONG ISLAND AND VICINITY
of the
LABORERS' INTERNATIONAL
UNION OF NORTH AMERICA**

INDEPENDENT AGREEMENT

JULY 1, 2016 to APRIL 30, 2022

INDEX

ARTICLE I - Purposes - Declaration of Principles..... 1

Section 1 - Purposes 1

Section 2 - Declaration of Principles 2

ARTICLE II - Jurisdiction..... 3

ARTICLE III - Union Security - Union Visitation..... 5

Section 1 - Union Security 5

Section 2 - Recognition 6

Section 3 - Pre-Job Conference 6

Section 4 - Subcontractors and Business Entities 7

Section 5 - Interrelated Business Entities 9

Section 6 - Shop Stewards 10

Section 7 - General Foreman and Foreman of Laborers 11

Section 8 - Apprentice (s) 12

Section 9 - Union Visitation 13

ARTICLE IV - Disputes..... 13

Section 1 - No Lockout - Strike - Work Stoppage 13

Section 2 - Procedures of Grievance - Arbitration 14

Section 3 - Finality of Decision 17

Section 4 - Status Quo 17

Section 5 - Expenses 17

ARTICLE V - Jurisdictional Disputes..... 18

Section 1 - No Work Stoppage 18

Section 2 - Resolution of Jurisdictional Disputes 18

ARTICLE VI - Work Jurisdiction.....	20
A. Excavation and Foundation Work for Buildings	20
B. Landscaping in Connection with Building Projects	26
C. Heavy Construction and Engineering Work	29
D. Landscaping in Connection with Heavy Construction and Engineering Work.....	39
 ARTICLE VII - Wages and Conditions.....	 41
Section 1 - Hours of Work	41
Section 2 - Shifts	42
Section 3 - Overtime and Holidays	43
Section 4 - Wages	46
Section 4.1 - Payment of Wages by Check	47
Section 5 - Conditions	48
Section 6 - Use of Intoxicant or Illegal Drug	49
Section 7 - Drug Testing Clause	50
Section 8 - Paid Sick Leave	50
Section 9 - Paid Family Leave	50
 ARTICLE VIII.....	 51
Section 1 - Welfare Fund	51
Section 2 - Pension Fund	53
Section 3 - Annuity Fund	54
Section 4 - LIUNA Local 731 Training Fund	55
Section 5(a) - Union Membership Supplemental	57
Section 5(b) - Political Action Committee	58
Section 5(c) - Duties of Employer To Funds With Respect To New Hires	59
Section 6 - Heavy Construction Industry Fund	59

Section 7(a) - Summary of Hourly Wages, Fringes etc., for Laborers Other than Foremen.....	61
Section 7(b) - Summary of Hourly Wages, Fringes, etc., for Foremen.....	61
Section 7(c) - Checkoffs	61
Section 7(d) - New York State Laborers-Employers Cooperation and Education Trust.....	62
Section 8(a) - Bonding	63
Section 8(b) - Cash Alternative to Bond	64
Section 9 - Method of Payment.....	65
Section 10 - Records - Reports - Liability	66
ARTICLE IX - Work Stoppage for Default in Payment of Wage and/or Welfare, Pension and Annuity Payments	
Section 1	70
Section 2 - Removal of Workers Upon Default	71
Section 3 - Arbitration	71
Section 4	75
ARTICLE X - Legality.....	
Section 1	75
Section 2	76
ARTICLE XI - Notices.....	76
ARTICLE XII - Execution of Agreement.....	77
ARTICLE XIII - Term of Agreement.....	77
ARTICLE XIV - Intent of Agreement.....	77

AGREEMENT made this day of

Between

Of

(hereinafter referred to as "Employer")

and

BUILDING, CONCRETE, EXCAVATING & COMMON LABORERS UNION, LOCAL NO. 731 of
GREATER NEW YORK, LONG ISLAND AND VICINITY of the LABORERS' INTERNATIONAL
UNION OF NORTH AMERICA, 3411 35th Avenue Astoria, New York 11106
(hereinafter sometimes called "Local 731" and sometimes "Union").

ARTICLE I

Purposes - Declaration of Principles

Section 1 - Purposes

The purposes for which this collective bargaining agreement (this "Agreement") is entered into are as follows:

- (a) To prevent strikes and lockouts;
- (b) To facilitate peaceful adjustments of grievances and disputes between the Employer, Employee and Union;
- (c) To prevent waste, unnecessary and avoidable delays, which result in unnecessary costs and expense to the Employer and Union, and the loss of wages to the Employee;
- (d) To enable the Employer to secure at all times sufficient forces of skilled workers;
- (e) To provide as far as possible for the continuous employment of labor;
- (f) To provide that employment shall be in accordance with conditions and at wages herein agreed upon;

- (g) To bring about stable conditions in the Construction Industry;
- (h) To keep costs of work in the Industry as low as possible consistent with fair wages and proper working conditions, as provided for hereunder;
- (i) To establish the necessary procedure for amicable adjustment of all disputes that may arise.

Section 2 - Declaration of Principles

The parties to this Agreement believe that a Uniform Agreement, if adopted by all employers and all unions engaged in the Construction Industry, would further the interests of the Industry, and further believe that such a Uniform Agreement should contain the following Principles, upon which the parties hereby agree:

1. That none of the parties hereto, nor any of the representatives of any of them, shall discriminate in any manner, against any Laborer, General Foreman, Foreman, Steward or other individual by reason of union activity, as provided by law, race, color, creed, religion, national origin, age, sex, union membership or non-membership, marital status, disability, citizenship status, or sexual orientation.
2. That there shall be no limitation as to the amount of work a person shall perform during the working day, it being understood that workers shall perform a fair and honest day's work;
3. That there shall be no restriction on the use of any raw or manufactured materials, except prison made;
4. That there shall be no restriction on the use of machinery, tools, or appliances;

5. That no person shall have the right to interfere with workers during working hours;
6. That workers are at liberty to work for whomever they see fit, but that they are entitled to and shall receive the wages agreed upon;
7. That the Employers are at liberty:
 - (a) except as provided in subparagraph "1" above, to employ and discharge whomever they see fit,
 - (b) except as provided in subparagraph "1" above, to reject any job applicant referred by Local 731, and
 - (c) to be the sole judge, at all times, as to the work to be performed and whether such work performed by any workers or laborers represented by Local 731 and employed by the Employers, is or is not satisfactory.
8. Any past practice or custom that is a violation of the terms of this Agreement shall not be deemed a precedent and shall not constitute a waiver of the terms of this Agreement as regards to any such past practice or custom.

ARTICLE II

Jurisdiction

This Agreement covers work done by the Employer engaged in NEW YORK CITY and VICINITY on EXCAVATION AND FOUNDATION WORK FOR BUILDINGS, LANDSCAPING WORK and/or HEAVY CONSTRUCTION WORK, as those terms are hereinafter defined.

If any of the Employers engage in any class of work not embodied in EXCAVATION AND FOUNDATION WORK FOR BUILDINGS, LANDSCAPING and/or HEAVY CONSTRUCTION WORK, as those terms are hereinafter defined, they shall

comply with all of the Union conditions then existing in that class of work.

Heavy Construction Work is hereby defined as including but not limited to, new construction, i.e. building and foundation construction below street level, or the inspection, rehabilitation or expansion of an existing structure or facility involving any aspect of subsurface construction or excavation, all deconstruction or demolition work, all construction from excavation through final completion of: engineered structures, parking garages, mass transit facilities including but not limited to bus depots, ventilation plants, maintenance shops, transit yards, stations, tunnels, railway lines and work along railway rights of way, highways, roads, streets, bridges, piers, wharves and bulkheads, marine transfer stations, airport runways, access roads, airline terminals, water and wastewater conveyances, including but not limited to tunnels, and associated facilities including gatehouses, pumphouses, valve chambers, and water and water treatment plants, power plants, power generating stations, electrical substations, and pipelines: all excavation and sitework, including but not limited to all installation, relocation or removal of utilities, all drainage, landscaping, curbsetting, and paving: removal of hazardous materials as it pertains to heavy construction projects; and any construction commonly associated with "public works," "infrastructure" or "heavy civil" construction, exclusive of the erection of building superstructures, since this latter work is agreed to be a separate and distinct branch of the construction industry.

The Employer agrees to preserve traditional craft jurisdiction as set forth in the various collective bargaining agreements of the Local Unions affiliated with LIUNA. This recognition is made in an effort to preserve

work opportunities for Members of LIUNA Local Unions and for Employers to oppose any efforts by any and all other unions which may seek to undermine the jurisdiction of the Laborers.

ARTICLE III

Union Security - Union Visitation

Section 1 - Union Security

(a) All employees who are members of the Union at the time of signing of this Agreement shall continue membership in the Union. The Union shall have the right to require all other employees to become members of the Union within seven (7) days following the beginning of employment or the effective date of this Agreement, whichever is later, and must maintain their membership in good standing in the Union as a condition of continued employment. If the provisions for Union Security clauses are modified by Congress during the terms of this Agreement, this clause will automatically become modified to conform to such changes.

(b) Employees covered by this Agreement shall not refuse to work with persons who, after seven (7) days employment, have complied with the Union Security provisions of this Agreement. However, employees covered by this Agreement are not required to work for any contractor who does not comply with the Union Security provisions of this Agreement. It is understood that additional Laborers secured by the employer shall be eligible for and shall comply with requirements of Union membership as set forth herein.

(c) If the Employer covered by this collective bargaining agreement or any such principal owner or principal forms or acquires by purchase, merger or otherwise, an interest, whether by ownership, stock, equitable or managerial, in another company, corporation, partnership, or any other business entity, including joint venture and sole

proprietorship, performing bargaining unit work within this jurisdiction, this collective bargaining agreement shall cover such other operation.

Section 2 - Recognition

The Employer hereby agrees to recognize Laborers Local 731, affiliated with the Laborers International Union of North America, as the National Labor Relations Act Section 9(a) representative of a group of its employees as follows:

The Union has submitted authorization cards showing that a majority of the Employer's employees employed performing Laborers work have expressed a desire to have the Union be their exclusive bargaining representative.

The Employer has examined the authorization cards and is satisfied that the Union has majority support among these employees.

Therefore, the Employer agrees to recognize the Union status under Section 9(a) of the National Labor Relations Act as the exclusive bargaining agent for its employees performing Laborers work in the bargaining unit as defined in the current collective bargaining agreement between the Union and the Employer.

Section 3 - Pre-Job Conference

Each Employer covered by this Agreement shall be required to conduct a Pre-Job Conference with the Union prior to the commencement of any job. The purpose of the Pre-Job Conference is to settle any issues regarding the interpretation of this Agreement, and the retention of any known subcontractor(s) to perform bargaining unit work. At the pre-job conference any known jurisdictional disputes should be discussed prior to commencement of work. Should any Employer fail to conduct a Pre-Job Conference before the commencement of a job, that Employer will be presumed to have knowledge of all terms and conditions of this Agreement.

Section 4 - Subcontractors and Business Entities

(a) The Employer shall not enter into a contract with any other person or entity¹, to perform bargaining unit work within in territorial jurisdiction of the Union, unless such other person or entity has signed a collective bargaining agreement with the Union on work traditionally performed by members of Local 731 or is a member of an Association which has signed a collective bargaining agreement with the Union and has authorized such Association to negotiate and execute a collective bargaining agreement on its behalf.

(b) The terms, covenants and conditions of this Agreement shall be binding upon all subcontractors at the site to whom any of the Employers may have re-subcontracted all or part of any contract entered into by said Employer. Each of the Employers shall notify Local 731, in writing, thirty (30) days prior to the start of work on any job or project that a subcontract necessitating employment of the Employees covered by this Agreement has been let. Included in said notification shall be the name and address of each said subcontractor as well as the location of said job or project. If a subcontractor is more than seven (7) days delinquent in payment of wages or thirty (30) days delinquent in require payments to the Benefits Funds, and said delinquency is attributable to work performed by the subcontractor for the Employer, the Employer shall be notified, in writing, by the Funds, by certified mail, return receipt requested, by facsimile transmission or by overnight delivery, that the subcontractor is delinquent

¹**Entity defined as:** partnership, limited liability company, firm, company, corporation or any other business entity including any joint venture or sole proprietorship which now or hereafter exist.

In the event that the Employer is in possession of certified payroll reports filed by the subcontractor, it shall promptly provide copies of same upon request of the Benefits Funds.

If the Employer is notified, in writing, that the subcontractor is still delinquent fifteen (15) days after the Employer has been notified, in writing, of any such delinquency, by the Union or by the Benefits Funds, the Employer shall make payment of the full amount of such delinquency within ten (10) days of receipt of such second notice.

If payment from the employer on behalf of its subcontractor is not received within such ten (10) day period, the Employer shall be responsible for payment of interest at 10% per annum from the date of such second notice and 10% liquidated damages, and be subject to the arbitration provisions of this agreement provided in Article IX, Section 3.

(c) Each of the Employers undertakes and agrees that in addition to the surety company bond to be provided by each of them pursuant to the terms and conditions of this Agreement, each such subcontractor shall also provide for itself the surety company bond or cash alternative required of each of them under this Agreement.

If any such subcontractor fails to provide said surety company bond to Local 731, Welfare Fund, Pension Fund, Annuity Fund and/or the LIUNA Training Fund within five (5) days after Local 731 or any or all of said Funds makes written demand therefore of said subcontractor and the Employer of said subcontractor, said Employer shall then forthwith (a) provide and deliver to Local 731, Welfare Fund, Pension Fund, Annuity Fund and Training Fund, a surety company bond duly executed by said subcontractor, as Principal, and the surety company writing such bond, as Surety, or (b) the unconditional undertaking and guaranty of said

Employer in favor of Local 731, Welfare Fund, Pension Fund, Annuity Fund and Training Fund wherein and whereby the Employer undertakes and guarantees to make prompt payment, when due, to the Welfare Fund, Pension Fund, Annuity Fund and Training Fund of all contributions required to be paid by said subcontractor to said Welfare Fund, Pension Fund, Annuity Fund and Training Fund, with interest thereon, liquidated damages, reasonable attorney's fees and the costs of the arbitration. If and when any of the Employers acquires a financial interest in any firm or company engaged in the work set forth in Article VI of this Agreement, said firm or company shall be automatically bound by the terms and conditions of this Agreement in the same manner as if it has been a signatory hereto.

Section 5 - Interrelated Business Entities

In order to protect and preserve for Local No. 731 all work traditionally performed by it, and in order to protect and preserve such work under this Agreement, it is hereby agreed as follows: If and when the Employer shall perform any work of the type covered by this Agreement, under its own name or under the name of another, as a person, company, corporation, partnership, or any other business entity, including any joint venture and/or sole proprietorship, wherein the Employer exercises either directly or indirectly any significant degree of ownership, management or control, the terms and conditions of this Agreement shall be applicable to all such work: (a) where the two (2) enterprises have substantially identical management, business purpose, operation, equipment, customers, supervision and/or ownership; and (b) where there exists between the Employer and such other business entity, interrelation of operations, common management, centralized control of labor relations and/or common ownership. In determining the existence of the above criteria, the presence of the requisite commonality of control

at any level of management shall be deemed to satisfy the criteria. Should the Employer establish or maintain such other entity within the meaning of this Section, the Employer is under an affirmative obligation to notify the Union of the existence and nature of the work performed by such other entity and the nature and extent of its relationship to the Employer.

Section 6 - Shop Stewards

All Employers who do the work as set forth in this Agreement shall employ Laborers exclusively to perform such work and shall employ Laborer Shop Stewards. Where more than one Employer does Laborer work on a project, each Employer shall employ Laborers exclusively to perform the work and each Employer shall employ Laborer Shop Stewards. Where Laborers are employed on a project, the Business Manager of Local 731 shall place a shop steward on the first shift who shall be the second laborer on the job. A steward for the second and/or third shift may be placed by the Union Business Manager. The second and/or third shift steward will be a working steward and will be laid off when the shift ends

In the event an Employer circumvents this requirement, the Employer will be required to hire an additional Laborer who will be designated as Shop Steward. Additionally, the Steward shall have the first right of refusal on overtime. The Steward shall see to it that the classification of work as defined herein is observed and that the Employers are complying with the terms of this Agreement. The Steward shall be afforded the opportunity to perform his duties, which include, but are not limited to, checking of subcontractors, new hires, books, and payment of correct wage rates, and the receipt of laborers' reports of

grievances. He shall be responsible for the maintenance of a complete monthly Steward Report. He shall retain possession of the key to the tool house and see to it that it is open in ample time at starting time and securely locked at quitting time. Any work to be performed in or at a jobsite yard, including and not limited to the storeroom, shall be performed by the shop steward. He shall perform these duties as Shop Steward with the least possible inconvenience to his Employer. He is to work as a Laborer and not use his position as Shop Steward to avoid performance of his duties as a Laborer. If the Shop Steward is discharged, the contractor must immediately notify the Union and a grievance hearing as described in Article IV Section 2(a) shall be held within three (3) workdays. If it is determined that the Shop steward was improperly discharged, he shall be reinstated and paid for lost time and fringe benefits for such lost time shall be paid to the Excavators Union Local 731 Benefit Funds on his/her behalf. If the grievance hearing cannot reach a decision, the matter shall be referred to expedited arbitration. The Shop Steward is to work up to completion of the job and shall be the last working laborer to be discharged exclusive of the Foreman.

Section 7 - General Foreman and Foreman of Laborers

(a) **General Foreman of Laborers.** The requirement of a General Foreman may be discussed at a pre-job conference between the Union and the Employer. The wages for the General Foreman shall be negotiated between the proposed General Foreman and the Employer.

(b) **Foreman of Laborers.** The foreman shall be a representative of the Employer and shall be in direct charge of the Laborers on the job. All foremen shall be paid a weekly salary which shall not be less than

\$2.50 per hour above the prescribed rate for Laborers in this Agreement.

Laborers shall not be required to take craft supervision from other union foremen, except where agreed upon at a pre-job conference.

At commencement of employment, a Foreman shall be paid for days actually worked in the calendar week. At the termination of employment, a Foreman will be paid for days actually worked in the calendar week. During the course of continuous employment on a project, said Foreman shall be paid on a weekly basis, and shall not receive holiday pay as an addition to his weekly pay unless worked. If worked, said Foreman shall receive one day's pay at the straight time rate. If a Foreman works over eight (8) hours per day, or forty (40) hours per week, he shall be entitled to overtime. If a "gang" is laid off prior to job completion, the Foreman shall be entitled to forty (40) hours of pay for the week. The minimum rates of wages for Foremen for one week shall be as follows:

*ONE THOUSAND, SEVEN HUNDRED AND FORTY DOLLARS, AND NO CENTS.
(\$1,740.00), FROM JULY 1, 2016 TO AND INCLUDING JUNE 30,
2017. (\$43.50 per hour)

*Allocation of subsequent yearly increases will be determined by the Union prior to July 1 of each collective bargaining year.

Section 8 - Apprentice (s)

The ratio of apprentices to journeymen shall be 1:8. At the Employer's discretion, the ratio may be 1:4 on entry level classifications for private work (i.e. foundation and non-city, state, or federally funded projects). Apprentices shall initially be paid at 50% of the journeyman's wages and will be adjusted as follows:

1000 hours worked:	60% of journeyman's wage
2000 hours worked:	75% of journeyman's wage
3000 hours worked:	90% of journeyman's wage
4000 hours worked:	100% of journeyman's wage

In order to qualify as an apprentice, a laborer must be enrolled in the Local 731 Apprenticeship Training Program. Under no circumstances may a laborer be listed as an apprentice unless such prerequisite training has been completed. Implementation of mandatory apprenticeship will be discussed during the term of this agreement. Apprentices are solely responsible to provide the Employer with documentation confirming their status in the apprentice program and the hours currently worked as an apprentice.

Section 9 - Union Visitation

The Business Agent, Business Manager or other designated representative shall have the right to visit and go upon the Employer's Union jobs during working hours. He shall not be interfered with when making such visits nor shall he hinder or interfere with the progress of the work.

ARTICLE IV

Disputes

Section 1 - No Lockout - Strike - Work Stoppage

Except as otherwise provided for herein, the Union shall not order or sanction a strike against any Employer or Employers, who are parties to this Agreement, nor shall any Employer or Employers, acting jointly or severally, directly or indirectly lock out any laborers represented by the Union that are parties to this Agreement. The Union shall not be responsible for any unauthorized strike or its results.

When the laborers on any job are being paid less than the rate of wages prescribed in this Agreement, or prevailing wages are not being adhered to, the Union shall be entitled to withdraw labor without notice. If the Employer is in arrears on monies payable to the Trust Funds as

prescribed in this Agreement, as hereinafter provided, the Union shall give three (3) working days written notice to the Employer and the Union shall be entitled to withdraw the laborers from such job upon expiration of the three working days written notice.

The Union representative in consultation with the Employer representative may declare a portion of a job-site, or a job-site, a threat to the health, safety and welfare of the Employees covered by this Agreement. The work shall be curtailed until the situation is resolved.

However, none of the provisions of this Article shall be construed so as to prevent Local 731, from exercising its inherent right, herein and hereby recognized, to remove its members, or cause its members to be removed, from any job under Local 731's jurisdiction upon three (3) working days written notice delivered in person, or in the manner specified in Article XI, hereinafter, if or when any of the Employers (a) default in making payment when due of any wages required to be paid pursuant to Section 6 (b) of Article III hereinbefore and/or (to Article VII hereof) (b) default in making payment, when due, of any of the amounts of contributions required to be paid to the Excavators Union Local 731 Welfare Fund, the Excavators Union Local 731 Pension Fund, the Excavators Union Local 731 Annuity Fund and or LIUNA Local 731 Training Fund pursuant to Article VIII hereof, and/or (c) default in providing the surety company bond or the cash alternative required pursuant to Section (8) of Article VIII hereof.

Section 2 - Procedures of Grievance - Arbitration

Except as hereinbefore otherwise provided in the last sentence of Section 1 of this Article IV, and except as regards the wages required to be paid pursuant to the provisions of Article VII hereof and the collection of contributions required to be paid to the Trustees of

Excavators Union Local 731 Welfare Fund, Excavators Union Local 731 Pension Fund, Excavators Union Local 731 Annuity Fund and LIUNA Local 731 Training Fund pursuant to the provisions of Article VIII hereof, for the purpose of settling disputes between any of the Employers and Local 731 or any of the Employers and any of the workers covered by this Agreement as to any claims of violation of this Agreement or of any dispute that may arise in connection therewith or for construing the terms and provisions thereof, the following procedure is established:

- (a) The matter in dispute shall be immediately reported by the Employer involved or by Local 731 to the President of Local 731 who shall promptly arrange a meeting between said Employer and representatives of Local 731 in an effort to reach an amicable solution.
- (b) Should this fail to effect a resolution of the dispute, the Employer involved or Local 731 may serve upon the other party a demand for arbitration or a notice of intention to arbitrate, specifying the agreement pursuant to which arbitration is sought and the name and address of the party serving the notice, the name and address of an officer or agent thereof if such party is an association or corporation, and stating that unless the party served applies to stay the arbitration within twenty days after such service he shall thereafter be precluded from objecting that a valid agreement was not made or has not been complied with and from asserting in court the bar of a limitation of time. Such notice or demand shall be served in the same manner as a summons or by registered or certified mail, return receipt requested. An application to stay arbitration must be made by the party

served within twenty days after service upon him of the notice or demand, or he shall be so precluded. Notice of such application shall be served in the same manner as a summons or by registered or certified mail, return receipt requested. Service of the application may be made upon the adverse party or upon his attorney if the attorney's name appears on the demand for arbitration or the notice of intention to arbitrate. Service of the application by mail shall be timely if such application is posted within the prescribed period.

(c) Any grievance not resolved pursuant to (a) or (b) above, shall be submitted to arbitration before a single arbitrator. The arbitrator shall serve, in order, from a panel of two as follows:

- (1) Stephen F. O'Beirne Esq. 176 Washington Avenue, Clifton, New Jersey, 07011.
- (2) Thomas J. Hanrahan, Esq., P.O. Box 140, Glen Rock, New Jersey 07452-0140

All arbitrators selected as successors must be unanimously agreed upon by the parties. The two will serve to the end of this Agreement. If any arbitrator is not available to serve for any reason, the next one on the list shall serve. The arbitrator shall conduct a hearing in such a manner as he shall consider proper and shall serve as sole arbitrator of the dispute between the parties. After all the parties concerned have been notified in writing at least five (5) days prior to a hearing, the arbitrator shall have the right to conduct an ex parte hearing in the event of the failure of either party to be present at the time and place designated for the arbitration, and shall have the power to render a decision based on the testimony before him at such hearing. The costs of

arbitration, including the arbitrator's fee, shall be borne equally by the Employer and the Union. Service of any document or notice referred to above, or service of any notice required by law in connection with arbitration proceedings, may be made by registered or certified mail.

(d) Refusal to adhere to the decisions under any one of the provisions above shall allow the Union to withhold the services of its Laborers.

(e) This Article is not, in any manner, meant to prohibit or restrict the Union's right to strike or withhold services upon the expiration of this Agreement.

Section 3 - Finality of Decision

A decision made under any one of the above plans shall be final and binding upon all parties to the dispute. From the date the decision is made, it shall become part of this Agreement. Any decision and/or award may be confirmed, and judgment entered thereupon in any court of competent jurisdiction.

Section 4 - Status Quo

Until any decision shall have been reached, none of the parties to such dispute, the parties to this Agreement or the workers covered by this Agreement involved in such dispute, shall take any action of any character as to the complaint, statement or matter in dispute.

Section 5 - Expenses

The expenses and salary, if any, of the single arbitrator shall be equally shared by the parties to the dispute.

ARTICLE V

Jurisdictional Disputes

Section 1 - No Work Stoppage

Where a jurisdictional dispute arises, there shall be no stoppage of work by trades affiliated with the AFL-CIO. In the event of such jurisdictional dispute, the trade in possession of the work shall proceed with the job and the question in dispute shall be submitted by the disputing trades to the General Contractors Association.

Section 2 - Resolution of Jurisdictional Disputes

The Employers bound by this Agreement recognize the jurisdictional claims of the Laborers Local 731. The Employers and the Union agree that jurisdictional disputes on heavy construction projects shall be addressed in the following manner:

- a) The first action to resolve a dispute will be a work site discussion among the involved parties; the work site discussion should take place within 48 hours of the onset of the dispute. If the work site discussion results in a resolution of the issue, there shall be no further action taken by the involved parties.
- b) If work site discussions do not result in a satisfactory resolution of the issue, any of the involved parties (the Employer, Local 731, or the Union claiming Local 731's work) may request a meeting with the GCA to resolve the dispute. All work shall continue, and the assignment shall remain in place through the duration of the dispute and if necessary, arbitration process.

The request for the meeting must be filed in writing and must set forth the type of work being performed, the location and the nature of claim. The request must be sent to the Employer, the

involved unions and the GCA. Notices of disputes must be filed within seven (7) calendar days of the incident leading to the dispute. Immediately upon receipt of the dispute the GCA will schedule a meeting with the parties.

- c) At the meeting, the parties to the dispute shall be given full opportunity to present witnesses and/or documents supporting their position. The GCA will conduct the mediation to bring the dispute to resolution. The resolution of the dispute shall be documented and signed by all participants (i.e. the Union, the Employer and the GCA). The decision shall become a precedent for the assignment of future work.

If the mediation does not result in a satisfactory resolution or if the agreed upon decision is not implemented within 72 hours after the parties have been notified of the mediation decision, any party involved in the dispute may request that the dispute be brought to arbitration.

- d) The arbitration process will work in the following manner: The arbitrator shall be selected from a list of five that will be selected by the GCA and the GCA's signatory unions. The arbitrator chosen to hear a particular dispute shall be selected randomly from the list. The hearing shall be conducted in accordance with the procedures established by each arbitrator. The arbitrator's decision shall be final and binding upon the parties. The cost of arbitration, including the arbitrator's fee, shall be borne equally by the GCA and the party bringing the dispute to arbitration.

ARTICLE VI

Work Jurisdiction

This Agreement shall apply to the employment of laborers on:

- A. EXCAVATION AND FOUNDATION WORK FOR BUILDINGS** inside and outside property lines, or first connection outside of the building penetration, and all work in conjunction with all jurisdiction within this category and all other categories of this agreement, including, but not limited to:
1. Building operations below the curb line and below the building superstructure in connection with excavation and foundation work for buildings;
 2. All labor used in excavation of earth and rock in footings, piers and other holes, pits, trenches, sewers (inside of buildings and the house connections in the street);
 3. Grading and excavation of sidewalks;
 4. All backfilling in connection with buildings;
 5. The sealing of rock with concrete on piers, footings, pits and foundations;
 6. All labor used in pouring, sandblasting, scarifying, bush hammering, dry packing and guniting of concrete, prepack concrete, pumpcrete, colcrete or other similar processes for footings, piers, piles, pile caps;
 7. Retaining walls on foundations, underpinning and work in connection therewith;
 8. All laborers' work in conjunction with vibroflotation;
 9. The shoveling and packing of sand in sand piles;
 10. The placing of concrete in all types of piles;

11. All laborers' work in connection with chemical soil solidification, slurry walls, bentonite, mud mixing and all other methods of soil solidification;
12. All laborers' work in connection with: guniting and pouring of concrete, prepack concrete, pumpcrete, colcrete and/or similar processes for all underground tunnels and concrete cradles for sewers and all other utilities in building areas;
13. The application of epoxy for protection on all pre-cast and poured concrete as well as for protection from the elements;
14. Surface preparation of caissons and related structures;
- 15a. Handling, cleaning and fastening of all chutes, pipes and elephant trunks used in the placing of concrete as well as setting up and cleaning of conveyor belts used in the placing of concrete;
- 15b. Assisting in the removal of and removing all wood, steel and other forms for concrete;
- 15c. Cleaning and oiling of all wood, steel and other forms for concrete;
- 15d. Concrete specialist work;
16. Digging trenches for duct lines;
17. Digging holes for fence posts and poles inside and outside of buildings;
18. Breaking down of old foundation walls either with sledge hammer, pick or iron bar and removal of materials by loading truck or other means as well as other loading and unloading of materials;
19. Tending of other trades;

20. Distribution and handling of gasoline, propane gas and other fuel for heaters, etc., as well as handling and hooking up of all equipment used in connection therewith;
21. Installing, handling, loading, unloading, placing, hooking, unhooking, lowering into ditch, aligning, leveling and jointing of corrugated pipe, concrete pipe, plastic pipe, fiberglass pipe, and other nonmetallic pipe, pipe liners, cast iron pipe, steel pipe, ductile concrete lined pipe and trenchless pipe;
22. In connection with transportation lines, all laborers' work for the clearance of right-of-way preparatory to the installation of the pipe line, the demolition and removal of fences, the digging and trimming of trenches and ditches for pipe lines, work in connection with bending of pipe except the mechanical work involved; laborers' work in connection with the distribution of pipe and skids and placing of said skids and pipe over the trench, the cleaning, scaling, etc., of the pipe; all laborers' work in connection with the lineup crew, the cleaning, wrapping and doping of pipe before lowering after the welding of joints has been made, the cleaning, wrapping and doping of the pipe in all yards;
23. The work in connection with the lowering of the pipe and the removal of the skids;
24. The work in connection with the backfilling of trenches after the pipe has been laid;
25. All work in connection with the cleanup after the pipe has been laid and the trenches backfilled;

26. Demolition, take-up and reconditioning of old pipe and pipelining of all kinds;
27. Laborers' work on barges and floating equipment, and all other general and miscellaneous laborers' work in connection with the entire operation falling within the jurisdiction of Local 731;
- 28a. Digging for sidewalks, including that for lighting posts, fence posts, duct lines and precast concrete boxes, as well as the placing of precast concrete boxes;
- 28b. Loading, unloading, and placing of barricades and barriers when work is performed under the jurisdiction of Local 731;
29. Laying of concrete, plastic, fiberglass and tile ducts;
30. All digging and concreting for guard rails and similar;
31. Signaling in connection with the handling of laborers' materials.
32. Coal passers;
33. Carrying coal to steam-operated construction machinery;
34. Pitmen on power shovels and cranes;
35. All hooking and unhooking of buckets, boxes, blasting mats, chaining stone and signaling in connection with hoisting of excavated material by cranes;
36. Tending, handling and cleaning of foot valves and sump pits;
37. All laborers' work in connection with the handling of all hoses, digging of holes, boring for pipe lines, sewer lines, ducts, utility lines and similar;
38. Setting up jacks;
39. Digging of pits for boring machines;
40. Tending of other trades;

41. Nipper carrying drills and hand tools to and from the blacksmiths;
42. Grading of crushed stone;
43. Servicing and placing of lanterns and light bombs;
44. Flagmen;
45. Fire watch;
46. Signalmen on all construction sites and work defined herein including, but not limited to, traffic control signalmen at construction sites;
47. Distribution of tools from toolhouse, warehouse, storeroom or shanty;
48. The use and operation of paving breakers used in chipping and breaking of masonry, concrete and pavement on foundations and below curb level, where reinforcing rod exists in concrete the use of a torch, as a tool of the trade, shall be utilized in demolition;
- 49a. The operating of mechanical concrete cutting saws, hand drills and mechanical drills;
- 49b. Oxy-gun cutting of reinforced concrete, steel, cast iron and granite as well as other related or incidental use of oxy-guns in connection with laborers' work;
50. Use of laser beams in connection with laborers' work;
51. The use of clay spades used in excavation of firm earth and hardpan;
52. In connection with the use of, and operation of, paving breakers used in chipping and breaking of masonry, concrete, rock and pavement, this can be done by laborers only when drillrunners are not working or available on the job, or where

there is less than a day's work to be done. In connection with the use of clay spades, used in the excavating of firm earth or hardpan, this can be done by the laborers where there is not continuous use of said tool;

When magazines of the 5th or 4th class are being used, a licensed laborer may be used, at the option of the Employer, as powder carriers on building operations only;

53. The use of pneumatic tampers, all manual tampers, power tampers, vibratory rollers controlled by hand;
54. The use of pickup trucks for moving men to and from various job sites, for moving out tools, for picking up water and other pickup uses;
55. The operation of power buggies in carrying out work customarily done by laborers represented by Local 731;
56. Laborers' work in yards in connection with the loading and hauling of laborers' tools and materials to and from jobs where laborers represented by Local 731 are engaged in foundation work for buildings as well as other laborers' work in yards;
57. Laborers' work in and on plants set up on job sites;
58. Removal of hazardous waste, hazardous soil, lead abatement, and/or asbestos removal in conjunction with the regular scope of work.
59. General cleanup at the jobsite on all work described in the above numbered items inclusive of, but not limited to, powerwashing, vacuuming, blowing, and sandblasting, whether manual, electric, or gas powered, exclusive of operator driven motor vehicles.

60. Performance of any maintenance work, pursuant to any contract with any government agency, quasi-governmental agency, or entity to replace or reconstruct any or all work described in the above numbered items.
61. All precast concrete work of any kind, excluding precast beams and H-piles. This includes but is not limited to precast boxes, barriers, railroad ties, parking lot bumpers, manholes, electric boxes, catch basins, duct banks/benches, sound walls, retaining walls, bollards, park benches, park tables, and flower pots;
62. All grading, digging, and excavation on all work described in this section A;
63. Manning of the shed and/or scale house;
64. Removal and treatment of mold;
65. When demolished or scrapped steel, exclusive of beams and girders, has been stockpiled for an intermediate period of time for later removal and disposal, the loading of the demolished or scrapped steel onto trucks or train cars shall be the work of Local 731;

B. LANDSCAPING IN CONNECTION WITH BUILDING PROJECTS inside and outside property lines, or first connection outside of the building penetration, and all work in conjunction with all jurisdiction within this category and all other categories of this agreement, including, but not limited to:

1. Excavating of and for pedestrian walks, curbs and tree pits;
2. Mixing, distributing and placing of topsoil, sod, manure, humus and fertilizer;

3. Grading, backfilling and raking of topsoil;
4. Planting of trees, shrubs, flowers and other decorative plants, as well as their cultivation and maintenance;
5. Seeding;
6. Tree topping, tree moving, tree removal, tree pruning, tree trimming and tree climbing;
7. Tending and operating aerial lift equipment, grinding machines, walk behind or stand-on lawnmowers, and stumping machines;
8. Cleaning and slashing of brush and trees by hand or with mechanical cutting methods around power lines or power facilities along the right-of-way on any construction site, along streets and highways;
9. Gardening;
- 10a. Loading and unloading of trees, shrubs and all other materials connected with the work of landscaping from the truck to the site of the job;
- 10b. In connection with watering of top soil, sod, manure, humus, fertilizer, shrubs, flowers, other decorative plants, trees, tree pits, brush, roads, walks, curbs, etc., the operation of hoses and other equipment connected with water tanks on trucks and similar;
11. Preparing subgrade for landscaping work;
12. Installing all pipes and tubing for drainage;
13. Ball and burlapping of trees;
14. Spreading of gravel and concreting wherever it may occur in connection with landscaping;
15. Digging tree wells, installing of trees;

16. Digging for benches on public highways and parks;
17. Rough grading around buildings;
18. Grading for pedestrian walks;
19. Excavating and grading for recreation areas;
20. Removal of hazardous waste, hazardous soil, lead abatement, and/or asbestos removal in conjunction with the regular scope of work.
21. General cleanup at the jobsite on all work described in the above numbered items, inclusive of, but not limited to power washing, vacuuming, blowing, and sandblasting, whether manual, electric or gas powered, exclusive of operator driven motor vehicles.
22. Performance of any maintenance work, pursuant to any contract with any government agency, quasi-governmental agency, or entity to replace or reconstruct any or all work described in the above numbered items.
23. All precast concrete work of any kind, excluding precast beams and H-piles. This includes but is not limited to precast boxes, barriers, railroad ties, parking lot bumpers, manholes, electric boxes, catch basins, duct banks/benches, sound walls, retaining walls, bollards, park benches, park tables, and flower pots;
24. All grading, digging, and excavation on all work described in this section B;
25. Manning of the shed and/or scale house;
26. Removal and treatment of mold;
27. All laborers work associated with irrigation systems, exclusive of valve manifolds;

28. When demolished or scrapped steel, exclusive of beams and girders, has been stockpiled for an intermediate period of time for later removal and disposal, the loading of the demolished or scrapped steel onto trucks or train cars shall be the work of Local 731;

C. HEAVY CONSTRUCTION AND ENGINEERING WORK inside and outside property lines, or first connection outside of the building penetration, and all work in conjunction with all jurisdiction within this category and all other categories of this agreement, including, but not limited to:

1. Track work;
2. Digging for the removal of all rails, tracks and ties, as well as removal of all rails, contact rails, third rails, tracks and ties and catwalks from any structure;
3. Loading, unloading, stockpiling, handling and distribution of all rails, contact rails, third rails, tracks, ties, tie-in pockets, and all other material in connection with track work;
4. Placing of or jacking track and ties at points of installation;
5. Placing, aligning, gauging, grading and fastening of all rails, contact rails and third rails;
6. Operation of power spike pullers, power spike drivers, power track jacks, tamping machines and similar rail and track laying equipment;
7. Spiking of all rails, contact rails, third rails, tracks and ties, including the welding, other fastening and other bonding of all running rails and tracks;

8. All grinding, burning or otherwise cutting of track;
9. Handling of tamping guns;
10. Cutting and drilling of all rail and track lining machinery;
11. Right-of-way clearance, excavation, grading, subgrading, ballasting and compacting of right-of-way;
- 12a. Setting of tie plates, bolting, leveling and gauging of all rails, contact rails and third rails, and spiking, whether by hand or mechanical means;
- 12b. The mixing, pouring and placing of grout, drypacking and concrete for all track related work, including but not limited to rails, ties, tracks, plates and columns;
13. Placing and tamping of ballast by hand or mechanical means;
14. Construction and/or relocation of mainlines; shoe flies, siding, grading, crossing, pipes, drainage and culverts connected with same as well as removal and replacing of all fences;
15. Placing of rip-rap on sea wall and placing of all wood, fiberglass, plastic, metal, pre-cast, retaining walls and concrete and other cribbing, whether in connection with track, highways or anywhere else it may occur;
16. The placing and fabricating of gabion and similar type cages and filling in conjunction with all heavy and industrial construction such as slopes, on highways and perimeters of tanks to be used as firewalls;
17. Laborers on open cut and free air tunnels;
18. Sewers;
- 18a. Sewer liners;

19. Sewage disposal plants, marine transfer stations, and all related cleanup tank work associated with same;
20. Sump pits;
21. Bridges;
22. Parks;
23. Elevated highways and ramps;
24. Pedestrian walks;
25. Subways;
- 25a. All subway work inclusive of stations, elevated or subgrade to egress to street level, walkways, pedestrian walks, mezzanines, passageways from one platform to another or from one station to another or from one track to another;
- 25b. Application of all materials used to protect rails, ties, etc., from rust, erosion, corrosion, mold, etc. for non-beautification purposes;
26. Highways;
27. Grade crossing eliminations;
28. Docks, decks, piers, runways over water, ramps and loading platforms;
29. Loading, unloading, piling, carrying and handling of materials, including lumber; cleaning lumber;
30. Loading, unloading, and placing of barricades and barriers when work is performed under the jurisdiction of Local 731;
31. Grading;
32. All laborers work associated with underpinning;
33. Cofferdams, shafts, the employment of top laborers on tunnels;

34. Distribution and handling of gasoline, propane gas and other fuel for heaters, etc., as well as handling and hooking up all equipment used in connection therewith;
35. Work not requiring skill and knowledge of a trade;
36. Carrying explosives;
37. Carrying reinforcing steel;
38. Tending, handling and cleaning of foot valves and sump pits;
39. All laborers' work in connection with the handling of all hoses;
40. Digging of holes;
41. Carrying fuel to machinery;
42. Mixing, placing, sandblasting, scarifying, bush hammering, dry packing, guniting and handling concrete, pumpcrete, prepack concrete, colcrete or other similar processes and cement including same for footings, piers, transformers and other holes, pits, trenches, piles, pile caps, retaining walls, underpinning, as well as all work in connection therewith when finishing tools are not required;
43. The application of materials, regardless of type of material and method of application, for protection from the elements for all precast and poured concrete;
44. Surface preparation of caissons and related structures;
45. All laborers' work in conjunction with vibroflotation;
46. The shoveling and packing of sand in sand piles;
47. The placing and pouring of concrete in all types of piles;
48. All concreting in sewers, sewage disposal plants, marine transfer stations, bridges, subways (inclusive of stations, elevated or subgrade to egress to street level, walkways,

pedestrian walks, mezzanines, passageways from one platform to another or from one station to another or from one track to another), grade crossing eliminations, cofferdams, shafts, catch basins and dry wells, substations, all utility encasements, ramps, elevated highways; retaining walls and slurry walls;

- 49a. All concrete work, (inclusive of concrete specialist work, if needed), as described above and in addition, the hooking on, signaling and dumping of concrete for tremie work over water on caissons, pilings, abutments, etc.;
- 49b. Setting up and removal of scaffolds in connection with laborers' work;
- 50. Removal of and handling, cleaning and fastening of all chutes, pipes, concrete buckets and elephant trunks used in placing of concrete as well as setting up and cleaning of conveyor belts used in the placing of concrete;
- 51a. Assisting in the removal of and removing of all wood, steel and other forms for concrete;
- 51b. Cleaning and oiling of all wood, steel and other forms for concrete;
- 51c. When demolished or scrapped steel, exclusive of beams and girders, has been stockpiled for an intermediate period of time for later removal and disposal, the loading of the demolished or scrapped steel onto trucks or train cars shall be the work of Local 731;
- 52. The pouring and guniting of concrete, pumpcrete, prepack concrete, colcrete, drypack or other similar processes, whether done by hand or any other process, including pouring

- and guniting of same for all precast and pre-stressed concrete such as piles, beams, boxes and columns;
53. All laborers' work in connection with chemical soil solidification, slurry walls, concrete cribbing, precast retaining walls, bentonite, mud mixing and all other methods of soil solidification;
 54. The handling and placing of grout for post tension cables on bridges, piers, runways and other engineering construction, including all types of grouting;
 55. Grouting of all equipment, including all types of grouting materials;
 56. The placing and spreading of gilsilate and other insulating materials;
 57. Carrying drills, hand tools and waterproofing materials;
 58. Installing, handling, loading, unloading, placing, hooking, unhooking, lowering into ditch, aligning, leveling and jointing of corrugated pipe, concrete pipe, plastic pipe, fiberglass pipe, other nonmetallic pipe, cast iron pipe, steel pipe, and ductile concrete lined pipe, and trenchless pipe;
 59. In connection with transportation lines, all laborers' work for the clearance of right-of-way preparatory to the installation of the pipe line, the demolition and removal of fences, the digging and trimming of trenches and ditches for pipe lines, work in connection with the bending of pipe except the mechanical work involved, laborers' work in connection with the distribution of pipe and skids and placing of said skids and pipe over the trench;
 60. The cleaning, scaling, etc., of the pipe;

61. All laborers' work in connection with the lineup crew, the cleaning, wrapping and doping of pipe before lowering after the welding of joints has been made, the cleaning, wrapping and doping of the pipe in all yards, the work in connection with the lowering of the pipe and the removal of the skids in connection with the backfilling of trenches after the pipe has been laid, all work in connection with cleanup after the pipe has been laid and trenches backfilled, demolition, take-up and reconditioning of old pipe, and pipelining of all kinds;
62. Laborers' work involved in refrigeration plants as well as in manufacturing and handling of ice to cool concrete;
63. Laborers' work on barges and floating equipment, and all other general and miscellaneous laborers' work in connection with the entire operation falling within the jurisdiction of Local 731;
- 64a. Wrapping, doping, coating, and treating of all pipe whether hot or cold, non-mechanical;
- 64b. The fusing and joining of all plastic pipes;
65. The handling of all steel plates;
66. Tending of other trades;
67. Placing of gravel or broken stone whenever or wherever necessary;
68. Grading of crushed stone for playground areas and walks;
69. All concrete work on playgrounds to include curbs, retaining walls, handball courts, swimming pools and wading pools, concrete cribbing and precast retaining walls;
70. All spading, chipping and breaking on foundations;

- 71a. In connection with the use of, and operation of, paving breakers used in chipping and breaking of masonry, concrete, rock and pavement, this can be done by laborers only when drillrunners are not working or available on the job, or where there is less than a day's work to be done. When magazines of the 5th or 4th class are being used, a licensed laborer may be used at the option of the Employers, as powder carriers;
- 71b. Oxy-gun cutting of reinforced concrete, steel, cast iron and granite as well as other related or incidental use of oxy-guns in connection with laborers' work;
- 71c. Use of laser beams in connection with laborers' work;
72. The use of clay spades used in the excavation of firm earth or hardpan and the use of pneumatic tampers;
73. All manual tampers;
74. Power tampers and vibratory rollers controlled by hand;
75. The use of pick-up trucks and/or vans for moving men to and from various job sites, for moving out tools, for picking up water and other pick-up uses;
76. Signaling in connection with the handling of laborers' materials;
77. All hooking and unhooking of buckets, boxes, blasting mats, chaining stone and signaling in connection with hoisting of excavated material by cranes;
78. All chaining of rock and other material handled by the laborers;
79. All digging, concreting, demolition (including the use of a torch for burning where reinforcing rod exists) and removal of existing and old concrete, old pipes not to be reused, removal

- of concrete slabs and other laborers' duties on and for elevated highways, pedestrian walks, docks, decks, bridges, ramps, runways over water, guard rails, barricades, pumping stations, pollution plants and other engineered structures;
80. Excavating, digging for sidewalks, including that for lighting posts, fence posts, duct lines, including placing of precast concrete boxes;
 81. Laying of concrete and tile ducts;
 82. Placing precast ducts and telephone or other ducts in subways, streets, shafts and highways;
 83. Shafts;
 84. Trimming, leveling, ditching by hand in connection with power shovels, cranes, etc.;
 85. Pitmen on power shovels;
 86. The operating of power buggies;
 87. The operating of mechanical concrete cutting saws, hand drills, core drilling and mechanical drills;
 88. Servicing and placing of lanterns and lightbombs;
 89. Flagmen, fire watchers, signalmen on all construction sites and work defined herein, including, but not limited to, traffic control signalmen at construction sites;
 90. Distribution of tools from warehouse, toolhouse, storeroom or shanty, as customarily done; and in connection with the loading and hauling of laborers' tools and materials to and from jobs where laborers represented by Local 731 are engaged in heavy construction or engineering work as was well as other laborers' work;
 91. Laborers' work in and on plants set up on job sites;

92. Laborers' work on all concrete on-site plants on job sites;
93. Removal of hazardous waste, hazardous soil, lead abatement, and/or asbestos removal in conjunction with the regular scope of work.
94. General cleanup at the jobsite on all work described in the above numbered items, inclusive of, but not limited to, power washing, vacuuming, blowing, and sandblasting, whether manual, electric or gas powered exclusive of operator driven motor vehicles.
95. Performance of any maintenance work, pursuant to any contract with any government agency, quasi-governmental agency, or entity to replace or reconstruct any or all work described in the above numbered items.
96. All precast concrete work of any kind, excluding precast beams and H-piles. This includes but is not limited to precast boxes, barriers, railroad ties, parking lot bumpers, manholes, electric boxes, catch basins, duct banks/benches, sound walls, retaining walls, bollards, park benches, park tables, and flower pots;
97. All grading, digging, and excavation on all work described in this section C;
98. Manning of the shed and/or scale house;
99. Removal and treatment of mold;

D. **LANDSCAPING IN CONNECTION WITH HEAVY CONSTRUCTION AND ENGINEERING WORK** inside and outside property lines, or first connection outside of the building penetration, and all work in conjunction with all jurisdiction within this category and all other categories of this agreement, including, but not limited to:

1. Excavating of and for pedestrian walks, curbs and tree pits;
2. Mixing, distributing and placing of topsoil, sod, manure, humus and fertilizer;
3. Grading, backfilling and raking of topsoil;
4. Planting of trees, shrubs, flowers and other decorative plants, as well as their cultivation and maintenance;
5. Seeding;
6. Treetopping;
7. Tree moving;
8. Tree removal;
9. Tree pruning;
10. Tree trimming and tree climbing;
11. Tending and operating aerial lift equipment, grinding machines, walk behind or stand-on lawn mowers, and stumping machines;
12. Cleaning and slashing of brush and trees by hand or with mechanical cutting methods around power lines or power facilities along the right-of-way on any construction site, along streets and highways;
13. Gardening;
- 14a. Loading and unloading of trees, shrubs and all other materials connected with the work of landscaping from the truck to the site of the job;

- 14b. In connection with watering of top soil, sod, manure, humus, fertilizer, shrubs, flowers, other decorative plants, trees, pits, brush, roads, walks, curbs, etc., the operation of hoses and other equipment connected with water tanks on trucks and similar;
15. Preparing subgrade for landscaping work;
16. Installing of all pipes and tubing for drainage;
17. Ball and burlapping of trees;
18. Spreading of gravel and concreting wherever it may occur in connection with landscaping;
19. Digging tree wells, installation of trees (planting, fertilizing, etc.);
20. Digging for benches on public highways and parks;
21. Rough grading around buildings;
22. Grading for pedestrian walks;
23. Excavating and grading for recreation areas;
24. Removal of hazardous waste, hazardous soil, lead abatement, and/or asbestos removal in conjunction with the regular scope of work.
25. General cleanup at the jobsite on all work described in the above numbered items, inclusive of, but not limited to, power washing, vacuuming, blowing and sandblasting, whether manual, electric or gas powered, exclusive of operator driven motor vehicles.
26. Performance of any maintenance work, pursuant to any contract with any government agency, quasi-governmental agency, or entity to replace or reconstruct any or all work described in the above numbered items.

27. All precast concrete work of any kind, excluding precast beams and H-piles. This includes but is not limited to precast boxes, barriers, railroad ties, parking lot bumpers, manholes, electric boxes, catch basins, duct banks/benches, sound walls, retaining walls, bollards, park benches, park tables, and flower pots;
28. All grading, digging, and excavation on all work described in this section D;
29. Manning of the shed and/or scale house;
30. Removal and treatment of mold;
31. All laborers work associated with irrigation systems, excluding valve manifolds;
32. When demolished or scrapped steel, exclusive of beams and girders, has been stockpiled for an intermediate period of time for later removal and disposal, the loading of the demolished or scrapped steel onto trucks or train cars shall be the work of Local 731;

ARTICLE VII

Wages and Conditions

Section 1 - Hours of Work

Eight (8) continuous hours shall constitute a day's work excluding lunch. Any failure to work these hours gives the Employer the right to pay only for hours actually worked. Where laborers are required to prepare for hazardous materials work prior to the start of their shift, and to remove such specialized clothing and/or equipment after their shift, the Employer shall pay the laborers overtime for such periods of preparation. The Employer may also direct that the

preparation be performed as part of their regular shift. The Employer will also provide such laborers with adequate wash up time prior to their lunch break and quitting time.

Section 2 - Shifts

(a) A single shift shall be the continuous eight and one-half (8 1/2) hours, including one-half (1/2) hour for mealtime. On unscheduled overtime work, any Laborer working over eleven (11) hours shall be entitled to an additional one half (1/2) hour meal period.

(b) When two (2) shifts are employed, the work period for each shift shall be a continuous eight and one-half (8 1/2) hours including one-half (1/2) hour for mealtime.

(c) When two (2) or more shifts are employed, single time shall be paid for each shift.

(d) When three (3) shifts are found necessary, each shift shall work seven and one-half (7 1/2) hours, but shall be paid for eight (8) hours of labor, and be permitted one-half (1/2) hour for mealtime.

(e) Varying Shift

On any Monday through Friday inclusive, the Employer can vary the shift commencement of any single, or two or three shifts by two (2) hours before or after normal shift commencement, in one-half (1/2) hour increments for any Employee and/or group of Employees on any shift day, and all work performed during said varied shift shall be paid for at the straight time rate, in conformity with the terms contained in the Agreement. When tide work is involved, the shift time commencement may vary in accordance with the shift times of other trades.

(f) Varying Lunch

The Employer can vary the commencement of the normal lunch period one (1) hour before or after same, for any Employee and/or group of

Employees on any day, and all work performed during said varied lunch period shall be paid for at the single time rate in conformity with the terms contained in this Agreement.

Section 3 - Overtime & Holidays

Overtime Defined

On scheduled overtime, including weekends, overtime shall first be offered to the crew who normally works at that job-site with the exception of specialty work. Upon refusal of said overtime, the contractor may bring in laborers from another job-site.

- (a) TIME AND ONE-HALF shall be paid for all work in excess of the regular eight (8) hour day single shift jobs, all work performed before or after the regular eight (8) hour day, starting at 8:00 A.M., except as to Subdivision (e) of Section 2 of this Article VII, shall be paid for at the time and one-half rate. The first eight (8) hours of any and all work performed Monday through Friday, inclusive on any off-shift shall be at the single time rate, in conformity with the terms contained in this Agreement (i.e. if the normal starting time is 7:00 A.M. through 3:30 P.M. each day and overtime is used continuously after the shift ended, or the labor returns within/prior to 6:59 A.M., all overtime hours shall be paid at time and one half. If the normal shift starts at 3:00 P.M. each day and if overtime is used after 11:00 P.M. and continues until 2:59 P.M. within 24 hours, all overtime hours shall be paid at time and one half).

- (b) TIME AND ONE-HALF will be paid for any work performed on Saturdays except that when Saturday is also a holiday to be observed as provided

for in Subprovision (e) of this Section 3, double time therefor shall be paid.

- (c) DOUBLE TIME shall be paid for any work performed on Sundays and the legal holidays to be observed as provided in Subprovision (e) of this Section 3 regardless of the day on which the holiday falls.
- (d) Except as provided in Subprovision (e) of Section 2, and Subprovisions (b) and (c) of this Section 3, the work period shall start at 8:00 A.M. Monday and end at 8:00 A.M. on Saturday, e.g.
 - (i) on three (3) shift jobs, the last shift shall work its final regular shift from midnight Friday to 8:00 A.M. Saturday for regular single time pay;
 - (ii) time and one-half pay shall be paid for each of the three(3) shifts between 8:00 A.M. Saturday and 8:00 A.M. Sunday and
 - (iii) double time shall be paid for each of the three (3) shifts between 8:00 A.M. of the holiday and 8:00 A.M. of the following morning and between 8:00 A.M. Sunday and 8:00 A.M. Monday.

(e) **Holidays**

Holidays to be observed as such are as follows:

New Year's Day	Columbus Day
Memorial Day	Thanksgiving Day*
Independence Day	Christmas Day
Labor Day*	

*Labor Day and Thanksgiving Day shall be paid holidays. All Employees covered by this Agreement shall receive eight (8) hours pay at the single time rate excluding Fringe Benefits even if such hours are not worked. If the Employee works on said Holidays, he shall receive an additional day's pay at the single time rate. Employees must work at least one (1) day in the calendar week in which the holiday occurs in order to be paid for said holiday.

All holidays which fall on Saturday, will not be observed on the preceding Friday. Holidays falling on Sunday shall be observed on the following Monday in accordance with State and Federal law.

- (f) **Martin Luther King's Birthday, Day after Thanksgiving, Presidents Day, Election Day in Presidential Years and Veteran's Day**

Single time if worked, but will not be paid if the Laborer does not work. Memorial Day shall be observed on the last Monday of May. Columbus Day shall be observed on the second Monday in October.

- (g) **Executive Board and Board of Auditors Meetings**

Members of the Executive Board and/or Board of Auditors of the Union shall be excused from work by the Employer and are to be paid only for hours worked in that day inclusive of foreman, when required for Union related meetings, not to exceed one (1) meeting per month. The Union shall provide notice to all members of these boards of such meetings far enough in advance to provide sufficient notice to the Employer.

(h) **Physical Examinations**

Due to new State and Federal Regulations related to specialized physical examinations now required as a result of work related to the removal and handling of toxic and hazardous materials both parties recognize the need for a Labor/Management Committee to address these concerns. Specifically, the parties have agreed that the Labor/Management Committee shall discuss the additional costs related to specialized examinations mandated by law. The parties are committed to amend this Agreement in accordance with these objectives, upon mutual agreement.

Section 4 - Wages

All wages payable under this Agreement shall become due and be paid on the job once each week. If for any reason the Employer terminates the services of an Employee working under this Agreement, then the accrued wages of the Employee shall be paid to him at the time of termination of employment; otherwise waiting time shall be charged for accrued wages.

If the Employee shall of his own volition leave the services of his Employer, then the Employer may retain his wages until the next regular payday. Employees shall be entitled to waiting time if not paid on regular paydays within working hours.

(a) The rate of wages to be paid per hour to Employees other than Foremen, shall be as follows:

***Effective Date:** 7/1/16 7/1/17 7/1/18 7/1/19 7/1/20 7/1/21

***Hourly Wage** \$41.00 TBD TBD TBD TBD TBD

* This Agreement between the Parties is a six year agreement from July 1, 2016 through April 30, 2022 with a 3 and one quarter percent (\$2.50) increase for each year during the term of this agreement. Allocation of each yearly increase will be determined by the Union prior to each collective bargaining year (July 1, of each year).

(b) No work shall be performed on any of the holidays referred to in Subprovision (e) of Section 3 of this Agreement unless paid for at the established double time rates for holidays.

Section 4.1 - Payment of Wages by Check

Notwithstanding anything herein to the contrary, Employers shall have the right to make weekly payments of wages by check provided:

- a. All legal requirements are complied with;
- b. Delivery of checks to Laborers shall be at least one day preceding a banking day; and
- c. A satisfactory Surety Bond or cash alternative in accordance with the provisions of Article VIII, Section 8 has been furnished to Laborers Local No. 731 by the Employer.
- d. Check stubs must bear the name of the employer and employers address, the name of the employee, the employee's identification number, the date of the check, the number of hours worked, the wage rate and the period for which the wages are being paid, year to date gross wages, weekly and year to date deductions, and withholdings, and net wages.

- e. At the Unions written request, social security numbers shall be provided by the employer to the Union.

In the event that a salary check is not honored by the bank on which drawn for any reason whatsoever, then the Laborers affected thereby shall be entitled to two (2) hour's pay plus the Employer shall pay all associated bank charges incurred because of inconvenience.

Section 5 - Conditions

(a) Shovels, tools, boots and other implements necessary to perform any kind of labor, including protective gear and equipment for handling hazardous materials, must be furnished by the Employer. A suitable exclusive place, with heat and electricity where feasible, wherein workmen may change their clothes shall be provided by the Employer, upon commencement of line item contract work, and will be of suitable size commensurate with the number of workers on the job site.

(b) In case personal belongings of any worker shall be lost through fire or theft, the Employer shall compensate each such worker for his loss, but such liability shall be limited to a sum not to exceed Two Hundred and Fifty Dollars (\$250.00) for each individual. Evidence of theft must be presented before this provision becomes effective.

(c) When a laborer (a) reports on a job after having been requested to do so by the Employer or (b) when a laborer already working on a job reports for work at his customary starting time, then, in either of such cases, if such laborer is not employed after so reporting on a particular day, the Employer shall pay such laborer two (2) hours wages for so reporting. However, the number of laborers to be paid two (2) hours wages for so reporting shall not exceed the number of laborers requested to report on the job by the Employer. However, when the

Employer's failure to provide work is due to bad weather or other conditions beyond the control of the Employer, then, such laborer shall not be entitled to such payment of wages for so reporting. Whenever a laborer is paid two (2) hours for so reporting, he must remain on the job for two (2) hours unless sooner released by the Employer.

(d) All wages payable under this Agreement shall become due and be paid on the job every week. At no time shall weekly wages be held back more than three (3) days after the last day of the work week. Said wages shall be paid, at the Employer's option, either (a) in cash, in envelopes, on the outside of which shall be plainly marked the Employer's name, the worker's name, his Social Security number, the hours worked and the amount of money enclosed, or (b) by check as per Section 4.1 of this Article.

Any deduction from wages now or hereafter required by law shall also be marked on the face of said pay envelopes. If workers are not paid as specified above, double time shall be paid for the two (2) hours of the regular weekly payday immediately succeeding the regular quitting time of said day and straight time for working time thereafter until paid, not exceeding fourteen (14) hours; provided, however, that the workers report to and remain on the job during the said fourteen (14) hours.

(e) The Contractor shall comply with all Federal, State and local government laws, and all regulations of public utilities concerning safety, health and fire protection.

Section 6 - Use of Intoxicant or Illegal Drug

The use of any intoxicant or illegal drug shall result in immediate dismissal of the Employee(s) involved.

Section 7 - Drug Testing Clause

The Employer and Union agree that, if required by either the Employer or by the Employer's contract with any City, State, Federal, and/or quasi-public agency, and/or alcohol abuse, and the Employees shall comply to the extent required. The Employer shall pay for the cost of the testing program.

The parties to this agreement have established a Department of Transportation ("DOT")-approved random drug testing program administered by a Certified Independent Service. The program is in full compliance with all Department of Transportation regulations, covering members of the union and their Employer's obligations under said regulations. The parties further agree that as a part of this program, a traveling collection facility will be available to be utilized by Employers whose employees are required to be tested.

If the Employer's contract with the Owner requires a more comprehensive drug testing program than provided for in the DOT regulations, the Owner's requirements shall apply.

Section 8 - Waiver of Paid Sick Leave

Local 731 waives any right or entitlement for paid sick leave that may be provided by any city, state, or federal law or regulation.

Section 9 - Paid Family Leave

Pursuant to New York State's Paid Family Leave Act, benefits provided under the act shall be paid for by deductions from the Employees' wages in an amount determined by the administrator of the benefit.

ARTICLE VIII

Section 1 - Welfare Fund

For the benefit of the Excavators Union Local 731 Welfare Fund (hereinafter called the "Welfare Fund"), the Employee beneficiaries thereof and the eligible dependents of said Employee beneficiaries, each of the Employers shall pay monthly to the Welfare Fund the sums equal to the aggregate of:

*Effective Date:	7/1/16	7/1/17	7/1/18	7/1/19	7/1/20	7/1/21
	\$17.33	TBD	TBD	TBD	TBD	TBD

***Allocation of each yearly increase will be determined by the Union prior to each new collective bargaining year (July 1 of each year), for each hour worked by all building, concrete, excavating and common laborers and by all Foremen of Laborers employed by each of the Employers in the territorial jurisdiction of Local 731. The foregoing payments shall be based upon hours worked, not on a premium portion of time and one-half or double time rate of pay. All such payments shall be made within thirty (30) days after the conclusion of the month in which such hours were worked.**

The Welfare Fund shall pay or provide for the payment of premiums on such policies of group life insurance, of group accidental death and dismemberment insurance, of group accident and health disability benefit insurance, of group medical, dental, drug, surgical, hospital and similar care expenses and/or benefits and also pay or provide for supplemental unemployment, disability, retirement, death and/or other supplemental benefits as well as such other welfare benefits as the Trustees of said Welfare Fund, in their discretion, may determine to provide (i) for such eligible laborers, their eligible spouses and/or other eligible

dependents as determined by said Trustees and (ii) for such eligible retired building concrete, excavating, and/or common laborers receiving benefits from the Excavators Union Local 731 Pension Fund, their eligible spouses and/or other eligible dependents as determined by said Trustees.

Such Welfare Fund shall provide the insurance necessary to qualify the Welfare Fund with an approved plan of insurance coverage to comply with the New York State Disability Insurance Law for all apprentices, laborers and foremen referred to in the first paragraph of this Article VIII. No payroll deductions permitted under the Disability Benefit Law are to be made by the Employers from the pay of any such laborers or foremen. The Welfare Fund shall pay all amounts required to be paid as and for the Employer and Employee contributions in compliance with the said Disability Benefit Law.

The Welfare Fund shall continue to be administered by Trustees, one-half (1/2) of whom shall be designated by Local 731 and the other one-half (1/2) of whom shall be designated by the G.C.A.

Each of the Employers shall comply with, and abide by, all rules, regulations, conditions, provisions and bylaws made, established and promulgated by said Trustees for the administration of said Welfare Fund.

Every present and future salaried regular Employee of Local 731, the Welfare Fund, the Excavators Union Local 731 Pension Fund, the Excavators Union Local 731 Annuity Fund and the LIUNA Local 731 Training Fund other than those of said Employees who are members of another union and participate in a welfare plan set up for the members of said other Union, may participate in the benefits provided herein for Employees of the Employers for whose benefit the aforementioned contributions are made to the Welfare Fund, provided that contributions at the rates hereinbefore stated are made to the Welfare Fund for or on behalf of said Employees

of Local 731, the Welfare Fund, the Excavators Union Local 731 Pension Fund, the Excavators Union Local 731 Annuity Fund, and the LIUNA Local 731 Training Fund by the respective Employers of said Employees on the same basis as outlined in the first paragraph of this Section 1 of Article VIII.

In order to provide for participation in the programs provided by the New York State Laborers and Employers Health and Safety Trust, an additional five cents (\$0.05) per hour for each hour worked shall be paid as part of the employer's contribution to the Excavators Union Local 731 Welfare Fund. This amount is included in the Welfare Fund Contribution listed in Section 1 of Article VIII.

Section 2 - Pension Fund

For the benefit of the Excavators Union Local 731 Pension Fund (hereinafter called the "Pension Fund"), the Employee beneficiaries thereof and the eligible dependents of said Employee beneficiaries, each of the Employers shall also pay monthly to the Pension Fund the sums equal to the aggregate of:

***Effective Date: 7/1/16 7/1/17 7/1/18 7/1/19 7/1/20 7/1/21**

\$14.20 TBD TBD TBD TBD TBD

***Allocation of each yearly increase will be determined by the Union prior to each new collective bargaining year (July 1 of each year), for each hour worked by all building, concrete, excavating and common laborers and by all Foremen of Laborers employed by each of the Employers in the territorial jurisdiction of Local 731. The foregoing payments shall be based upon hours worked, not on a premium portion of time and one-half or double time rate of pay. All such payments shall be made within thirty (30) days after the conclusion of the month in which such hours were worked.**

The Pension Fund shall continue to be administered by Trustees, one-half (1/2) of whom shall be designated by Local 731 and the other one-half (1/2) of whom shall be designated by the G.C.A.

Each of the Employers shall comply with, and abide by, all rules, regulations, conditions, provisions and bylaws made, established and promulgated by said Trustees for the administration of said Pension Fund.

Every present and future salaried regular employee of Local 731, the Welfare Fund, the Pension Fund, the Excavators Union Local 731 Annuity Fund, and the LIUNA Local 731 Training Fund other than those of said employees who are members of another union and participate in a pension plan set up for the members of said other union, may participate in the benefits provided herein for employees of each of the Employers for whose benefit the aforementioned contributions are made to the Pension Fund provided that contributions at the rates hereinbefore stated are made to the Pension Fund for or on behalf of said employees of Local 731, the Welfare Fund, the Pension Fund, the Excavators Union Local 731 Annuity Fund, and the LIUNA Local 731 Training Fund by the respective Employers of said employees on the same basis outlined in the first paragraph of this Section 2 of Article VIII.

Section 3 -- Annuity Fund

For the benefit of the Excavators Union Local 731 Annuity Fund (hereinafter called the "Annuity Fund"), the Employee beneficiaries thereof and the eligible dependents of said Employee beneficiaries, each of the Employers shall also pay monthly to the Annuity Fund the sums equal to the aggregate of:

***Effective Date: 7/1/16 7/1/17 7/1/18 7/1/19 7/1/20 7/1/21**

\$6.50 TBD TBD TBD TBD TBD

***Allocation of each yearly increase will be determined by the Union prior to each new collective bargaining year. (July 1 of each year),** for each hour worked by all building, concrete, excavating and common laborers and by all foremen of laborers employed by each of the Employers in the territorial jurisdiction of Local 731. The foregoing payments shall be based upon hours worked, not on the premium portion of time and one-half or double time rate of pay. All such payments shall be made within thirty (30) days after the conclusion of the month in which such hours were worked.

The Annuity Fund shall be administered by Trustees, one-half (1/2) of whom shall be designated by Local 731 and the other one-half (1/2) of whom shall be designated by the G.C.A.

Each of the Employers shall comply with, and abide by, all rules, regulations, conditions, provisions and bylaws made, established and promulgated by said Trustees for the administration of said Annuity Fund.

Every present and future salaried regular employee of Local 731, other than those of said employees who are members of another union and participate in an annuity plan set up for the members of said other union, may participate in the benefits provided herein for employees of the Employers for whose benefits the aforementioned contributions are made to the Annuity Fund, provided that contributions at the rates hereinbefore stated are made to the Annuity Fund for or on behalf of said employees of Local 731, by Local 731 on the same basis outlined in the first paragraph of this Section 3 of this Article VIII.

Section 4 - LIUNA Local 731 Training Fund

For the benefit of the LIUNA Local 731 Training Fund (hereinafter called the "Training Fund"), the Employee beneficiaries thereof and the eligible dependents of said Employee beneficiaries, each of the Employers

shall also pay monthly to the Training Fund the sums equal to the aggregate of:

***Effective Date: 7/1/16 7/1/17 7/1/18 7/1/19 7/1/20 7/1/21**

\$0.50 TBD TBD TBD TBD TBD

***Allocation of each yearly increase will be determined by the Union prior to each new collective bargaining year (July 1 of each year), for each hour worked by all building, concrete, excavating and common laborers and by all Foremen of Laborers employed by each of the Employers in the territorial jurisdiction of Local 731. The foregoing payments shall be based upon hours worked, not on premium portion of time and one-half or double time rate of pay.**

All such payments shall be made within thirty (30) days after the conclusion of the month in which such hours were worked.

The Training Fund shall be administered by four Trustees, two of whom shall be designated by Local 731 and the other two of whom shall be designated by the G.C.A.

Each of the Employers shall comply with, and abide by, all rules, regulations, conditions, provisions and bylaws made, established and promulgated by said Trustees for the administration of said Training Fund.

Every present and future salaried regular employee of Local 731, the Welfare Fund, the Pension Fund, the Annuity Fund and the Training Fund may participate in the benefits provided herein for employees of each of the Employers for whose benefit the aforementioned contributions are made to the Training Fund, provided that contributions at the rates hereinbefore stated are made to the Training Fund for or on behalf of said employees of Local 731, the Welfare Fund, the Pension Fund, the Annuity Fund and the Training Fund by the respective Employers of said

employees on the same basis outlined in the first paragraph of this Section 4 of Article VIII.

The Training Fund shall also train apprentices employed by contributing employers.

Any apprentice hired shall work as a productive member of the crew.

Section 5(a) - Union Membership Supplemental Dues

Each of the Employers shall also deduct weekly from the gross wages of each member of Local 731 employed by his Employer in the territorial jurisdiction of Local 731 the following sums:

***Effective Date: 7/1/16 7/1/17 7/1/18 7/1/19 7/1/20 7/1/21**

\$1.20 TBD TBD TBD TBD TBD

for each hour worked during said periods by each such member who has executed an authorization permitting, allowing or authorizing such deduction for or on account of supplemental membership dues due, or to become due, from such member to Local 731. The foregoing payments shall be based upon hours worked, not on premium portion of time and one-half or double time rate of pay. Within thirty (30) days after the conclusion of the month in which such hours are worked by each such Local 731 member, each of the Employers shall pay to Local 731 the aggregate of all such amounts deducted during such concluded month from the wages of each such member of Local 731. Each such monthly payment shall be made by each of the Employers to Local 731 at the same time that payment is made by each of the Employers to Excavators Union Local 731 Welfare Fund, Excavators Union Local 731 Pension Fund, Excavators Union Local 731 Annuity Fund and the LIUNA Local 731 Training Fund of the amounts required to be paid to each of said Funds pursuant to the provisions contained in the first paragraphs of Sections 1,2,3 and 4 of this Article VIII. No obligation or responsibility of any kind is assumed by the

Welfare Fund, the Pension Fund, the Annuity Fund or the Training Fund for the collection of said amounts. The only obligation of the Welfare Fund, Pension Fund, Annuity Fund and the Training Fund with respect to the remittances required to be sent or sent by each of the Employers to Local 731, by remittance(s) payable to Local 731, as aforementioned, is limited to the Fund(s) receiving same, sending or delivering to Local 731, not less frequently than quarter annually, all such remittances actually received by the Welfare Fund, Pension Fund, Annuity Fund and/or the Training Fund, less the costs to said Fund(s) of administration with respect to the collection of said amounts so deducted during such concluded month from the wages of each such member of Local 731, the bookkeeping, accounting, and forwarding or delivery of said remittances to Local 731, as well as the setting up of the machinery and procedures relating to such collection and remittance. Local 731 agrees to indemnify and to hold harmless the Employer from any and all claims, actions and/or proceedings arising out of said Dues Checkoff except those arising from the failure or refusal of the Employer to duly pay to Local 731, as hereinbefore provided, any and all amounts deducted from the wages of each of the Local 731 members referred to in the first sentence of this Section 5(a) as provided in the third and fourth sentences of this Section 5(a).

Section 5(b) - Political Action Committee

The Employer agrees to deduct and transmit to the New York Laborers' Political Action Committee the following sums:

*Effective Date:	7/1/16	7/1/17	7/1/18	7/1/19	7/1/20	7/1/21
	\$0.10	TBD	TBD	TBD	TBD	TBD

for each hour worked from the wages of those employees who have voluntarily authorized such contributions on the authorization forms provided for that purpose by the Union. These transmittals shall be made within thirty (30) days after the conclusion of the month in which said hours are worked. The Employer shall list the names of the Employees for whom such deductions have been made and the amount deducted for each such Employee in the Employer's monthly report showing Welfare Fund contributions, Pension Fund contributions, Annuity Fund contributions, Training Fund contributions, dues checkoff, etc. Local 731 agrees to indemnify and to hold harmless the Employer from any and all claims, actions and/or proceedings arising out of said deductions for contributions to the New York Laborers' Political Action Committee except those arising from the failure or refusal of the Employer to duly pay to the New York Laborers' Political Action Committee, as hereinbefore provided, any and all amounts deducted from the wages of each such authorizing Employee referred to in the first sentence of this Section 5b as provided in the second sentence of this Section 5b.

Section 5(c) - Duties of Employer To Funds With Respect To New Hires

The Employer will, as part of his monthly reporting procedures, add the name, social security number and address of new hirees working under the jurisdiction of Local 731, and the job location(s) of their current projects on forms provided by the Funds.

Section 6 - Heavy Construction Industry Fund

For the benefit of the Heavy Construction Industry Fund (hereinafter called "Heavy Construction Industry Fund"), each of the Employers shall also send monthly to the Welfare Fund its (the Employer's) remittance payable to the Heavy Construction Industry Fund for the aggregate of the sums of thirty cents (\$0.30) effective July 1, 2016, by all building,

concrete, excavating and common laborers and by all Foremen employed by each of the Employers in the territorial jurisdiction of Local 731, with the distinct understanding, however, that in connection therewith, except as hereinafter provided in the succeeding sentence hereof, the Welfare Fund neither assumes nor has any obligation or responsibility of any kind to anyone for the collection of said sums or otherwise. The foregoing payments shall be based upon hours worked, not on premium portion of time and one-half or double time rate of pay. The Welfare Fund's only obligation with respect to said remittances required to be sent by each of the Employers to the Welfare Fund by remittance payable to the Heavy Construction Industry Fund, as aforementioned, is limited to the Welfare Fund sending to the Heavy Construction Industry Fund not less frequently than monthly, all such remittances actually received by the Welfare Fund from Employers less than the Fund's cost of administration with respect to the collection of said contributions, the bookkeeping, accounting and forwarding of said remittances to the Heavy Construction Industry Fund as well as the setting up of machinery and procedures relating to such collection and remittance. All remittances of the sums referred to in the first sentence of this Section 6 shall be sent by each of the Employers to the Welfare Fund within thirty (30) days after the conclusion of the month in which the hours referred to in said first sentence were worked by the laborers and Foremen referred to in said first sentence.

Section 7(a)

Summary of Hourly Wages, Fringes, etc., for Laborers Other than Foremen:

Effective Date:	7/1/16	7/1/17	7/1/18	7/1/19	7/1/20	7/1/21
Hourly Wage	\$41.00	*TBD	*TBD	*TBD	*TBD	*TBD
Fringe Benefits	\$38.53					
Total Wage &						
Fringe Benefits	\$79.53					
H.C.I.F.	\$ 0.30					

Section 7(b)

Summary of Hourly Wages, Fringes, etc., for Foremen:

Effective Date:	7/1/16	7/1/17	7/1/18	7/1/19	7/1/20	7/1/21
Hourly Wage	\$43.50	*TBD	*TBD	*TBD	*TBD	*TBD
Fringe Benefits	\$38.53					
Total Wage &						
Fringe Benefits	\$82.03					
H.C.I.F.	\$ 0.30					

*Allocation of each yearly increase will be determined by the Union prior to each new collective bargaining year, (July 1 of each year).

Section 7(c) Checkoffs:

1. The employer shall deduct the following supplemental dues checkoff from the wages:

Effective Date:	7/1/16	7/1/17	7/1/18	7/1/19	7/1/20	7/1/21
	\$1.20	TBD	TBD	TBD	TBD	TBD

2. The Employer shall deduct the following sums for the Political Action Committee:

Effective Date: 7/1/16 7/1/17 7/1/18 7/1/19 7/1/20 7/1/21

\$0.10 TBD TBD TBD TBD TBD

Section 7(d)

New York State Laborers-Employers Cooperation and Education Trust

The Employers and Local 731 recognize that they must confront many issues of mutual concern which are more susceptible to resolution through labor-management cooperation than through collective bargaining. The Employers and Local 731 also recognize that workers as well as business benefit from labor-management cooperation. To seek resolution of these mutual concerns and to advance mutual interests through labor-management cooperative efforts, the Employers and Local 731 agree to participate in the New York State Laborers-Employers Cooperation and Education Trust ("LECET") which is established in accordance with Section 302(c)(9) of the Taft-Hartley Act [29 U.S. Code Section 186(c)(9)].

Each Employer shall pay to the New York State LECET ten cents (\$0.10) for each hour worked by all building, concrete, excavating and common laborers and by all foremen of laborers employed by each employer in the territorial jurisdiction of Local 731. All such payments shall be made within thirty (30) days after the conclusion of the month in which said hours were worked. The Employer shall list the names of the Employees for whom such contributions have been made and the amount contributed for each such Employee in the Employer's monthly report showing Excavators Local 731 Welfare, Pension, Annuity, and Training Funds (collectively "Benefits Funds") contributions, dues checkoff, etc. Such payments shall be sent, monthly, to the Benefits Funds with the understanding, however, that the Benefits Funds neither assume nor have

any obligation or responsibility of any kind to anyone for the collection of said sums or otherwise. The Benefits Funds' only obligation with respect to said remittance is limited to sending same to the New York State LECET, not less frequently than monthly.

Section 8(a) - Bonding

Each of the Employers shall provide a surety company bond to guarantee payment of wages as well as payment to the Welfare Fund, the Pension Fund, the Annuity Fund and the Training Fund of all contributions of fringe benefits required to be paid pursuant to the provisions of Sections 1,2, 3 and 4 of this Article VIII.

Such bonds shall be in the following amounts:

if the Employer employs 1 to 10 workers:	\$ 50,000.00
if the Employer employs 11 to 20 workers:	\$100,000.00
if the Employer employs 21 to 50 workers:	\$150,000.00
if the Employer employs over 50 workers:	\$150,000.00 plus
\$2,500.00 for each worker in excess of 50 workers	

Upon signing this agreement, an Employer shall, within six weeks, provide the requisite bond or submit a letter of rejection from a licensed surety bond company establishing to the satisfaction of Local 731 that the contractor is unable to obtain a bond. In the event the contractor is unable to obtain such bond, the contractor must deposit the cash alternative provided for in Section 8(b) of this Article VIII.

If neither the bond nor the cash alternative is received by Local 731 within six weeks after the signing of the agreement, Local 731 may remove such contractor's laborers without notice. During the six week grace period for obtaining the bond, the contractor must make weekly payments until the bond is provided or the requisite cash alternative is provided to the Union. If no weekly payment is received at the end of

three weeks, the contractor's laborers may be removed without notice. Upon the expiration of the term of the bond required by this section, or cancellation of same for any reason, the employer's laborers may be removed without notice.

Section 8(b) - Cash Alternative to Bond

In the event the Employer has established to the satisfaction of Local 731 that it is unable to obtain such surety company bond, it shall deliver to and deposit with Local 731 a cash alternative of \$5,000 per Employee. In the event monthly contributions exceed the bond amount or in the event the Employer has provided a cash deposit alternative to a bond and the monthly amount due for any month exceeds the sum on deposit, the Employer shall be required to increase the penal sum of the bond or said cash deposit alternative, as the case may be, upon ten (10) days written notice. In the event the Employer fails to provide such increased bond or increase said cash deposit, Local 731 may, upon fifteen (15) days further written notice, remove the workers under its jurisdiction. The cash alternative payment shall be made by certified check, bank cashiers check, or bank money order. Such payment shall be maintained in a regular or general bank account maintained by the Excavators Union Local 731 Benefits Funds in order to secure payment of any and all contributions due and to become due from the Employer to the Trustees of the Funds and said Trustees may deliver any part or all of said sum on deposit, to said Trustees in their exclusive discretion and whenever it is deemed advisable by said Trustees to do so, without further notice to the Employer, to use and apply part or all of said proceeds to the payment of any or all amounts due to the Funds pursuant to Article VIII hereof. No interest shall accrue for, be payable to or accountable to the Employer on said proceeds while same or any part

thereof remains on deposit and said proceeds may be commingled by the Trustees of the Funds with any other monies on deposit.

Such cash deposit alternative shall be applied against the last month's fringe benefits contributions due from the employer to the Funds at the termination of employer's performance of jurisdictional work, upon any other cessation of operations by the employer, or upon the filing, by the employer, for protection under the Bankruptcy Laws of the United States.

Section 9 - Method of Payment

The Union and Employer agree that the payment of all benefits shall be by one check made payable to the order of the Excavators Union Local 731 Benefits Funds. Said check shall be made out to a depository account and then shall be allotted in accordance with this collective bargaining agreement.

The Employer recognizes that when the payment of fringe benefit contributions to Excavators Union Local 731 Benefits Funds, or remittance of Union membership supplemental dues check-offs to the Union, pursuant to the Agreement is made by check or other negotiable instrument which is returned uncollected, Excavators Union Local 731 Benefits Funds and/or the Union incur additional cost and expense. The Employer hereby agrees that in the event any payment to the Excavators Union Local 731 Benefits Funds, or the Union, by check or other negotiable instrument, results in the check or negotiable instrument being returned without payment after being duly presented, the Employer shall be liable for additional damages in the amount of \$100.00 to cover such additional costs, charges and expenses. Nothing herein is intended, nor shall be interpreted, to mean that the Excavators Union Local 731 Benefits Funds, or Union, waive any other remedies including, but not limited to any liquidated damages

required to be paid pursuant to this Agreement, in the event Employer contributions are not paid in full and at the time required.

Section 10 - Records - Reports - Liability

The owner, proprietor, majority shareholder, member, president, vice president, secretary-treasurer, officer, board member or director of the corporation, company, limited liability company, joint venture or proprietorship acknowledges that he or she is vested with the authority and control over the submission of reports and/or payment of contributions to the Excavators Union Local 731 Benefit Funds and acknowledges that he or she shall be personally or individually obligated to submit the required reports and/or pay the required contributions to the Excavators Union Local 731 Benefit Funds for all work performed by Employees. Each of the Employers shall promptly furnish to the Trustees of said Welfare Fund, the Trustees of said Pension Fund, the Trustees of said Annuity Fund, the Trustees of said Training Fund and the Trustees of said Heavy Construction Industry Funds, on demand, any and all wage records relating to all building, concrete, excavating and common laborers and all Foremen of said laborers employed by each of the Employers in the territorial jurisdiction of Local 731. Besides such wage records, each of the Employers shall also provide to the Trustees, together with the payment of such contributions or, at such other intervals as the Trustees may request, written reports as to the wages paid to, and work records of, said laborers and Foremen, other payroll data, such as social security, unemployment insurance and compensation insurance records as well as any and all other data pertaining thereto and the contributions due or payable to the said Funds as the Trustees of said Funds may now or hereafter require.

The Employer is obligated to provide the aforesaid reports within 30 days after which the month in which the work was completed. If these reports are not submitted timely, a penalty of ten percent (10%) liquidated damages will be added to the amount then due for fringe benefit contributions, in addition to the interest due and payable outlined herein.

The books and records of the Employer shall be made available at all reasonable times for inspection and audit by, but not limited to, the accountants, independent auditors or other representatives of the Trustees of the Welfare, Pension, Annuity, Training and Heavy Construction Industry Funds. In addition, the books, records, information and documentation of any subsidiary, "alter ego" when performing work under the jurisdiction of Local 731 or joint venture of the Employer shall also be made available, at all reasonable times, for inspection and audit by, but not limited to, the accountants, independent auditors or other representatives of the Welfare, Pension, Annuity, Training and/or Heavy Construction Industry Funds.

The Employer shall retain, for a minimum period of six (6) years, all records necessary for the conduct of a proper audit in order that a designated representative of the Trustees may make periodic review to confirm that contributions owed pursuant to this Agreement are paid in full. If after the Trustees have made a reasonable request, the Employer fails to produce the documentation necessary for a proper audit, the Trustees, in their sole discretion, may determine that the Employer's monthly hours subject to contributions for each month of the requested audit period are the highest number of employee hours during the last twelve (12) months for which reports were filed. Such determination by

the Trustees shall constitute presumptive evidence of delinquency. Before making such determination, the Trustees shall give seven (7) days written notice to the Employer. Nothing herein shall mean that the Funds relinquish their right to commence legal proceedings to compel an examination of the Employer's books and records for audit.

When auditors are sent to audit the books and records of an Employer, and an appointment time is scheduled, and not canceled or rescheduled in a timely manner and the auditor cannot start at the appointed time and date and must return, through no fault of his own, the Employer shall be penalized and pay to the Benefits Fund the sum of two hundred fifty dollars (\$250.00) per auditor.

Any Employer whose account with the Welfare, Pension, Annuity, Heavy Construction Industry or Training Funds is found by the Trustees, upon regular or special audit, to be substantially delinquent (over \$1,000.00) is to be charged the full cost of this audit.

Where payment is made or an audit is conducted pursuant to a judgment or Court order, the Employer recognizes the right of the Trustees of Excavators Union Local 731 Benefits Fund to have the Court enter an order permanently enjoining the Employer and its agents, representatives, directors, officers, stockholders, successors and assigns, for the remaining term of this Agreement from failing, refusing or neglecting to submit the required contributions to Excavators Union Local 731 Benefits Funds and requiring the Employer to cooperate in an audit in accordance with the provisions of this Agreement. Once a

decision has been rendered by the Courts, it shall be considered final and binding.

Any Employer who is delinquent in paying its monthly contributions to the Excavators Union Local 731 Benefits Funds shall pay interest of ten percent (10%) per annum on all late payments or such amount of interest as the U.S. Department of Labor or the Internal Revenue Service may permit Trustees of employee benefit funds to collect for late payment of contributions, whichever amount is greater.

If any of the Employers does not fully and duly report or timely pay all amounts due as contributions to any or all of said funds in accordance with the above provisions, in any arbitration as provided herein, or in any action under the Multi-Employer Pension Plan Amendments Act of 1980 (hereinafter "Title") by a fiduciary for or on behalf of any or all of the Funds to enforce payment of contributions or to enforce Section 306 of the Title in which a judgment in favor of any or all of the Funds is awarded, the arbitrator or the Court shall award the Fund(s):

- A) the unpaid contributions;
- B) interest at the rate of ten percent (10%) on the unpaid contributions;
- C) an amount equal to the greater of -
 - i) interest on the unpaid contributions, or
 - ii) liquidated damages provided for under the plan in an amount not in excess of 20 percent;
- D) reasonable attorney's fees and costs of the action, to be paid by the respondent or defendant; and

- E) such other legal or equitable relief as the arbitrator or the court deems appropriate;
- F) if applicable, the penalty of ten percent (10%) on any remittance report that is filed late.

ARTICLE IX

Work Stoppage for Default in Payment of Wages and/or Welfare Pension and Annuity Payments

Section 1

Should any Employer default in making payment, when due, of any of the wages required to be paid pursuant to Article VII, Section 4 of this Agreement, the Union will remove labor without notice. Should any Employer be default in making payment, when due, of any of the benefits required and such default/default continues after three (3) working days written notice thereof is given to it (said defaulting Employer), pursuant to Article IV, Section 1, following which, or as a result of which, Local 731 removes or causes to be removed from any job any of the workers under its jurisdiction, then, and in either of such events, said Employer shall pay to each of such Employees, so removed, the amount of compensation lost by such Employees as a result of such removal, not exceeding, however, in any event, the equivalent of three (3) days pay at the straight time rate and Fringe Benefits. This clause notwithstanding, when an Employer declares itself or is declared under Chapter XI to be bankrupt and said Employer is then delinquent to the Funds, the Union in that instance may then remove its workers from the employ of said Employer. If Laborers are removed from a job for any reason under this Agreement upon which

wages, working dues, check-offs, PAC contributions or contributions to the Local 731 Trust Funds are unpaid, Laborers may refuse to return to work thereon until these wages, working dues check-offs, PAC contributions and/or contributions to the Laborers Local 731 Trust Funds are paid.

Section 2 - Removal of Workers upon Default

Should any Employer default in making payment, when due, of any of the amounts or contributions required to be paid to the Welfare Fund, the Pension Fund, the Annuity Fund and/or the Training Fund pursuant to Article VIII of this Agreement, and such default(s) continue(s) after three (3) working days written notice thereof is given to it (said defaulting Employer) in any manner provided in the Articles detailing "Notices" following which, or as a result of which, Local 731 removes or causes to be removed from any job any of the workers under its jurisdiction, then, and in either of such events, said Employer shall pay to each of such Employees, so removed, the amount of compensation lost by such Employee as a result of such removal, not exceeding, however, in any event, the equivalent of three (3) days pay at the straight time rate. This clause notwithstanding, when an Employer declares itself or is declared under Chapter XI to be bankrupt and said Employer is then delinquent to the Funds, the Union in that instance may then remove its workers from the employ of said Employer.

Section 3 - Arbitration

Should any controversy, dispute or disagreement arise between the parties hereto, the Union and any of the Employers or any of the

Employers and the Excavators Union Local 731 Welfare Fund (Welfare Fund), the Excavators Union Local 731 Pension Fund (Pension Fund), the Excavators Union Local 731 Annuity Fund (Annuity Fund), LIUNA Local 731 Training Fund (Training Fund) and/or the Heavy Construction Industry Fund, regarding or with respect to the payment or alleged nonpayment of any of the wages required to be paid to laborers and Foremen of laborers pursuant to Article VII hereof or contributions required to be paid to the Welfare Fund, the Pension Fund, the Annuity Fund and/or the Training Fund pursuant to Sections 1,2,3 and/or 4 of Article VIII hereof, interest on said contributions, liquidated damages, attorney's fees and/or costs as provided in Section 10 of Article VIII hereof, the union membership supplemental dues checkoff pursuant to Article VIII, Section 5(a) to the Union and any of the payments due to the Heavy Construction Industry Fund, pursuant to Section 6 of Article VIII hereof, then, and in any such event, any of the parties hereto, any of the Employers, the Union, the Welfare Fund, the Pension Fund, the Annuity Fund, the Training Fund, the Heavy Construction Industry Fund and/or the Trustees of one or more of said Funds or the attorney(s) for any one or more of them, may seek arbitration of said controversy, dispute or disagreement of any claim(s) arising therefrom. Any such controversy, dispute or disagreement shall be submitted to arbitration before a single arbitrator who is one of the impartial arbitrators designated below by serving upon the other party or parties to such controversy, dispute or disagreement, a demand for arbitration or a notice of intention to arbitrate, specifying the agreement pursuant to which arbitration is sought and the name and address of the party serving the notice, and the name and address of an officer or agent thereof if such person is an association or a corporation, and stating that unless the party served applies to stay the

arbitration within twenty (20) days after such service, he/she/they/it shall thereafter be precluded from objecting that a valid agreement was not made or has not been complied with and from asserting in court the bar of a limitation of time. Such notice or demand shall be served in the same manner as a summons or by registered or certified mail, return receipt requested. An application to stay arbitration must be made by the party served within twenty (20) days after service upon him/her/them/it of the notice or demand, or he/she/they/it shall be so precluded. Notice of such application shall be served in the same manner as a summons or by registered or certified mail, return receipt requested. Service of the notice of application may be made upon the adverse party, or upon his/her/their/its attorney if the attorney's name appears on the demand for arbitration or the notice of intention to arbitrate. Service of the notice of application by mail shall be timely if such notice of application is posted within the prescribed period. A hearing shall be held before such impartial arbitrator at a time, date and place designated by him within twenty (20) days after the expiration of the aforementioned twenty (20) day period and such impartial arbitrator shall make his award within twenty (20) days after the date of the closing of the hearing before him. The arbitrator shall have full and complete authority and power to decide any and all issues raised by the submission and to award appropriate damages, including, but not limited to the amount of wages found to be due, the amount of the unpaid contributions, interest thereon, liquidated damages, reasonable attorney's fees and the costs of the arbitration as prescribed in Section 10 of Article VIII of the within agreement plus the amount of the fees to be paid to the arbitrator, all of which shall be included in the award and be paid by the losing party. Such arbitrator, in his sole and

unreviewable discretion, may receive and consider the evidence of witnesses by affidavit but shall give such affidavit only such weight as the arbitrator deems it (said affidavit) to be entitled after giving consideration to any objections made to its admission. The award of such arbitrator shall be final, binding and conclusive upon the parties and judgment upon any award rendered by such arbitrator may be entered in any Court having jurisdiction thereof.

The arbitrator shall serve, in order, from a panel of two, as follows:

- 1) Stephen F. O'Beirne, Esq., 176 Washington Avenue Clifton, New Jersey 07011
- 2) Thomas J. Hanrahan, Esq., P.O. Box 140, Glen Rock, New Jersey 07452-0140.

If either arbitrator is not available or is unable or unwilling to serve for any reason, the other of them shall serve. If both are unwilling or unable to serve as such impartial arbitrator, then, and in that event, in their place and stead, the Chairman of the Employment Relations Board of the New York State Department of Labor shall designate and appoint an impartial arbitrator to serve.

The foregoing agreement of the parties to submit such controversy, dispute or disagreement or any claim arising therefrom, to an impartial arbitrator does not excuse any Employer or officer(s) of any Employer from any statutory, civil or criminal liability which may attach to or result from the failure of any such Employer to make payment of the aforementioned contributions, interest, liquidated damages, attorney's

fees and/or costs as provided in the last paragraph of Article VIII, Section 10 hereof. If the amount awarded by such impartial arbitrator is not paid within five (5) days after the making of such award, and Local 731 has not already removed or caused to be removed any of the Laborers and Foremen under its jurisdiction pursuant to Section 1 of Article IV hereinabove, Local 731 may remove or cause to be removed from any job of said Employer any of the laborers and Foremen of laborers under the jurisdiction of Local 731 employed thereon and, in such event, the Employer shall pay to each of those of such laborers and Foremen of laborers so removed, the amount of compensation lost by him as a result of such removal, not exceeding, however, in any event, the equivalent of three days' pay at straight time rates.

Section 4

The Employer hereby agrees to be bound by and to all terms and conditions of the Agreements and Declarations of Trust, as though it had actually signed the individual documents and further agrees to be bound by all actions taken by the Trustees of Excavators Local Union 731 Benefits Funds pursuant to said Agreements and Declarations of Trust, as amended, and their respective Plans, as amended, by all By-Laws, rules and resolutions adopted to regulate each of the Excavators Union Local 731 Benefits Funds.

ARTICLE X

Legality

Section 1

Any provisions of this Agreement which provide for union security or employment in a manner and to any extent prohibited by any law or the

determination of any governmental board or agency, shall be and hereby are of no force or effect during the term of any such prohibition. It is agreed that there shall be no discrimination against any Employee or prospective Employee in violation of the law. It is understood and agreed, however, that if any of the provisions which are hereby declared to be of no force or effect because of restrictions imposed by law are determined either by an Act of Congress or other legislative enactment or by a decision of the Court of highest recourse to be legal or permissible, then any such provisions shall immediately become and remain effective during the remainder of the term of this Agreement. Local 731 reserves the right to renegotiate any of the provisions which may be of no force or effect. In the event that there shall be a change in applicable laws as to union security, the parties shall renegotiate any provisions concerning union security.

Section 2

In the event that any provisions of this Agreement shall be declared to be in violation of the law, the remaining provisions of this Agreement shall remain in force and effect.

ARTICLE XI

Notices

All notices required to be given pursuant to this Agreement except for the Notice of and Demand for Arbitration provided in Section 2 of Article IV or Section 3 of Article IX of this Agreement shall be in writing and may be delivered in person, by facsimile transmission, by

ordinary first class mail, by certified mail, return receipt requested or by overnight guaranteed-next-day-delivery service to the Contractor.

ARTICLE XII

Execution of Agreement

If this Agreement is executed on behalf of any one of the Employers who is/are a male and/or a female person(s), or a combination of either of them, or a combination of either or any of them and a corporation, then, and in any such event(s) the relative words herein shall be read as if written in the masculine or feminine gender, or in the plural, as the case may be.

ARTICLE XIII

Term of Agreement

The term of this Agreement shall commence on and as of the 1st day of July 1, 2012 and shall terminate at midnight April 30th, 2022, and shall remain in full force and effect from year to year thereafter, unless written notice of termination of this agreement shall be given by either party, sixty (60) days prior to the date of termination of this agreement and each extension period. The provisions of this agreement, after the original term of six (6) years, will be those provisions negotiated and agreed to by Local 731 and The General Contractors Association of New York, Inc. or any successor or substitute.

ARTICLE XIV

Intent of Agreement

This Agreement supersedes and takes the place of all agreements heretofore made, as of July 1, 2016, by and between the parties hereto.

This Agreement and all of its terms and provisions are based on an effort and a spirit of bringing about more equitable conditions in the Construction Industry, and the language herein shall not be misconstrued to evade the principles or intent of this Agreement.

This Agreement may not be altered, modified or changed in any way unless any such proposed alteration, modification or change is in writing, is approved by the Union and is initialed or signed by an officer of the Union at the location in the Agreement of such proposed alteration, modification or change.

IN WITNESS WHEREOF, the parties have executed this Agreement as of the day and year stated in Article XIII hereof.

EMPLOYER:

BUILDING, CONCRETE, EXCAVATING
& COMMON LABORERS' UNION
LOCAL NO. 731 OF GREATER
NEW YORK, LONG ISLAND & VICINITY

BY: Domenick Cipollone
(Full and Exact Name of Employer)

BY: [Signature]
Frank Biancaniello
President

BY: Pres.
(Title of signing Representative)

BY: [Signature]
Joseph D'Amato
Business Manager

BY: [Signature]
(Title of Signing Representative)

BY: [Signature]
Dominic J. Valdner
Secretary-Treasurer

Dated: 9-29-16

APPENDIX A
UTILITY RATES

The Employees working under these rates receive full Pension, Welfare, Training and Annuity Contributions

LABORERS LOCAL 731
UTILITY RATES

Summary of Hourly Wages, Fringes, etc., for Utility Laborers:

Effective Date:	7/1/16	7/1/17	7/1/18	7/1/19	7/1/20	7/1/21
Hourly Wage	\$40.85	*TBD	*TBD	*TBD	*TBD	*TBD
Fringe Benefits	\$38.53					
Total Wage &						
Fringe Benefits	\$79.38					
H.C.I.F.	\$ 0.30					

Section 7(b)

Summary of Hourly Wages, Fringes, etc., for Utility Foremen:

Effective Date:	7/1/16	7/1/17	7/1/18	7/1/19	7/1/20	7/1/21
Hourly Wage	\$43.35	*TBD	*TBD	*TBD	*TBD	*TBD
Fringe Benefits	\$38.53					
Total Wage &						
Fringe Benefits	\$81.88					
H.C.I.F.	\$ 0.30					

*Allocation of each yearly increase will be determined by the Union prior to each new collective bargaining year, (July 1 of each year).

SPECIAL NOTE: DUES CHECKOFF

The Employer shall deduct the following supplemental dues checkoffs from the above wages:

Effective Date:	7/1/16	7/1/17	7/1/18	7/1/19	7/1/20	7/1/21
	\$1.20	TBD	TBD	TBD	TBD	TBD

**SPECIAL NOTE: DEFINITION OF FLAGMEN AND PEDESTRIAN TRAFFIC
MANAGER/CROSSING GUARD**

FLAGGERS

The duties of flaggers themselves have been determined to be manual and physical in nature, flaggers typically work on or around heavy or highway construction projects as part of the construction crew, and their work is integrally related and a necessary incident to the other construction activities at the site.

Activities shall include, but not be limited to, the movement of traffic cones or any other materials or equipment, the directing of trucks or equipment associated with the construction site, the opening or closing of construction gates, flagging or any other work normally performed by laborers who are members of Local 731.

PEDESTRIAN TRAFFIC MANAGER/CROSSING GUARD

The term "Pedestrian Crossing Guard" means a person employed to guide or temporarily control pedestrian, vehicular and bicycle traffic at streets adjacent to construction sites for safe, efficient traffic movement. The Pedestrian Crossing Guard will alleviate congestion by directing the flow of pedestrian and vehicular traffic away from the vicinity of the construction site.

The Pedestrian Crossing Guard will not direct the movement of construction equipment onto and off the site, direct or perform any other work associated with trucking associated with the construction site, be on the construction site or perform other duties commonly performed by flaggers or any other work normally performed by laborers who are members of Local 731.

PROJECT REFERENCE FORMS

A. PROJECT REFERENCES – CONTRACTS COMPLETED BY THE BIDDER

List all contracts substantially completed within the last four (4) years, up to a maximum of 10 Projects, in descending order of date of substantial completion.

Project & Location	Contract Type	Contract Amount (\$000)	Date Completed	Owner Reference & Tel. No.	Architect/Engineer Reference & Tel. No. (if different from owner)

A. PROJECT REFERENCES - SIMILAR CONTRACTS COMPLETED BY THE BIDDER

List all contracts substantially completed within the last 4 years similar to the contract being awarded, up to a maximum of 10, in descending order of date of substantial completion.

Project & Location	Contract Type	Contract Amount (\$000)	Date Completed	Owner Reference & Tel. No.	Architect/Engineer Reference & Tel. No. if different from owner
SEK201BN5 Collapsed Sewers Brooklyn	Sewer	\$5,385	31-Dec-16	NYC DEP Dan Lefkowitz, P.E. Deputy Chief Emergency Construction (718) 595-7657	Same
SEK002373 Catch Basins Various Locations Brooklyn	Sewer	\$849	07-Mar-16	NYC DDC Robert Yueh, P.E. Borough Director (718) 391-1937	Same
HWK-1129 Reconstruction of Nostrand Ave Brooklyn	Highway	\$23,509	30-Oct-15	NYC DDC Robert Yueh, P.E. Borough Director (718) 391-1937	Same
HWP2013KC Construction of Complex Pedestrian Ramps Brooklyn	Highway	\$3,158	30-Oct-15	NYC DDC Robert Yueh, P.E. Borough Director (718) 391-1937	Same
SEK201BN4 Collapsed Sewers Brooklyn	Sewer	\$5,313	29-Oct-15	NYC DEP Dan Lefkowitz, P.E. Deputy Chief Emergency Construction (718) 595-7657	Same
HWP2011KC Construction of Complex Pedestrian Ramps	Highway	3665	09-Apr-13	NYC DDC 2000	Same

A. PROJECT REFERENCES - SIMILAR CONTRACTS COMPLETED BY THE BIDDER

List all contracts substantially completed within the last 4 years similar to the contract being awarded, up to a maximum of 10, in descending order of date of substantial completion.

Project & Location	Contract Type	Contract Amount (\$000)	Date Completed	Owner Reference & Tel. No.	Architect/Engineer Reference & Tel. No. if different from owner
HWK100BUS Utica Ave SBS Brooklyn	Highway	\$14,856	02-Dec-19	NYC DDC Robert Yueh, P.E. Assistant Commissioner (718) 391-1937	Same
SEQ201BN9 Collapsed Sewers Queens	Sewer	\$7,827	30-Aug-19	NYC DEP Dan Lefkowitz, P.E. Deputy Chief Emergency Construction (718) 595-7657	Same
SEK201BN6 Collapsed Sewers Brooklyn	Sewer	\$5,313	31-May-18	NYC DEP Dan Lefkowitz, P.E. Deputy Chief Emergency Construction (718) 595-7657	Same
BEDA001 Accelerated Water Mains Brooklyn	Water	\$11,585	16-Oct-17	NYC DDC Robert Yueh, P.E. Borough Director (718) 391-1937	Same
HWCSCH3G2 School Traffic Safety Bronx, Manhattan & Brooklyn	Highway	\$3,958	29-Sep-17	NYC DDC Robert Yueh, P.E. Borough Director (718) 391-1937	Same

B. PROJECT REFERENCES – CONTRACTS CURRENTLY UNDER CONSTRUCTION BY THE BIDDER

List all contracts currently under construction similar to the contract being awarded.

Project & Location	Contract Type	Contract Amount (\$000)	Date Completed	Owner Reference & Tel. No.	Architect/Engineer Reference & Tel. No. (if different from owner)

C. PROJECT REFERENCES – PENDING CONTRACTS NOT YET STARTED BY THE BIDDER

List all contracts awarded to or won by the bidder but not yet started.

Project & Location	Contract Type	Contract Amount (\$000)	Date Completed	Owner Reference & Tel. No.	Architect/Engineer Reference & Tel. No. (if different from owner)

(NO TEXT ON THIS PAGE)

SAFETY QUESTIONNAIRE

The Bidder must include, with its bid, all information requested on this Safety Questionnaire. Failure to provide a completed and signed Safety Questionnaire at the time of bid opening may result in disqualification of the bid as non-responsive. This Safety Questionnaire will be reviewed as per Section V of the Safety Requirements for Construction Contracts, found in Volume 2 of the Contract.

1. Bidder Information:

Company Name: ADC CONSTRUCTION, LLC

DDC Project Number: SEQDN11

Company Size: Ten (10) employees or less
 Greater than ten (10) employees

Company has previously worked for DDC: YES NO

2. Type(s) of Construction Work:

Identify the types of work that the Bidder has performed in the last three years, and the types of work that are part of this Contract.

<u>TYPE OF WORK</u>	<u>LAST 3 YEARS</u>	<u>THIS PROJECT</u>
General Building Construction	<input type="checkbox"/>	<input type="checkbox"/>
Residential Building Construction	<input type="checkbox"/>	<input type="checkbox"/>
Nonresidential Building Construction	<input type="checkbox"/>	<input type="checkbox"/>
Heavy Construction, except building	<input type="checkbox"/>	<input type="checkbox"/>
Highway and Street Construction	<input checked="" type="checkbox"/>	<input checked="" type="checkbox"/>
Heavy Construction, except highways	<input type="checkbox"/>	<input type="checkbox"/>
Plumbing, Heating, HVAC	<input type="checkbox"/>	<input type="checkbox"/>
Painting and Paper Hanging	<input type="checkbox"/>	<input type="checkbox"/>
Electrical Work	<input type="checkbox"/>	<input type="checkbox"/>
Masonry, Stonework and Plastering	<input type="checkbox"/>	<input type="checkbox"/>
Carpentry and Floor Work	<input type="checkbox"/>	<input type="checkbox"/>
Roofing, Siding, and Sheet Metal	<input type="checkbox"/>	<input type="checkbox"/>
Concrete Work	<input type="checkbox"/>	<input type="checkbox"/>
Specialty Trade Contracting	<input type="checkbox"/>	<input type="checkbox"/>
Asbestos Abatement	<input type="checkbox"/>	<input type="checkbox"/>
Other (specify) _____	<input type="checkbox"/>	<input type="checkbox"/>

3. Experience Modification Rate:

The Experience Modification Rate (EMR) is a rating generated by the National Council of Compensation Insurance (NCCI). This rating is used to determine the contractor's premium for worker's compensation insurance. The Bidder / Contractor may obtain its EMR by contacting its insurance broker or the NCCI. If the Bidder cannot obtain its EMR, it must submit a written explanation as to why.

The Bidder must indicate its Intrastate and Interstate EMR for the past three years. [Note: For contractors with less than three years of experience, the EMR will be considered to be 1.00].

YEAR	INTRASTATE RATE	INTERSTATE RATE
16	0.33	
17	0.80	
18	0.88	

If the Intrastate and/or Interstate EMR for any of the past three years is greater than 1.00, the Bidder / Contractor must attach, to this questionnaire, a written explanation for the rating and identify what corrective action was taken to correct the situation resulting in that rating.

4. OSHA Information:

YES NO Contractor has received a willful violation issued by OSHA or a New York City Department of Buildings (NYCDOB) construction-related violation within the last three years.

YES NO Contractor has had an incident requiring OSHA notification within 8 hours (all work-related fatalities) or an incident requiring OSHA notification within 24 hours (work-related in-patient hospitalization, amputation and all loss of an eye).

The OSHA Form 300 "Log of Work-Related Injuries and Illnesses" and OSHA Form 300A "Summary of Work-Related Injuries and Illnesses" must be submitted for the last three years for Contractors with more than ten employees.

The Bidder / Contractor must indicate the total number of hours worked by its employees, as reflected in payroll records for the past three (3) years.

The Bidder / Contractor must submit the Incident Rate for Lost Time Injuries (the Incident Rate) for the past three (3) years. The Incident Rate is calculated in accordance with the formula set forth below. For each given year, the total number of incidents is the total number of non-fatal injuries and illnesses reported on the OSHA Form 300 and OSHA Form 300A. The 200,000 hours represents the equivalent of 100 employees working forty hours a week, fifty (50) weeks per year.

$$\text{Incident Rate} = \frac{\text{Total Number of Incidents} \times 200,000}{\text{Total Number of Hours Worked by Employees}}$$

YEAR	TOTAL NUMBERS OF HOURS WORKED BY EMPLOYEES	INCIDENT RATE
16	123,433	6.48
17	128,844	6.20
18	128,991	4.65

If the Bidder's / Contractor's Incident Rate for any of the past three years is one point higher than the Incident Rate for the type of construction it performs (listed below), the Bidder / Contractor must attach, to this questionnaire, a written explanation for the relatively high rate.

General Building Construction	8.5
Residential Building Construction.....	7.0
Nonresidential Building Construction	10.2
Heavy Construction, except building	8.7
Highway and Street Construction.....	9.7
Heavy Construction, except highways	8.3
Plumbing, Heating, HVAC.....	11.3
Painting and Paper Hanging	6.9
Electrical Work.....	9.5
Masonry, Stonework and Plastering.....	10.5
Carpentry and Floor Work.....	12.2
Roofing, Siding, and Sheet Metal.....	10.3
Concrete Work.....	8.6
Specialty Trade Contracting.....	8.6

5. Safety Performance on Previous DDC Project(s)

YES NO Fatality or an incident requiring OSHA notification within 24 hours (work-related in-patient hospitalization, amputation and all loss of an eye) on DDC Project(s) within the last three (3) years.

DDC Project Number(s): _____, _____, _____

The Bidder hereby affirms that all the information provided in this Safety Questionnaire and all additional pages and/or attachments, if applicable, consist of accurate representations.

Date: 12/5/19

By: *Donald G. [Signature]*
(Signature of Bidder: Owner, Partner, Corporate Officer)

Title: PRESIDENT

(NO TEXT ON THIS PAGE)

Log of Work-Related Injuries and Illnesses

You must record information about every work-related death and about every work-related injury or illness that involves loss of consciousness, restricted work activity or job transfer, days away from work, or medical treatment beyond first aid. You must also record significant work-related injuries and illnesses that are diagnosed by a physician or licensed health care professional. You must also record work-related injuries and illnesses that meet any of the specific recording criteria listed in 29 CFR Part 1904.8 through 1904.12. Feel free to use two lines for a single case if you need to. You must complete an Injury and Illness Incident Report (OSHA Form 301) or equivalent form for each injury or illness recorded on this form. If you're not sure whether a case is recordable, call your local OSHA office for help.

Attention: This form contains information relating to employee health and must be used in a manner that protects the confidentiality of employees to the extent possible while the information is being used for occupational safety and health purposes.

Year 2016

U.S. Department of Labor
Occupational Safety and Health Administration

Form approved OMB no. 1218-0175

Establishment name: AOC CONSTRUCTION LLC
City: MASPETH State: NY

(A) Case no. (B) Employee's name (C) Job title (e.g., Welder) (D) Date of injury or onset of illness (E) Where the event occurred (e.g., Loading dock north end)

(F) Describe injury or illness, parts of body affected, and object/substance that directly injured or made person ill (e.g., Second degree burns on right forearm from oxy/acetylene torch)

CHECK ONLY ONE box for each case based on the most serious condition for that case:

Death (G)

Days away from work (H)

Restricted work activity or job transfer (I)

Other recordable condition (J)

Any loss of consciousness (K)

On job transfer or restriction (L)

(M) Check the "light" column or choose one type of illness:

Injury (1) Skin disorder (2) Respiratory condition (3) Poisoning (4) Hearing loss (5) All other illnesses (6)

2016-4 FRANCISCO DOMINGUEZ 1/2/1 monthly JOBSITE

BLEED ON CONCRETE DISLOADED FALLING AND STRIKING EMPLOYEE ON RIGHT PINKY FINGER

2016-3 JOSE ENRIQUEDO 11/14 monthly JOBSITE

WHILE LOADING AND SECURING ROLLER AND SWEEPER ONTO FLATBED OF TRUCK SWEEPER FELL WITH THE RIGHT SIDE OF HIS HEAD HITTING HANDLE OF SWEEPER

2016-2 ERIK PALMERI 6/17 monthly E 129ND STREET AND AVE M, BROOKLYN

WHILE WALKING PAST TRUCK TO LOOK AT DAMAGED AIR TANK VALVE, SLIPPED AND HIT HEAD ONTO 40 F EXCAVATOR

2016-1 JOSE MONTERO 6/9 monthly INFO 1255 E 103RD STREET, BROOKLYN

INSTALLING NEW WATER MAIN, TRENCH 4 FT DEEP. SIDE CAVED IN LEGS WERE BURIED UP TO KNEE. CLAIMED HE HAD CHEST PRESSURE

monthly

monthly

monthly

monthly

monthly

monthly

Be sure to transfer these totals to the Summary page (Form 300A) before you post it.

13 days 0 days

3 0 0 0 0 1

(1) Injury (2) Skin disorder (3) Respiratory condition (4) Poisoning (5) Hearing loss (6) All other illnesses

Public reporting burden for this collection of information is estimated to average 14 minutes per response, including time to review the instructions, search existing data sources, gather the data needed, and complete and review the collection of information. Persons are not required to respond to the collection of information unless it displays a currently valid OMB control number. If you have any comments about these estimates or any other aspect of this data collection, contact: US Department of Labor, OSHA Office of Statistical Analysis, Room N-3604, 200 Constitution Avenue, NW, Washington, DC 20210. Do not send the completed forms to this office.

Summary of Work-Related Injuries and Illnesses

Year 2016

U.S. Department of Labor
Occupational Safety and Health Administration
Form 300A (Rev. 01/2004)

All establishments covered by Part 1904 must complete this Summary page, even if no work-related injuries or illnesses occurred during the year. Remember to review the Log to verify that the entries are complete and accurate before completing this summary.

Using the Log, count the individual entries you made for each category. Then write the totals below, making sure you've added the entries from every page of the Log. If you had no cases, write "0."

Employees, former employees, and their representatives have the right to review the OSHA Form 300 in its entirety. They also have limited access to the OSHA Form 301 or its equivalent. See 29 CFR Part 1904.35, in OSHA's recordkeeping rule, for further details on the access provisions for these forms.

Number of Cases

Total number of deaths	Total number of cases with days away from work	Total number of cases with job transfer or restriction	Total number of other recordable cases
0	4	0	0
(g)	(h)	(i)	(j)

Number of Days

Total number of days away from work	Total number of days of job transfer or restriction
13	0
(k)	(l)

Injury and Illness Types

Total number of ...

(1) Injuries (M)	3	(4) Poisonings	0
(2) Skin disorders	0	(5) Hearing loss	0
(3) Respiratory conditions	0	(6) All other illnesses	1

Post this Summary page from February 1 to April 30 of the year following the year covered by the form.

Public reporting burden for this collection of information is estimated to average 50 minutes per response, including time to review the instructions, search and gather the data needed, and complete and review the collection of information. Persons are not required to respond to the collection of information unless it displays a currently valid OMB control number. If you have any comments about these estimates or any other aspect of this data collection, contact: US Department of Labor, OSHA, Office of Statistical Analysis, Room N-3604, 300 Constitution Avenue, NW, Washington, DC 20210. Do not send the completed form to this office.

Establishment Information

Your establishment name **ADC CONSTRUCTION LLC**

Street **58-08 48TH STREET**

City **MASPETH** State **NY** ZIP **11378**

Industry description (e.g., *Manufacture of motor truck trailers*)

Standard Industrial Classification (SIC), if known (e.g., 3715)

OR

North American Industrial Classification (NAICS), if known (e.g., 336212)

Employment Information (If you don't have these figures, see the Worksheet on the back of this page to estimate.)

Annual average number of employees **58**

Total hours worked by all employees last year **123433**

Sign here

Knowingly falsifying this document may result in a fine.

I certify that I have examined this document and that to the best of my knowledge the statistics are true, accurate, and complete.

Michael Shmalko
 Title **Proj Mgr.**
 Date **3 25 2016**
 Phone **718 628 5855**

Log of Work-Related Injuries and Illnesses

Attention: This form contains information relating to employee health and must be used in a manner that protects the confidentiality of employees to the extent possible while the information is being used for occupational safety and health purposes.

Year 2017

U.S. Department of Labor

Occupational Safety and Health Administration

Form approved OMB no. 1218-0176

You must record information about every work-related death and about every work-related injury or illness that involves loss of consciousness, restricted work activity or job transfer, days away from work, or medical treatment beyond first aid. You must also record significant work-related injuries and illnesses that are diagnosed by a physician or licensed health care professional. You must also record work-related injuries and illnesses that meet any of the specific recording criteria listed in 29 CFR Part 1904.8 through 1904.12. Feel free to use two lines for a single case if you need to. You must complete an injury and illness incident report (OSHA Form 301) or equivalent form for each injury or illness recorded on this form. If you're not sure whether a case is recordable, call your local OSHA office for help.

Establishment name: ADC CONSTRUCTION LLC
 City: MASSETH State: NY

CHECK ONLY ONE box for each injury or illness case.

Enter the number of days the injured or ill worker was:

Check the "major" columns or check one type of illness:

(A) Case no. (B) Employee's name (C) Job title (e.g., Welder) (D) Date of injury or onset of illness (E) Where the event occurred (e.g., Loading dock north end) (F) Describe injury or illness, parts of body affected, and object/instrument that directly injured or made person ill (e.g., Second degree burns on right forearm from oxyacetylene torch)

Health (G) (H) Days away from work (I) Restricted work activity or job transfer (J) Other recordable illness (K) Awaiting further work (L) On job transfer or restriction (M) Injury (1) (2) (3) (4) (5) (6)

(N) 0 days 35 days

(1) (2) (3) (4) (5) (6)

2017-3 MANUEL FORMOSO CARPENTER 9/14 monthly JOBSITE while picking up a sawing, felt pain in left biceps muscle 4th at and 5th eye brooklyn 0 days 35 days

2017-4 MANUEL FORMOSO CARPENTER 9/14 monthly JOBSITE employee states that while he was picking up a sand bag he felt pain in his biceps muscle 1 days 0 days

2017-2 VALDEMAR PIMENTEL LABORER 5/11 monthly CONSTRUCTION SITE ANOTHER LABORER ACCIDENTLY BUMPED INTO HIM ON HIS LEFT NECK/FOURTH AND SEVENTH NECK BONE 7 days 21 days

2017-1 MANUEL FORMOSO CARPENTER 5/2 monthly JOBSITE left index finger, wood limbs and sheaving 28 days 15 days

_____ monthly _____ _____ days _____ days

_____ monthly _____ _____ days _____ days

_____ monthly _____ _____ days _____ days

_____ monthly _____ _____ days _____ days

_____ monthly _____ _____ days _____ days

_____ monthly _____ _____ days _____ days

_____ monthly _____ _____ days _____ days

_____ monthly _____ _____ days _____ days

_____ monthly _____ _____ days _____ days

_____ monthly _____ _____ days _____ days

_____ monthly _____ _____ days _____ days

_____ monthly _____ _____ days _____ days

_____ monthly _____ _____ days _____ days

Public reporting burden for this collection of information is estimated to average 14 minutes per response, including time to review the instructions, search and gather the data needed, and complete and review the collection of data. Persons are not required to respond to the collection of information unless it displays a currently valid OMB control number. If you have any comments about this collection of information, please write to Washington, DC 20503. Send comments to the Office of Management and Budget, Paperwork Project Director, Paperwork Project, Washington, DC 20503. Do not send the completed forms to this office.

Be sure to transfer these totals to the Summary page (Form 300A) before you post it.

Page 1 of 1

(1) Injury (2) Skin disorder (3) Respiratory condition (4) Poisoning (5) Hearing loss (6) All other illnesses

Summary of Work-Related Injuries and Illnesses

Year 2017

U.S. Department of Labor
Occupational Safety and Health Administration
Form approved OMB no. 1218-0176

All establishments covered by Part 1904 must complete this Summary page, even if no work-related injuries or illnesses occurred during the year. Remember to review the Log to verify that the entries are complete and accurate before completing this summary.

Using the Log, count the individual entries you made for each category. Then write the totals below, making sure you've added the entries from every page of the Log. If you had no cases, write "0."

Employees, former employees, and their representatives have the right to review the OSHA Form 300 in its entirety. They also have limited access to the OSHA Form 301 or its equivalent. See 29 CFR Part 1904.35. In OSHA's recordkeeping rule, for further details on the access provisions for these forms.

Number of Cases

Total number of deaths	Total number of cases with days away from work	Total number of cases with job transfer or restriction	Total number of other recordable cases
0	3	1	0
(g)	(h)	(i)	(j)

Number of Days

Total number of days away from work	Total number of days of job transfer or restriction
36	71
(k)	(l)

Injury and Illness Types

Total number of ...	(M)	(4) Poisonings	(5) Hearing loss	(9) All other illnesses
(1) Injuries	4		0	0
(2) Skin disorders	0		0	0
(3) Respiratory conditions	0		0	0

Post this Summary page from February 1 to April 30 of the year following the year covered by the form.

Public reporting burden for this collection of information is estimated to average 50 minutes per response, including time to review the instructions, search and gather the data needed, and complete and review the collection of information. Persons are not required to respond to the collection of information unless it displays a currently valid OMB control number. If you have any comments about these estimates or any other aspect of this data collection, contact: US Dept. of Labor, OSHA, Office of Statistical Analysis, Room N-3604, 200 Constitution Avenue, NW, Washington, DC 20210. Do not send the completed form to this office.

Establishment Information

Your establishment name: **ADC CONSTRUCTION LLC**
 Street: **58-08 48TH STREET**
 City: **MASPETH** State: **NY** ZIP: **11378**

Industry description (e.g., Manufacturer of motor truck trailers)

Standard Industrial Classification (SIC), if known (e.g., 3715)

OR

North American Industrial Classification (NAICS), if known (e.g., 336212)

Employment Information (If you don't have these figures, see the Worksheet on the back of this page to estimate.)

Annual average number of employees: **54**

Total hours worked by all employees last year: **128844**

Sign here

Knowingly falsifying this document may result in a fine.

I certify that I have examined this document and that to the best of my knowledge, the entries are true, accurate, and complete.

Melinda Blumstein
 Title: **Project Manager**
 Phone: **718.628.5555**

Log of Work-Related Injuries and Illnesses

You must record information about every work-related death and about every work-related injury or illness that involves loss of consciousness, restricted work activity or job transfer, days away from work, or medical treatment beyond first aid. You must also record significant work-related injuries and illnesses that are diagnosed by a physician or licensed health care professional. You must also record work-related injuries and illnesses that meet any of the specific recording criteria listed in 29 CFR Part 1904.8 through 1904.12. Feel free to use two lines for a single case if you need to. You must complete an Injury and Illness Incident Report (OSHA Form 301) or equivalent form for each injury or illness recorded on this form, if you're not sure whether a case is recordable, call your local OSHA office for help.

Attention: This form contains information relating to employee health and must be used in a manner that protects the confidentiality of employees to the extent possible while the information is being used for occupational safety and health purposes.

Year 2018

U.S. Department of Labor

Occupational Safety and Health Administration
Form approved OMB no. 1218-0175

Establishment name: ADC CONSTRUCTION, LLC
City: MASSETH State: NY

2018-1 JAMES BELLO TEAMSTER TRUCK DRIVER 2/12 JOBSITE location of 3rd street between smith st and hoxl st picking up tractor on back side of boom truck, tractor dislodged, came down and hit employee on back portion of leg

2018-2 ERIK PALMERI TEAMSTER TRUCK DRIVER 6/25 JOBSITE getting out of truck, step on piece of timber curb on the edge and rolled right ankle

2018-3 CASIMIRO QUINTERO CARPENTER 3/28 JOBSITE step and fell into opening of sewer manhole, right arm and shoulder injured

2018-4 JAMES BELLO TEAMSTER TRUCK DRIVER 2/12 JOBSITE location of 3rd street between smith st and hoxl st picking up tractor on back side of boom truck, tractor dislodged, came down and hit employee on back portion of leg

2018-5 ERIK PALMERI TEAMSTER TRUCK DRIVER 6/25 JOBSITE getting out of truck, step on piece of timber curb on the edge and rolled right ankle

2018-6 CASIMIRO QUINTERO CARPENTER 3/28 JOBSITE step and fell into opening of sewer manhole, right arm and shoulder injured

2018-7 JAMES BELLO TEAMSTER TRUCK DRIVER 2/12 JOBSITE location of 3rd street between smith st and hoxl st picking up tractor on back side of boom truck, tractor dislodged, came down and hit employee on back portion of leg

2018-8 ERIK PALMERI TEAMSTER TRUCK DRIVER 6/25 JOBSITE getting out of truck, step on piece of timber curb on the edge and rolled right ankle

2018-9 CASIMIRO QUINTERO CARPENTER 3/28 JOBSITE step and fell into opening of sewer manhole, right arm and shoulder injured

2018-10 JAMES BELLO TEAMSTER TRUCK DRIVER 2/12 JOBSITE location of 3rd street between smith st and hoxl st picking up tractor on back side of boom truck, tractor dislodged, came down and hit employee on back portion of leg

2018-11 ERIK PALMERI TEAMSTER TRUCK DRIVER 6/25 JOBSITE getting out of truck, step on piece of timber curb on the edge and rolled right ankle

2018-12 CASIMIRO QUINTERO CARPENTER 3/28 JOBSITE step and fell into opening of sewer manhole, right arm and shoulder injured

2018-13 JAMES BELLO TEAMSTER TRUCK DRIVER 2/12 JOBSITE location of 3rd street between smith st and hoxl st picking up tractor on back side of boom truck, tractor dislodged, came down and hit employee on back portion of leg

2018-14 ERIK PALMERI TEAMSTER TRUCK DRIVER 6/25 JOBSITE getting out of truck, step on piece of timber curb on the edge and rolled right ankle

2018-15 CASIMIRO QUINTERO CARPENTER 3/28 JOBSITE step and fell into opening of sewer manhole, right arm and shoulder injured

2018-16 JAMES BELLO TEAMSTER TRUCK DRIVER 2/12 JOBSITE location of 3rd street between smith st and hoxl st picking up tractor on back side of boom truck, tractor dislodged, came down and hit employee on back portion of leg

2018-17 ERIK PALMERI TEAMSTER TRUCK DRIVER 6/25 JOBSITE getting out of truck, step on piece of timber curb on the edge and rolled right ankle

2018-18 CASIMIRO QUINTERO CARPENTER 3/28 JOBSITE step and fell into opening of sewer manhole, right arm and shoulder injured

2018-19 JAMES BELLO TEAMSTER TRUCK DRIVER 2/12 JOBSITE location of 3rd street between smith st and hoxl st picking up tractor on back side of boom truck, tractor dislodged, came down and hit employee on back portion of leg

2018-20 ERIK PALMERI TEAMSTER TRUCK DRIVER 6/25 JOBSITE getting out of truck, step on piece of timber curb on the edge and rolled right ankle

2018-21 CASIMIRO QUINTERO CARPENTER 3/28 JOBSITE step and fell into opening of sewer manhole, right arm and shoulder injured

2018-22 JAMES BELLO TEAMSTER TRUCK DRIVER 2/12 JOBSITE location of 3rd street between smith st and hoxl st picking up tractor on back side of boom truck, tractor dislodged, came down and hit employee on back portion of leg

2018-23 ERIK PALMERI TEAMSTER TRUCK DRIVER 6/25 JOBSITE getting out of truck, step on piece of timber curb on the edge and rolled right ankle

Summary table with columns for Case, Employee's name, Job title, Date of injury, Where the event occurred, Describe injury or illness, Part of body affected, Death, Days away from work, Restricted at Work (Job transfer, Other records), Days lost from work, On job transfer or restriction, Injury, Skin disorder, Respiratory condition, Poisoning, Hearing loss, All other illnesses.

Public reporting burden for this collection of information is estimated to average 14 minutes per response, including time to review the final version, search the data needed, and complete and review the collection of information. Persons are not required to respond to the collection of information unless it displays a currently valid OMB control number. If you have any comments about these estimates or any other aspect of this data collection, contact: US Department of Labor, OSHA Office of Statistical Analysis, Room 4-3044, 200 Constitution Avenue, NW, Washington, DC 20210. Do not send the completed forms to this office.

Summary of Work-Related Injuries and Illnesses

Year 2018

U.S. Department of Labor
Occupational Safety and Health Administration
Form approved OMB no. 1218-0176

All establishments covered by Part 1904 must complete this Summary page, even if no work-related injuries or illnesses occurred during the year. Remember to review the Log to verify that the entries are complete and accurate before completing this summary.
Using the Log, count the individual entries you made for each category. Then write the totals below, making sure you've added the entries from every page of the Log. If you had no cases, write "0".
Employees, former employees, and their representatives have the right to review the OSHA Form 300 in its entirety. They also have limited access to the OSHA Form 301 or its equivalent. See 29 CFR Part 1904.35, in OSHA's recordkeeping rule, for further details on the access provisions for these forms.

Number of Cases

Total number of deaths	Total number of cases with days away from work	Total number of cases with job transfer or restriction	Total number of other recordable cases
0	2	0	0
(G)	(H)	(I)	(J)

Number of Days

Total number of days away from work	Total number of days of job transfer or restriction
243	0
(K)	(L)

Injury and Illness Types

Total number of...	(1) Injuries (M)	(2) Skin disorders	(3) Respiratory conditions	(4) Poisonings	(5) Hearing loss	(6) All other illnesses
	3	0	0	0	0	0

Post this Summary page from February 1 to April 30 of the year following the year covered by the form.

Public reporting burden for this collection of information is estimated to average 30 minutes per response, including time to review the instructions, search and gather the data needed, and complete and review the collection of information. Persons are not required to respond to the collection of information unless it displays a currently valid OMB control number. If you have any comments about these estimates or any other aspects of this data collection, contact: US Department of Labor, OSHA Office of Statistical Analysis, Room N-3641, 200 Constitution Avenue, NW, Washington, DC 20210. Do not send the completed forms to this office.

Establishment Information

Your establishment name **ADC CONSTRUCTION LLC**
 Street **58-08 48TH STREET**
 City **MASPETH** State **NY** ZIP **11378**

Industry description (e.g., *Manufacture of rubber truck trailers*)

Standard Industrial Classification (SIC), if known (e.g., 3715)

OR

North American Industrial Classification (NAICS), if known (e.g., 336212)

Employment Information (If you don't have these figures, see the Worksheet on the back of this page to estimate.)

Annual average number of employees **60**

Total hours worked by all employees last year **128991**

Sign here

Knowingly falsifying this document may result in a fine.

I certify that I have examined this document and that to the best of my knowledge the entries are true, accurate, and complete.

Michael Shradu
Project Manager

718, 628-5555

IRAN DIVESTMENT ACT COMPLIANCE RIDER

FOR NEW YORK CITY CONTRACTORS

The Iran Divestment Act of 2012, effective as of April 12, 2012, is codified at State Finance Law ("SFL") §165-a and General Municipal Law ("GML") §103-g. The Iran Divestment Act, with certain exceptions, prohibits municipalities, including the City, from entering into contracts with persons engaged in investment activities in the energy sector of Iran. Pursuant to the terms set forth in SFL §165-a and GML §103-g, a person engages in investment activities in the energy sector of Iran if:

- (a) The person provides goods or services of twenty million dollars or more in the energy sector of Iran, including a person that provides oil or liquefied natural gas tankers, or products used to construct or maintain pipelines used to transport oil or liquefied natural gas, for the energy sector of Iran; or
- (b) The person is a financial institution that extends twenty million dollars or more in credit to another person, for forty-five days or more, if that person will use the credit to provide goods or services in the energy sector in Iran and is identified on a list created pursuant to paragraph (b) of subdivision three of Section 165-a of the State Finance Law and maintained by the Commissioner of the Office of General Services.

A bid or proposal shall not be considered for award nor shall any award be made where the bidder or proposer fails to submit a signed and verified bidder's certification.

Each bidder or proposer must certify that it is not on the list of entities engaged in investment activities in Iran created pursuant to paragraph (b) of subdivision 3 of Section 165-a of the State Finance Law. In any case where the bidder or proposer cannot certify that they are not on such list, the bidder or proposer shall so state and shall furnish with the bid or proposal a signed statement which sets forth in detail the reasons why such statement cannot be made. The City of New York may award a bid to a bidder who cannot make the certification on a case by case basis if:

- (1) The investment activities in Iran were made before the effective date of this section (i.e., April 12, 2012), the investment activities in Iran have not been expanded or renewed after the effective date of this section and the person has adopted, publicized and is implementing a formal plan to cease the investment activities in Iran and to refrain from engaging in any new investments in Iran: or
- (2) The City makes a determination that the goods or services are necessary for the City to perform its functions and that, absent such an exemption, the City would be unable to obtain the goods or services for which the contract is offered. Such determination shall be made in writing and shall be a public document.

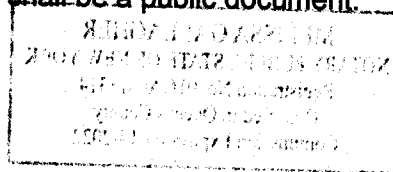

**BIDDER'S CERTIFICATION OF COMPLIANCE WITH
IRAN DIVESTMENT ACT**

Pursuant to General Municipal Law Section 103-g, which generally prohibits the City from entering into contracts with persons engaged in investment activities in the energy sector of Iran, the bidder/proposer submits the following certification:

[Please Check One]

BIDDER'S CERTIFICATION

- By submission of this bid or proposal, each bidder/proposer and each person signing on behalf of any bidder/proposer certifies, and in the case of a joint bid each party thereto certifies as to its own organization, under penalty of perjury, that to the best of its knowledge and belief, that each bidder/proposer is not on the list created pursuant to paragraph (b) of subdivision 3 of Section 165-a of the State Finance Law.
- I am unable to certify that my name and the name of the bidder/proposer does not appear on the list created pursuant to paragraph (b) of subdivision 3 of Section 165-a of the State Finance Law. I have attached a signed statement setting forth in detail why I cannot so certify.

Domenick Capolongo
SIGNATURE

DOMENICK CAPOLONGO
PRINTED NAME

PRESIDENT
TITLE

Sworn to before me this
12 day of Dec, 2019

Melissa Gallagher
Notary Public

Dated: 12/5/19

MELISSA GALLAGHER
NOTARY PUBLIC, STATE OF NEW YORK
Registration No. 01GA6013314
Qualified in Queens County
Commission Expires 09-14-2022

B. BID SCHEDULE (B-PAGES)

The following pages contain the Bid Schedule. Items listed in the Bid Schedule shall comply with the requirements of the corresponding sections of the specifications detailed in the table below. All references to the Standard Specifications, Details, Standards and Drawings shall be to the version in effect at the time of bid.

NOTES:

- "XXX" in the table below signifies any possible combination of characters and spaces.
- The table below may contain item formats which are not included in the Bid Schedule.
Please refer to the Bid Schedule to determine which specifications apply.

Item Number Format	Applicable Specifications
4.XXX 6.XXX 7.XXX 8.XXX (Except 8.01 XXX; see below) 9.XXX HW-XXX	NYC Department of Transportation ("DOT") Standard Highway Specifications, as amended in the R-Pages, located in Volume 3 of 3 herein; <p style="text-align: center;">AND</p> NYC DOT Standard Details of Construction; <p style="text-align: center;">OR,</p> <i>if the item is not contained within the Standard Specifications, then see the applicable New Sections in the I-Pages, located in Volume 3 of 3 herein.</i>
1.XXX 50.XXX through 55.XXX 60.XXX through 66.XXX 70.XXX through 79.XXX (Except 79.11XXX; see below) DSS XXX DSW XXX	NYC Department of Environmental Protection ("DEP") Standard Sewer and Water Main Specifications, as amended in the R-Pages and SW-Pages, located in Volume 3 of 3 herein; <p style="text-align: center;">AND</p> NYC DEP Specifications for Trunk Main Work; <p style="text-align: center;">AND</p> NYC DEP Sewer Design Standards; <p style="text-align: center;">AND</p> NYC DEP Water Main Standard Drawings; <p style="text-align: center;">OR,</p> <i>if the item is not contained within the Standard Specifications, then see the Amendments to the Standard Sewer and Water Main Specifications in the SW-Pages, located in Volume 3 of 3 herein.</i>
GI-XXX PM-XXX ROW XXX	New Sections in the I-Pages, located in Volume 3 of 3 herein <p style="text-align: center;">AND</p> NYC DEP Standards for Green Infrastructure.
UTL-XXX	Gas Cost Sharing Standard Specifications in the EP7-Pages, located in Volume 3 of 3 herein.

Item Number Format	Applicable Specifications
83X.XXX MX.XXX MP XXX NYC-XXX NYCT-XXX NYPD-XXX P XXX PK-XXX	New Sections in the I-Pages, located in Volume 3 of 3 herein.
BMP-XXX	Specifications for Construction of Best Management Practice (BMP) and Mitigation Area in the BMP-Pages, located in Volume 3 of 3 herein.
E XXX ME XXX	Specifications for the Specialty Electrical Works in the EL-Pages, located in Volume 3 of 3 herein.
SL-XXX	NYC DOT Division of Street Lighting Specifications AND NYC Division of Street Lighting Standard Drawings.
T-XXX	NYC DOT Specifications for Traffic Signals and Intelligent Transportation Systems AND NYC DOT Traffic Signal Standard Drawings.
JB XXX	Joint Bid Specifications in the JB-Pages, located in Volume 3 of 3 herein.
8.01 XXX	Specifications for Handling, Transportation and Disposal of Nonhazardous and Potentially Hazardous Contaminated Materials in the HAZ-Pages, located in Volume 3 of 3 herein.
67.XXX	Specifications for Abatement of Coal Tar Wrap Asbestos Containing Materials in the ASB-Pages, located in Volume 3 of 3 herein.
79.11XXX	Specifications for Abatement of Transit Authority Duct Insulation Asbestos Containing Materials in the ASB-Pages, located in Volume 3 of 3 herein.

(NO FURTHER TEXT ON THIS PAGE)



Department of
Design and
Construction

10/3/2019 11:08 AM

NEW YORK CITY DEPARTMENT OF DESIGN AND CONSTRUCTION
DIVISION OF INFRASTRUCTURE - BUREAU OF DESIGN

CONTRACT PIN: 8502019SE0033C

PROJECT ID: SEQBN11

REBID: N/A

BID SCHEDULE

NOTE: (1) The Agency may reject a bid if it contains unbalanced bid prices. An unbalanced bid is considered to be one containing lump sum or unit items which do not reflect reasonable actual costs plus a reasonable proportionate share of the Bidder's anticipated profit, overhead costs, and other indirect costs, anticipated for the performance of the items in question.

(2) The following bid prices on Unit Price Contracts are to be paid for the actual quantities of the item numbers in the completed work or structure, and they cover the cost of all work, labor, material, tools, plant and appliances of every description necessary to complete the entire work, as specified, and the removal of all debris, temporary work and appliances.

(3) **PLEASE BE SURE A LEGIBLE BID IS ENTERED, IN INK, FOR EACH ITEM.**
Alterations must be initialed in ink by the bidder.

(4) The Extended Amount entered in Column 6 shall be the product of the Estimated Quantity in Column 3 times the Unit Price Bid in Column 5.

(5) Prospective bidders must examine the Bid Schedule carefully and, before bidding, must advise the Commissioner, in writing, if any pages are missing, and must request that such missing pages be furnished them. The pages of this Bid Schedule are numbered consecutively, as follows:
B - 3 Through B - 29

**PLEASE BE SURE A LEGIBLE BID IS ENTERED FOR EACH ITEM.
THE BIDDER SHALL INSERT THE TOTAL BID PRICE IN
THE BID FORM IN THIS BID BOOKLET.**

BID SCHEDULE FORM

10/3/2019 11:08 AM

SECTION	ITEM NUMBER AND DESCRIPTION	ESTIMATED QUANTITY	UNIT	UNIT PRICE	TOTAL PRICE
001	1.A08 8" E.S.V.P. SEWER, ON CONCRETE CRADLE (MINIMUM 15 FEET LENGTHS) Unit price bid shall not be less than: \$ 325.00	60.00	L.F.	325.00	19,500.00
002	1.A48 48" R.C.P. CLASS III SEWER, ON CONCRETE CRADLE (MINIMUM 15 FEET LENGTHS) Unit price bid shall not be less than: \$ 525.00	30.00	L.F.	525.00	15,750.00
003	1.B08 8" E.S.V.P. SEWER, ON CONCRETE CRADLE (ADDITIONAL LENGTH BEYOND THE MINIMUM 15 FEET) (FIXED UNIT PRICE TO BE 70% OF UNIT PRICE BID FOR ITEM NO. 1.A08)	110.00	L.F.	227.50	25,025.00
004	1.B48 48" R.C.P. CLASS III SEWER, ON CONCRETE CRADLE (ADDITIONAL LENGTH BEYOND THE MINIMUM 15 FEET TO A MAXIMUM OF 100 FEET) (FIXED UNIT PRICE TO BE 72% OF UNIT PRICE BID FOR ITEM NO. 1.A48)	55.00	L.F.	378.00	20,790.00
005	1.C10 10" E.S.V.P. SEWER, ON CONCRETE CRADLE (MINIMUM 15 FEET LENGTHS) Unit price bid shall not be less than: \$ 375.00	70.00	L.F.	375.00	26,250.00
006	1.C48 48" R.C.P. CLASS III SEWER, ON CONCRETE CRADLE (ADDITIONAL LENGTH BEYOND 100 FEET) (FIXED UNIT PRICE TO BE 65% OF UNIT PRICE BID FOR ITEM NO. 1.A48)	30.00	L.F.	341.25	10,237.50



Department of
Design and
Construction

10/3/2019 11:08 AM

NEW YORK CITY DEPARTMENT OF DESIGN AND CONSTRUCTION
DIVISION OF INFRASTRUCTURE - BUREAU OF DESIGN

PROJECT ID: SEQBN11
CONTRACT PIN: 8502019SE0033C
REBID: N/A

BID SCHEDULE FORM

Item No.	Description	Unit	Quantity	Unit Price	Total Price
007	1.D10 10" E.S.V.P. SEWER, ON CONCRETE CRADLE (ADDITIONAL LENGTH BEYOND THE MINIMUM 15 FEET TO A MAXIMUM OF 100 FEET) (FIXED UNIT PRICE TO BE 70% OF UNIT PRICE BID FOR ITEM NO. 1.C10)	L.F.	262.50	110.00	28,875.00
008	1.E10 10" E.S.V.P. SEWER, ON CONCRETE CRADLE (ADDITIONAL LENGTH BEYOND 100 FEET) (FIXED UNIT PRICE TO BE 63% OF UNIT PRICE BID FOR ITEM NO. 1.C10)	L.F.	236.25	170.00	40,162.50
009	1.F12 12" E.S.V.P. SEWER, ON CONCRETE CRADLE (MINIMUM 15 FEET LENGTHS) Unit price bid shall not be less than: \$ 437.50	L.F.	905.00	380.00	343,900.00
010	1.G12 12" E.S.V.P. SEWER, ON CONCRETE CRADLE (ADDITIONAL LENGTH BEYOND THE MINIMUM 15 FEET TO A MAXIMUM OF 100 FEET) (FIXED UNIT PRICE TO BE 70% OF UNIT PRICE BID FOR ITEM NO. 1.F12)	L.F.	633.50	1,720.00	1,089,620.00
011	1.H12 12" E.S.V.P. SEWER, ON CONCRETE CRADLE (ADDITIONAL LENGTH BEYOND 100 FEET) (FIXED UNIT PRICE TO BE 63% OF UNIT PRICE BID FOR ITEM NO. 1.F12)	L.F.	570.15	4,250.00	2,423,137.50
012	1.I15 15" E.S.V.P. SEWER, ON CONCRETE CRADLE (MINIMUM 15 FEET LENGTHS) Unit price bid shall not be less than: \$ 450.00	L.F.	1067.00	110.00	117,370.00

BID SCHEDULE FORM

SECTION	ITEM NUMBER AND DESCRIPTION	COLLECTOR ENGINEERS ESTIMATE OF QUANTITY	UNIT	ESTIMATE	EXTENSION
013	1.J15 15" E.S.V.P. SEWER, ON CONCRETE CRADLE (ADDITIONAL LENGTH BEYOND THE MINIMUM 15 FEET TO A MAXIMUM OF 100 FEET) (FIXED UNIT PRICE TO BE 70% OF UNIT PRICE BID FOR ITEM NO. 1.115)	430.00	L.F.	746 90	321,167 00
014	1.K15 15" E.S.V.P. SEWER, ON CONCRETE CRADLE (ADDITIONAL LENGTH BEYOND 100 FEET) (FIXED UNIT PRICE TO BE 63% OF UNIT PRICE BID FOR ITEM NO. 1.115)	1,100.00	L.F.	672 21	739,431 00
015	1.L18 18" E.S.V.P. SEWER, ON CONCRETE CRADLE (MINIMUM 15 FEET LENGTHS) Unit price bid shall not be less than: \$ 475.00	60.00	L.F.	970 00	58,200 00
016	1.M18 18" E.S.V.P. SEWER, ON CONCRETE CRADLE (ADDITIONAL LENGTH BEYOND THE MINIMUM 15 FEET TO A MAXIMUM OF 100 FEET) (FIXED UNIT PRICE TO BE 70% OF UNIT PRICE BID FOR ITEM NO. 1.118)	110.00	L.F.	679 00	74,690 00
017	1.N18 18" E.S.V.P. SEWER, ON CONCRETE CRADLE (ADDITIONAL LENGTH BEYOND 100 FEET) (FIXED UNIT PRICE TO BE 63% OF UNIT PRICE BID FOR ITEM NO. 1.118)	130.00	L.F.	611 10	79,443 00
018	1.O24 24" R.C.P. CLASS III SEWER, ON CONCRETE CRADLE (MINIMUM 15 FEET LENGTHS) Unit price bid shall not be less than: \$ 487.50	35.00	L.F.	1130 00	39,550 00



Department of
Design and
Construction

10/3/2019 11:08 AM

NEW YORK CITY DEPARTMENT OF DESIGN AND CONSTRUCTION PROJECT ID: SEQBN11
DIVISION OF INFRASTRUCTURE - BUREAU OF DESIGN CONTRACT PIN: 8502019SE0033C

REBID: N/A

BID SCHEDULE FORM

SECTION	ITEM NUMBER AND DESCRIPTION	COL 3 ENGINEER'S ESTIMATE OF QUANTITY	UNIT	PRICE	EXTENDED PRICE
019	1.P24 24" R.C.P. CLASS III SEWER, ON CONCRETE CRADLE (ADDITIONAL LENGTH BEYOND THE MINIMUM 15 FEET TO A MAXIMUM OF 100 FEET) (FIXED UNIT PRICE TO BE 72% OF UNIT PRICE BID FOR ITEM NO. 1.024)	35.00	L.F.	813	28,476.00
020	1.Q24 24" R.C.P. CLASS III SEWER, ON CONCRETE CRADLE (ADDITIONAL LENGTH BEYOND 100 FEET) (FIXED UNIT PRICE TO BE 65% OF UNIT PRICE BID FOR ITEM NO. 1.024)	60.00	L.F.	734	44,070.00
021	1.R30 30" R.C.P. CLASS III SEWER, ON CONCRETE CRADLE (MINIMUM 15 FEET LENGTHS) Unit price bid shall not be less than: \$ 500.00	35.00	L.F.	500	17,500.00
022	1.S30 30" R.C.P. CLASS III SEWER, ON CONCRETE CRADLE (ADDITIONAL LENGTH BEYOND THE MINIMUM 15 FEET TO A MAXIMUM OF 100 FEET) (FIXED UNIT PRICE TO BE 72% OF UNIT PRICE BID FOR ITEM NO. 1.R30)	55.00	L.F.	360	19,800.00
023	1.T30 30" R.C.P. CLASS III SEWER, ON CONCRETE CRADLE (ADDITIONAL LENGTH BEYOND 100 FEET) (FIXED UNIT PRICE TO BE 65% OF UNIT PRICE BID FOR ITEM NO. 1.R30)	35.00	L.F.	325	11,375.00
024	1.U36 36" R.C.P. CLASS III SEWER, ON CONCRETE CRADLE (MINIMUM 15 FEET LENGTHS) Unit price bid shall not be less than: \$ 512.50	30.00	L.F.	512	15,375.00

BID SCHEDULE FORM

SEQ. NO.	ITEM NUMBER and DESCRIPTION	ENGINEERS ESTIMATE OF QUANTITY	UNIT	COLL. UNIT PRICE (DOLLARS)	EXTENDED AMOUNT (DOLLARS)	QTS
025	1.V36 36" R.C.P. CLASS III SEWER, ON CONCRETE CRADLE (ADDITIONAL LENGTH BEYOND THE MINIMUM 15 FEET TO A MAXIMUM OF 100 FEET) (FIXED UNIT PRICE TO BE 72% OF UNIT PRICE BID FOR ITEM NO. 1.U36)	55.00	L.F.	369.00	20,295.00	
026	1.W36 36" R.C.P. CLASS III SEWER, ON CONCRETE CRADLE (ADDITIONAL LENGTH BEYOND 100 FEET) (FIXED UNIT PRICE TO BE 65% OF UNIT PRICE BID FOR ITEM NO. 1.U36)	30.00	L.F.	333.13	9993.90	
027	1.X42 42" R.C.P. CLASS III SEWER, ON CONCRETE CRADLE (MINIMUM 15 FEET LENGTHS) Unit price bid shall not be less than: \$ 525.00	30.00	L.F.	525.00	15,750.00	
028	1.Y42 42" R.C.P. CLASS III SEWER, ON CONCRETE CRADLE (ADDITIONAL LENGTH BEYOND THE MINIMUM 15 FEET TO A MAXIMUM OF 100 FEET) (FIXED UNIT PRICE TO BE 72% OF UNIT PRICE BID FOR ITEM NO. 1.X42)	55.00	L.F.	378.00	20,790.00	
029	1.Z42 42" R.C.P. CLASS III SEWER, ON CONCRETE CRADLE (ADDITIONAL LENGTH BEYOND 100 FEET) (FIXED UNIT PRICE TO BE 65% OF UNIT PRICE BID FOR ITEM NO. 1.X42)	30.00	L.F.	341.25	10,237.50	
030	4.02 CA BINDER MIXTURE	70.00	TONS	5.00	350.00	



Department of
Design and
Construction

NEW YORK CITY DEPARTMENT OF DESIGN AND CONSTRUCTION
DIVISION OF INFRASTRUCTURE - BUREAU OF DESIGN

PROJECT ID: SEQBN11

CONTRACT PIN: 8502019SE0033C

REBID: N/A

10/3/2019 11:08 AM

BID SCHEDULE FORM

COL 1 ITEM NUMBER	COL 2 ITEM DESCRIPTION	COL 3 ENGINEER ESTIMATE	COL 4 UNIT	COL 5 ESTIMATE	COL 6 TOTAL
031	4.02 CB ASPHALTIC CONCRETE MIXTURE Unit price bid shall not be less than: \$ 70.00	2,200.00	TONS	70 00	154,000 00
032	4.04 H CONCRETE BASE FOR PAVEMENT, VARIABLE THICKNESS FOR TRENCH RESTORATION, (HIGH-EARLY STRENGTH)	55.00	C.Y.	150 00	8,250 00
033	4.08 AA CONCRETE CURB (18" DEEP)	50.00	L.F.	15 00	750 00
034	4.09 AD STRAIGHT STEEL FACED CONCRETE CURB (18" DEEP)	50.00	L.F.	25 00	1250 00
035	4.13 AAS 4" CONCRETE SIDEWALK (UNPIGMENTED)	240.00	S.F.	4 00	960 00
036	4.13 BAS 7" CONCRETE SIDEWALK (UNPIGMENTED)	380.00	S.F.	6 00	2280 00
037	4.16 AA TREES REMOVED (4" TO UNDER 12" CALIPER)	4.00	EACH	100 00	400 00
038	4.16 AB TREES REMOVED (12" TO UNDER 18" CALIPER)	2.00	EACH	115 00	230 00



10/3/2019 11:08 AM

REBID: N/A

BID SCHEDULE FORM

COL 1 SEQ NO	COL 2 ITEM NUMBER and DESCRIPTION	COL 3 ENGINEER ESTIMATE OF QUANTITY	COL 4 UNITS	COL 5 UNIT PRICE (IN DOLLARS)	COL 6 TOTAL PRICE (IN DOLLARS)	COL 7 DETAILS	COL 8 REMARKS
039	4.16 AC TREES REMOVED (18" TO UNDER 24" CALIPER)	2.00	EACH	128.00	256.00		
040	4.16 AD TREES REMOVED (24" CALIPER AND OVER)	2.00	EACH	150.00	300.00		
041	4.16 CA405 TREES PLANTED, 3" TO 3-1/2" CALIPER, ALL TYPES, IN 4' X 5' TREE PITS	6.00	EACH	750.00	4500.00		
042	4.18 A MAINTENANCE TREE PRUNING (UNDER 12" CAL.)	5.00	EACH	150.00	750.00		
043	4.18 B MAINTENANCE TREE PRUNING (12" TO UNDER 18" CAL.)	3.00	EACH	200.00	600.00		
044	4.18 C MAINTENANCE TREE PRUNING (18" TO UNDER 24" CAL.)	3.00	EACH	250.00	750.00		
045	4.18 D MAINTENANCE TREE PRUNING (24" CAL. AND OVER)	2.00	EACH	300.00	600.00		
046	51.21S0A1000V STANDARD MANHOLE TYPE A-1	70.00	EACH	1000.00	70,000.00		



Department of
Design and
Construction

NEW YORK CITY DEPARTMENT OF DESIGN AND CONSTRUCTION
DIVISION OF INFRASTRUCTURE - BUREAU OF DESIGN

PROJECT ID: SEQBN11
CONTRACT PIN: 8502019SE0033C
REBID: N/A

10/3/2019 11:08 AM

BID SCHEDULE FORM

SEQ NO	ITEM NUMBER AND DESCRIPTION	QUANTITY	UNIT	ESTIMATE	AMOUNT	TOTAL AMOUNT
047	51.21S0A2000V STANDARD MANHOLE TYPE A-2	20.00	EACH		500.00	10,000.00
048	51.21S0B1000V STANDARD MANHOLE TYPE B-1	1.00	EACH		500.00	500.00
049	51.21S0B2000V STANDARD MANHOLE TYPE B-2	1.00	EACH		500.00	500.00
050	51.21S0C1000E STANDARD MANHOLE TYPE C-1 ON EXISTING SEWER	1.00	EACH		500.00	500.00
051	51.21S0C2000E STANDARD MANHOLE TYPE C-2 ON EXISTING SEWER	1.00	EACH		500.00	500.00
052	51.23RF REPLACEMENT OF EXISTING MANHOLE FRAME AND COVER	1.00	EACH		500.00	500.00
053	51.31S00100E STANDARD DROP-PIPE MANHOLE TYPE I ON EXISTING SEWER	1.00	EACH		500.00	500.00
054	51.41S001 STANDARD CATCH BASIN, TYPE 1	20.00	EACH		500.00	10,000.00

BID SCHEDULE FORM

COL 1 SEQ. NO.	COL 2 ITEM NUMBER and DESCRIPTION	ENGINEER'S ESTIMATE OF QUANTITY	UNIT	COL 3 UNIT PRICE (IN DOLLARS)	EST. AMOUNT (IN DOLLARS)	CTS
055	51.71M00000 MODIFICATION OF EXISTING MANHOLE	1.00	EACH	500.00	500.00	
056	52.11D12 12" DUCTILE IRON PIPE BASIN CONNECTION	360.00	L.F.	10.00	3600.00	
057	52.11D12C 12" DUCTILE IRON PIPE BASIN CONNECTION (CHUTE CONNECTION WORK ONLY)	105.00	L.F.	10.00	1050.00	
058	52.11D12D 12" DUCTILE IRON PIPE BASIN CONNECTION FOR MODIFICATION AND/OR REPLACEMENT OF CATCH BASINS	25.00	L.F.	10.00	250.00	
059	52.11V12 12" EXTRA STRENGTH VITRIFIED PIPE BASIN CONNECTION	25.00	L.F.	10.00	250.00	
060	52.11V12C 12" EXTRA STRENGTH VITRIFIED PIPE BASIN CONNECTION (CHUTE CONNECTION WORK ONLY)	25.00	L.F.	10.00	250.00	
061	52.11V12D 12" EXTRA STRENGTH VITRIFIED PIPE BASIN CONNECTION FOR MODIFICATION AND/OR REPLACEMENT OF CATCH BASINS	25.00	L.F.	10.00	250.00	
062	52.21V08 8" E.S.V.P. RISER FOR HOUSE CONNECTION	5.00	V.F.	5.00	25.00	



Department of
Design and
Construction

NEW YORK CITY DEPARTMENT OF DESIGN AND CONSTRUCTION PROJECT ID: SEQBN11
DIVISION OF INFRASTRUCTURE - BUREAU OF DESIGN CONTRACT PIN: 8502019SE0033C

10/3/2019 11:08 AM

REBID: N/A

BID SCHEDULE FORM

SEQ. NO.	ITEM NUMBER AND DESCRIPTION	CCU ENGINEER'S ESTIMATE OF QUANTITY	UNIT	UNIT PRICE	EXTENDED AMOUNT
063	52.21V10 10" E.S.V.P. RISER FOR HOUSE CONNECTION	5.00	V.F.	5.00	25.00
064	52.31V06P00 6" E.S.V.P. SPUR FOR HOUSE CONNECTION ON E.S.V.P. SEWER	15.00	EACH	5.00	75.00
065	52.31V08P00 8" E.S.V.P. SPUR FOR HOUSE CONNECTION ON E.S.V.P. SEWER	10.00	EACH	5.00	50.00
066	52.41D06N NEW 6" D.I.P. HOUSE CONNECTION DRAIN ON STONE BEDDING Unit price bid shall not be greater than: \$ 75.00	45.00	L.F.	75.00	3375.00
067	52.41D06R 6" D.I.P. HOUSE CONNECTION DRAIN ON CONCRETE CRADLE (RECONNECTION)	45.00	L.F.	75.00	3375.00
068	52.41V06N NEW 6" E.S.V.P. HOUSE CONNECTION DRAIN ON CONCRETE CRADLE Unit price bid shall not be greater than: \$ 75.00	45.00	L.F.	75.00	3375.00
069	52.41V06R 6" E.S.V.P. HOUSE CONNECTION DRAIN ON CONCRETE CRADLE (RECONNECTION)	45.00	L.F.	50.00	2250.00

REBID: N/A

10/3/2019 11:08 AM

BID SCHEDULE FORM

COL 1 SEQ. NO.	COL 2 ITEM NUMBER AND DESCRIPTION	COL 3 ENGINEER'S ESTIMATE OF QUANTITY	COL 4 UNIT	COL 5 UNIT PRICE (IN FIGURES)	COL 6 EXTENDED AMT. (IN FIGURES)
070	53.11DR TELEVISION INSPECTION AND DIGITAL AUDIO-VISUAL RECORDING OF SEWERS	9,500.00	L.F.	4.00	38,000.00
071	6.43 D DIGITAL PHOTOGRAPHS	4,000.00	SETS	7.00	28,000.00
072	6.70 MAINTENANCE AND PROTECTION OF TRAFFIC Unit price bid shall not be less than: \$ 95,000.00	1.00	L.S.	95,000.00	95,000.00
073	60.11R520 FURNISHING AND DELIVERING 20-INCH DUCTILE IRON RESTRAINED JOINT PIPE (CLASS 55)	55.00	L.F.	135.00	7425.00
074	60.11R606 FURNISHING AND DELIVERING 6-INCH DUCTILE IRON RESTRAINED JOINT PIPE (CLASS 56)	105.00	L.F.	30.00	3150.00
075	60.11R608 FURNISHING AND DELIVERING 8-INCH DUCTILE IRON RESTRAINED JOINT PIPE (CLASS 56)	210.00	L.F.	53.00	11,130.00
076	60.11R612 FURNISHING AND DELIVERING 12-INCH DUCTILE IRON RESTRAINED JOINT PIPE (CLASS 56)	520.00	L.F.	70.00	36,400.00
077	60.12D06 LAYING 6-INCH DUCTILE IRON PIPE AND FITTINGS	110.00	L.F.	45.00	4950.00



Department of
Design and
Construction

NEW YORK CITY DEPARTMENT OF DESIGN AND CONSTRUCTION
DIVISION OF INFRASTRUCTURE - BUREAU OF DESIGN

PROJECT ID: SEQBN11
CONTRACT PIN: 8502019SE0033C

10/3/2019 11:08 AM

REBID: N/A

BID SCHEDULE FORM

COL 1 SEQ NO	COL 2 ITEM NUMBER AND DESCRIPTION	COL 3 ENGINEER'S ESTIMATE OF QUANTITY	COL 4 UNIT OF MEASURE	COL 5 UNIT PRICE	COL 6 TOTAL BID PRICE
078	60.12D08 LAYING 8-INCH DUCTILE IRON PIPE AND FITTINGS	220.00	L.F.	60.00	13,200.00
079	60.12D12 LAYING 12-INCH DUCTILE IRON PIPE AND FITTINGS	560.00	L.F.	75.80	42,000.00
080	60.12D20 LAYING 20-INCH DUCTILE IRON PIPE AND FITTINGS	55.00	L.F.	115.80	6,325.00
081	60.13M0A24 FURNISHING AND DELIVERING DUCTILE IRON MECHANICAL JOINT 24-INCH DIAMETER AND SMALLER FITTINGS, INCLUDING WEDGE TYPE RETAINER GLANDS	2.00	TONS	5800.00	11,600.00
082	61.11DMM06 FURNISHING AND DELIVERING 6-INCH MECHANICAL JOINT DUCTILE IRON GATE VALVE COMPLETE WITH WEDGE TYPE RETAINER GLANDS	2.00	EACH	275.00	550.00
083	61.11DMM08 FURNISHING AND DELIVERING 8-INCH MECHANICAL JOINT DUCTILE IRON GATE VALVE COMPLETE WITH WEDGE TYPE RETAINER GLANDS	4.00	EACH	250.00	1,000.00
084	61.11DMM12 FURNISHING AND DELIVERING 12-INCH MECHANICAL JOINT DUCTILE IRON GATE VALVE COMPLETE WITH WEDGE TYPE RETAINER GLANDS	5.00	EACH	400.00	2,000.00



10/3/2019 11:08 AM

BID SCHEDULE FORM

COL 1 SEQ. NO.	COL 2 ITEM NUMBER AND DESCRIPTION	COL 3 ENGINEERS ESTIMATE OF QUANTITY	COL 4 UNIT	COL 5 UNIT PRICE IN FOUR DECIMALS	COL 6 EXTENDING TOTAL FIGURE IN FIGURES	COL 7 TOTALS
085	61.11DMM20 FURNISHING AND DELIVERING 20-INCH MECHANICAL JOINT DUCTILE IRON GATE VALVE COMPLETE WITH WEDGE TYPE RETAINER GLANDS	1.00	EACH	450.00	450.00	
086	61.11TWC03 FURNISHING AND DELIVERING 3-INCH WET CONNECTION TAPPING VALVE COMPLETE WITH WEDGE TYPE RETAINER GLANDS	2.00	EACH	80.00	160.00	
087	61.11TWC04 FURNISHING AND DELIVERING 4-INCH WET CONNECTION TAPPING VALVE COMPLETE WITH WEDGE TYPE RETAINER GLANDS	2.00	EACH	80.00	160.00	
088	61.11TWC06 FURNISHING AND DELIVERING 6-INCH WET CONNECTION TAPPING VALVE COMPLETE WITH WEDGE TYPE RETAINER GLANDS	4.00	EACH	90.00	360.00	
089	61.11TWC08 FURNISHING AND DELIVERING 8-INCH WET CONNECTION TAPPING VALVE COMPLETE WITH WEDGE TYPE RETAINER GLANDS	5.00	EACH	90.00	450.00	
090	61.11TWC12 FURNISHING AND DELIVERING 12-INCH WET CONNECTION TAPPING VALVE COMPLETE WITH WEDGE TYPE RETAINER GLANDS	6.00	EACH	100.00	600.00	
091	61.12DMM06 SETTING 6-INCH MECHANICAL JOINT DUCTILE IRON GATE VALVE COMPLETE WITH WEDGE TYPE RETAINER GLANDS	2.00	EACH	10.00	20.00	
092	61.12DMM08 SETTING 8-INCH MECHANICAL JOINT DUCTILE IRON GATE VALVE COMPLETE WITH WEDGE TYPE RETAINER GLANDS	4.00	EACH	10.00	40.00	



Department of Design and Construction

NEW YORK CITY DEPARTMENT OF DESIGN AND CONSTRUCTION PROJECT ID: SEQBN11
DIVISION OF INFRASTRUCTURE - BUREAU OF DESIGN CONTRACT PIN: 8502019SE0033C

10/3/2019 11:08 AM

REBID: N/A

BID SCHEDULE FORM

COL 1 SEQNO	COL 2 ITEM NUMBER AND DESCRIPTION	COL 3 ENGINEERS ESTIMATE QUANTITY	COL 4 UNIT	COL 5 UNIT PRICE	COL 6 TOTAL PRICE
093	61.12DMM12 SETTING 12-INCH MECHANICAL JOINT DUCTILE IRON GATE VALVE COMPLETE WITH WEDGE TYPE RETAINER GLANDS	5.00	EACH	10 00	50 00
094	61.12DMM20 SETTING 20-INCH MECHANICAL JOINT DUCTILE IRON GATE VALVE COMPLETE WITH WEDGE TYPE RETAINER GLANDS	1.00	EACH	10 00	10 00
095	61.12TWC03 SETTING 3-INCH WET CONNECTION TAPPING VALVE COMPLETE WITH WEDGE TYPE RETAINER GLANDS	2.00	EACH	10 00	20 00
096	61.12TWC04 SETTING 4-INCH WET CONNECTION TAPPING VALVE COMPLETE WITH WEDGE TYPE RETAINER GLANDS	2.00	EACH	10 00	20 00
097	61.12TWC06 SETTING 6-INCH WET CONNECTION TAPPING VALVE COMPLETE WITH WEDGE TYPE RETAINER GLANDS	4.00	EACH	10 00	40 00
098	61.12TWC08 SETTING 8-INCH WET CONNECTION TAPPING VALVE COMPLETE WITH WEDGE TYPE RETAINER GLANDS	5.00	EACH	10 00	50 00
099	61.12TWC12 SETTING 12-INCH WET CONNECTION TAPPING VALVE COMPLETE WITH WEDGE TYPE RETAINER GLANDS	6.00	EACH	10 00	60 00
100	62.11SD FURNISHING AND DELIVERING HYDRANTS	5.00	EACH	300 00	1500 00

10/3/2019 11:08 AM

BID SCHEDULE FORM

SEQ. NO.	COL. 2 ITEM NUMBER AND DESCRIPTION	COL. 3 ENGINEER'S ESTIMATE OF QUANTITY	COL. 4 UNIT	COL. 5 UNIT PRICE (IN FIGURES) DOLLARS	COL. 6 EXTENDED AMOUNT (IN FIGURES) DOLLARS
101	62.12SG SETTING HYDRANTS COMPLETE WITH WEDGE TYPE RETAINER GLANDS	5.00	EACH	10.00	50.00
102	62.13RH REMOVING HYDRANTS	5.00	EACH	10.00	50.00
103	62.14FS FURNISHING, DELIVERING AND INSTALLING HYDRANT FENDERS	10.00	EACH	10.00	100.00
104	63.11VC FURNISHING AND DELIVERING VARIOUS CASTINGS	4.00	TONS	10.00	40.00
105	64.11EL WITHDRAWING AND REPLACING HOUSE SERVICES USING 1-1/2- INCH OR LARGER SCREW TAPS	2.00	EACH	250.00	500.00
106	64.11ST WITHDRAWING AND REPLACING HOUSE SERVICES USING SMALLER THAN 1-1/2-INCH SCREW TAPS	10.00	EACH	100.00	1000.00
107	64.12COEG CUTTING AND OFFSETTING HOUSE SERVICE WATER CONNECTIONS (EQUAL TO OR GREATER THAN 3-INCH DIAMETER)	55.00	L.F.	25.00	1375.00
108	64.12COLT CUTTING AND OFFSETTING HOUSE SERVICE WATER CONNECTIONS (LESS THAN 3-INCH DIAMETER)	105.00	L.F.	10.00	1050.00



Department of
Design and
Construction

10/3/2019 11:08 AM

NEW YORK CITY DEPARTMENT OF DESIGN AND CONSTRUCTION
DIVISION OF INFRASTRUCTURE - BUREAU OF DESIGN

PROJECT ID: SEQBN11
CONTRACT PIN: 8502019SE0033C

REBID: N/A

BID SCHEDULE FORM

COL SEQ. NO.	COL 2 ITEM NUMBER AND DESCRIPTION	ENGINEER ESTIMATE OF QUANTITY	COL 3 UNIT	COL 4 ESTIMATED QUANTITY	COL 5 ESTIMATED PRICE	COL 6 TOTAL ESTIMATED PRICE
109	64.12ESEG EXTENDING HOUSE SERVICE WATER CONNECTIONS (EQUAL TO OR GREATER THAN 3-INCH DIAMETER)	105.00	L.F.	25.00	2625.00	
110	64.12ESLT EXTENDING HOUSE SERVICE WATER CONNECTIONS (LESS THAN 3- INCH DIAMETER)	210.00	L.F.	5.00	1050.00	
111	64.13WC08 FURNISHING, DELIVERING AND INSTALLING WET CONNECTION SLEEVE ON 8-INCH WATER MAIN PIPE WITH VARIOUS OUTLETS	5.00	EACH	100.00	500.00	
112	64.13WC12 FURNISHING, DELIVERING AND INSTALLING WET CONNECTION SLEEVE ON 12-INCH WATER MAIN PIPE WITH VARIOUS OUTLETS	5.00	EACH	100.00	500.00	
113	64.13WC20 FURNISHING, DELIVERING AND INSTALLING WET CONNECTION SLEEVE ON 20-INCH WATER MAIN PIPE WITH VARIOUS OUTLETS	1.00	EACH	200.00	200.00	
114	65.11BR FURNISHING, DELIVERING AND INSTALLING BANDS, RODS, WASHERS, ETC., COMPLETE, FOR RESTRAINING JOINTS	1,150.00	LBS.	1.00	1150.00	
115	65.21PS FURNISHING AND PLACING POLYETHYLENE SLEEVE Unit price bid shall not be less than: \$ 2.00	275.00	L.F.	2.00	550.00	

BID SCHEDULE FORM

COL 1 SEQ. NO.	COL 2 ITEM NUMBER and DESCRIPTION	COL 3 ENGINEER'S ESTIMATE OF QUANTITY	COL 4 U.N.I.T.	COL 5 UNIT PRICE (IN FIGURES) DOLLARS PER UNIT	COL 6 EXTENDED AMOUNT IN FIGURES DOLLARS	COL 7 GTS
116	65.31FF FURNISHING, DELIVERING AND PLACING FILTER FABRIC Unit price bid shall not be less than: \$ 0.10	1,150.00	S.F.	0.10	115.00	
117	65.71SG FURNISHING, DELIVERING AND PLACING SCREENED GRAVEL OR SCREENED BROKEN STONE BEDDING	10.00	C.Y.	5.00	50.00	
118	7.13 A MAINTENANCE OF SITE Unit price bid shall not be less than: \$ 90,000.00	1.00	L.S.	90,000.00	90,000.00	
119	70.21DK DECKING	110.00	S.Y.	15.00	1650.00	
120	70.31FN FENCING Unit price bid shall not be less than: \$ 1.50	18,000.00	L.F.	1.50	27,000.00	
121	70.51EO EXCAVATION OF BOULDERS IN OPEN CUT Unit price bid shall not be less than: \$ 45.00	50.00	C.Y.	150.00	7500.00	



Department of
Design and
Construction

NEW YORK CITY DEPARTMENT OF DESIGN AND CONSTRUCTION
DIVISION OF INFRASTRUCTURE - BUREAU OF DESIGN

PROJECT ID: SEQBN11
CONTRACT PIN: 8502019SE0033C
REBID: N/A

10/3/2019 11:08 AM

BID SCHEDULE FORM

COL 1 SEQ NO	COL 2 ITEM NUMBER AND DESCRIPTION	COL 3 ENGINEER ESTIMATE OF QUANTITY	COL 4 UNIT PRICE	COL 5 EXTENDING AMOUNT IN DOLLARS
122	70.61RE ROCK EXCAVATION	40.00 C.Y.	25.00	1000.00
123	70.71SB STONE BALLAST Unit price bid shall not be less than: \$ 15.00	40.00 C.Y.	85.00	3400.00
124	70.91SW12 FURNISHING AND PLACING SHEETING AND BRACING IN TRENCH FOR WATER MAIN PIPE 12-INCH IN DIAMETER AND LESS	290.00 S.F.	0.02	5.80
125	70.91SW20 FURNISHING AND PLACING SHEETING AND BRACING IN TRENCH FOR WATER MAIN PIPE 20-INCH IN DIAMETER	500.00 S.F.	0.04	20.00
126	73.11AB ADDITIONAL BRICK MASONRY Unit price bid shall not be less than: \$ 50.00	5.00 C.Y.	50.00	250.00
127	73.21AC ADDITIONAL CONCRETE Unit price bid shall not be less than: \$ 50.00	50.00 C.Y.	50.00	2500.00

10/3/2019 11:08 AM

REBID: N/A

BID SCHEDULE FORM

COL 1 SEQ. NO.	COL 2 ITEM NUMBER AND DESCRIPTION	COL 3 ENGINEERS ESTIMATE OF QUANTITY	COL 4 C.Y.	COL 5 UNIT PRICE (IN FIGURES)	COL 6 EXTENDED AMOUNT (IN FIGURES)	COL 7 DOLLARS	COL 8 C.Y.	COL 9 DOLLARS
128	73.31AE2 ADDITIONAL EARTH EXCAVATION INCLUDING TEST PITS (OVER 12' TO 16' DEPTH) Unit price bid shall not be less than: \$ 15.00	420.00	C.Y.	231.00	97,020.00			
129	73.31AE3 ADDITIONAL EARTH EXCAVATION INCLUDING TEST PITS (OVER 16' TO 20' DEPTH) Unit price bid shall not be less than: \$ 20.00	105.00	C.Y.	20.00	2,100.00			
130	73.31AE4 ADDITIONAL EARTH EXCAVATION INCLUDING TEST PITS (OVER 20' TO 24' DEPTH) Unit price bid shall not be less than: \$ 30.00	50.00	C.Y.	30.00	1,500.00			
131	73.31AE5 ADDITIONAL EARTH EXCAVATION INCLUDING TEST PITS (OVER 24' DEPTH) Unit price bid shall not be less than: \$ 37.50	50.00	C.Y.	37.50	1,875.00			
132	73.41AG ADDITIONAL SELECT GRANULAR BACKFILL Unit price bid shall not be less than: \$ 12.50	5,500.00	C.Y.	26.00	143,000.00			
133	73.51AS ADDITIONAL STEEL REINFORCING BARS Unit price bid shall not be less than: \$ 1.00	1,100.00	LBS.	1.00	1,100.00			



Department of
Design and
Construction

NEW YORK CITY DEPARTMENT OF DESIGN AND CONSTRUCTION
DIVISION OF INFRASTRUCTURE - BUREAU OF DESIGN

PROJECT ID: SEQBN11

CONTRACT PIN: 8502019SE0033C

10/3/2019 11:08 AM

REBID: N/A

BID SCHEDULE FORM

COL 1 SEQ NO	COL 2 ITEM NUMBER AND DESCRIPTION	COL 3 ENGINEER'S ESTIMATE QUANTITY	COL 4 UNIT	COL 5 UNIT PRICE (L.C.P.)	COL 6 TOTAL PRICE (L.C.P.)	COL 7 TENDER VOUCHER NO.
134	75.11RT REMOVAL OF ABANDONED TRACKS	220.00	L.F.	5.00	1100.00	
135	9.29 ALLOWANCE FOR RAILROAD FACILITIES INCLUDING INSURANCE AND FORCE ACCOUNT (ALL TYPES) PRICE BID SHALL BE FOR THE FIXED SUM OF \$ 80,000.00	1.00	F.S.	80,000.00	\$80,000.00	
136	DSS006A TREE CONSULTANT	250.00	P/HR	5.00	1250.00	
137	DSS008A MOBILIZATION (DEWATERING)	2.00	EACH	5.00	10.00	
138	DSS008B HEADER AND DISCHARGE PIPE INSTALLATION	80.00	L.F.	5.00	400.00	
139	DSS008C HEADER AND DISCHARGE PIPE RENTAL	80.00	S/DAY	2.00	160.00	
140	DSS008D WELLPOINT INSTALLATION	10.00	EACH	5.00	50.00	

10/3/2019 11:08 AM

REBID: N/A

BID SCHEDULE FORM

COL 1 SEQ. NO.	COL 2 ITEM NUMBER and DESCRIPTION	ENGINEER'S ESTIMATE OF QUANTITY	UNIT	COL 5 UNIT PRICE (IN FIGURES)	COL 6 ESTIMATED AMOUNT (IN FIGURES)	COL 7 DOLLARS	COL 8 CENTS
141	DSS008E WELLPOINT RENTAL	80.00	E/DAY	5.00	400.00		
142	DSS008F SYSTEM OPERATION	55.00	HRS	5.00	275.00		
143	UTL-6.01.1 (CE) GAS MAIN CROSSING SEWER UP TO 24" IN DIAMETER (\$6.01) Unit price bid shall not be less than: \$ 1,040.00	2.00	EACH	1040.00	2080.00		
144	UTL-6.01.1 (NG) GAS MAIN CROSSING SEWER UP TO 24" IN DIAMETER (\$6.01) Unit price bid shall not be less than: \$ 1,040.00	30.00	EACH	1040.00	31,200.00		
145	UTL-6.01.2 (CE) GAS MAIN CROSSING SEWER 30" IN DIAMETER (\$6.01) Unit price bid shall not be less than: \$ 1,770.00	2.00	EACH	1770.00	3540.00		
146	UTL-6.01.2 (NG) GAS MAIN CROSSING SEWER 30" IN DIAMETER (\$6.01) Unit price bid shall not be less than: \$ 1,770.00	2.00	EACH	1770.00	3540.00		



Department of
Design and
Construction

10/3/2019 11:08 AM

NEW YORK CITY DEPARTMENT OF DESIGN AND CONSTRUCTION
DIVISION OF INFRASTRUCTURE - BUREAU OF DESIGN

PROJECT ID: SEQBN11

CONTRACT PIN: 8502019SE0033C

REBID: N/A

BID SCHEDULE FORM

COL 1 SEQ. NO.	COL 2 ITEM NUMBER AND DESCRIPTION	COL 3 ENGINEER'S ESTIMATE OF QUANTITY	COL 4 UNITS	COL 5 UNIT PRICE LIK FIGURES DOLLARS	COL 6 TOTAL EXTENDED AMOUNT DOLLARS
147	UTL-6.01.3 (CE) GAS MAIN CROSSING SEWER 36" THRU 42" IN DIAMETER (\$6.01) Unit price bid shall not be less than: \$ 2,040.00	2.00	EACH	2040.00	4080.00
148	UTL-6.01.3 (NG) GAS MAIN CROSSING SEWER 36" THRU 42" IN DIAMETER (\$6.01) Unit price bid shall not be less than: \$ 2,040.00	3.00	EACH	2040.00	6120.00
149	UTL-6.01.4 (CE) GAS MAIN CROSSING SEWER 48" THRU 54" IN DIAMETER (\$6.01) Unit price bid shall not be less than: \$ 2,120.00	2.00	EACH	2120.00	4240.00
150	UTL-6.01.4 (NG) GAS MAIN CROSSING SEWER 48" THRU 54" IN DIAMETER (\$6.01) Unit price bid shall not be less than: \$ 2,120.00	2.00	EACH	2120.00	4240.00
151	UTL-6.01.8 (CE) GAS SERVICES CROSSING TRENCHES AND/OR EXCAVATIONS (\$6.01) Unit price bid shall not be less than: \$ 465.00	2.00	EACH	465.00	930.00
152	UTL-6.01.8 (NG) GAS SERVICES CROSSING TRENCHES AND/OR EXCAVATIONS (\$6.01) Unit price bid shall not be less than: \$ 465.00	400.00	EACH	465.00	186,000.00

10/3/2019 11:08 AM

REBID: N/A

BID SCHEDULE FORM

COL 1 SEQ. NO.	COL 2 ITEM NUMBER and DESCRIPTION	COL 3 ENGINEER'S ESTIMATE OF QUANTITY	COL 4 UNIT	COL 5 UNIT PRICE (IN FIGURES)	COL 6 TOTAL AMOUNT (IN FIGURES)
153	UTL-6.01.9 (CE) GAS MAIN CROSSING WATER MAIN UP TO 20" IN DIAMETER (\$6.01) Unit price bid shall not be less than: \$ 485.00	2.00	EACH	485.00	970.00
154	UTL-6.01.9 (NG) GAS MAIN CROSSING WATER MAIN UP TO 20" IN DIAMETER (\$6.01) Unit price bid shall not be less than: \$ 485.00	8.00	EACH	485.00	3880.00
155	UTL-6.02 (CE) EXTRA EXCAVATION FOR THE INSTALLATION OF CATCH BASIN SEWER DRAIN PIPES WITH GAS INTERFERENCES (\$6.02) Unit price bid shall not be less than: \$ 715.00	10.00	EACH	715.00	7150.00
156	UTL-6.02 (NG) EXTRA EXCAVATION FOR THE INSTALLATION OF CATCH BASIN SEWER DRAIN PIPES WITH GAS INTERFERENCES (\$6.02) Unit price bid shall not be less than: \$ 715.00	80.00	EACH	715.00	57,200.00
157	UTL-6.03 (CE) REMOVAL OF ABANDONED GAS FACILITIES. ALL SIZES. (\$6.03) Unit price bid shall not be less than: \$ 15.00	1,000.00	L.F.	15.00	15,000.00
158	UTL-6.03 (NG) REMOVAL OF ABANDONED GAS FACILITIES. ALL SIZES. (\$6.03) Unit price bid shall not be less than: \$ 15.00	2,000.00	L.F.	15.00	30,000.00



NEW YORK CITY DEPARTMENT OF DESIGN AND CONSTRUCTION
 DIVISION OF INFRASTRUCTURE - BUREAU OF DESIGN

PROJECT ID: SEQBN11
 CONTRACT PIN: 8502019SE0033C

10/3/2019 11:08 AM

REBID: N/A

BID SCHEDULE FORM

COL 1 SEQ. NO.	COL 2 ITEM NUMBER AND DESCRIPTION	COL 3 COAL ENGINEER'S ESTIMATE OF QUANTITY	COL 4 UNIT	COL 5 EST. PRICE PER UNIT	COL 6 TOTAL EST. PRICE
159	UTL-6.03.1 (NG) REMOVAL OF ABANDONED GAS FACILITIES WITH POSSIBLE COAL TAR WRAP. ALL SIZES. (FOR NATIONAL GRID WORK ONLY) (\$6.03) Unit price bid shall not be less than: \$ 25.00	300.00	L.F.	25.00	7500.00
160	UTL-6.03.1A (CE) REMOVAL OF ABANDONED GAS FACILITIES WITH POSSIBLE COAL TAR WRAP. ALL SIZES. (FOR CON EDISON WORK ONLY) (\$6.03) Unit price bid shall not be less than: \$ 25.00	100.00	L.F.	25.00	2500.00
161	UTL-6.04 (CE) ADJUST HARDWARE TO GRADE USING SPACER RINGS/ADAPTORS. (STREET REPAVING.) (\$6.04) Unit price bid shall not be less than: \$ 35.00	50.00	EACH	35.00	1750.00
162	UTL-6.04 (NG) ADJUST HARDWARE TO GRADE USING SPACER RINGS/ADAPTORS. (STREET REPAVING.) (\$6.04) Unit price bid shall not be less than: \$ 35.00	30.00	EACH	35.00	1050.00
163	UTL-6.05 (CE) ADJUST HARDWARE TO GRADE BY RESETTING. (ROAD RECONSTRUCTION.) (\$6.05) Unit price bid shall not be less than: \$ 65.00	50.00	EACH	65.00	3250.00
164	UTL-6.05 (NG) ADJUST HARDWARE TO GRADE BY RESETTING. (ROAD RECONSTRUCTION.) (\$6.05) Unit price bid shall not be less than: \$ 65.00	30.00	EACH	65.00	1950.00

10/3/2019 11:08 AM

REBID: N/A

BID SCHEDULE FORM

COL 1 SEQ. NO.	COL 2 ITEM NUMBER AND DESCRIPTION	COL 3 QUANTITY	COL 4 UNIT	COL 5 UNIT PRICE (FIGURES) DOLLARS CTS	COL 6 EXTENDED AMOUNT IN FIGURES DOLLARS CTS
165	UTL-6.06 (CE) SPECIAL CARE EXCAVATION AND BACKFILLING (\$6.06) Unit price bid shall not be less than: \$ 180.00	500.00	C.Y.	180 00	90,000 00
166	UTL-6.06 (NG) SPECIAL CARE EXCAVATION AND BACKFILLING (\$6.06) Unit price bid shall not be less than: \$ 180.00	1,300.00	C.Y.	180 00	234,000 00
167	UTL-6.06A (NG) SPECIAL CARE EXCAVATION AND BACKFILLING FOR TRANSMISSION MAINS (TRANSMISSION MAIN IS DESCRIBED AS ANY GAS MAIN WITH A MAOP GREATER THAN 124-PSIG) (\$6.06A) Unit price bid shall not be less than: \$ 230.00	50.00	C.Y.	230 00	11,500 00
168	UTL-6.07 (NG) TEST PITS FOR GAS FACILITIES (\$6.07) Unit price bid shall not be less than: \$ 100.00	100.00	C.Y.	100 00	10,000 00
169	UTL-6.09 (NG) TRENCH EXCAVATION AND BACKFILL FOR GAS MAINS AND SERVICES. GAS INSTALLED BY OTHERS (FOR NATIONAL GRID WORK ONLY), (\$6.09) Unit price bid shall not be less than: \$ 190.00	50.00	C.Y.	190 00	9,500 00



Department of
Design and
Construction

10/3/2019 11:08 AM

NEW YORK CITY DEPARTMENT OF DESIGN AND CONSTRUCTION
DIVISION OF INFRASTRUCTURE - BUREAU OF DESIGN

PROJECT ID: SEQBN11

CONTRACT PIN: 8502019SE0033C

REBID: N/A

BID SCHEDULE FORM

CO	LINE ITEM	QTY	C.Y.	UNIT PRICE	TOTAL PRICE
170	UTL-6.09A (CE) TRENCH EXCAVATION AND BACKFILL FOR GAS MAINS AND SERVICES. GAS INSTALLED BY OTHERS (FOR CON EDISON WORK ONLY). (\$6.09) Unit price bid shall not be less than: \$ 190.00	100.00		190.00	19,000.00
171	UTL-GCS-2WS (CE) GAS INTERFERENCES AND ACCOMMODATIONS PRICE BID SHALL BE FOR THE FIXED SUM OF \$ 30,000.00	1.00	F.S.	30,000.00	\$30,000.00
172	UTL-GCS-2WS (NG) GAS INTERFERENCES AND ACCOMMODATIONS PRICE BID SHALL BE FOR THE FIXED SUM OF \$ 50,000.00	1.00	F.S.	50,000.00	\$50,000.00

TOTAL BID PRICE: \$ 7,586,047.70

PLEASE BE SURE A LEGIBLE BID IS ENTERED FOR EACH ITEM.
THE BIDDER SHALL INSERT THE TOTAL BID PRICE IN
THE BID FORM IN THIS BID BOOKLET.



**Department of
Design and
Construction**

**DIVISION OF INFRASTRUCTURE
BUREAU OF DESIGN**

VOLUME 1 OF 3

PROJECT ID: SEQBN11

RECONSTRUCTION OF EXISTING SEWERS, NORTH QUEENS

**Together With All Work Incidental Thereto
BOROUGH OF QUEENS
CITY OF NEW YORK**

Contractor

Dated _____, 20____



**Department of
Design and
Construction**

**THE CITY OF NEW YORK
DEPARTMENT OF DESIGN AND
CONSTRUCTION
DIVISION OF INFRASTRUCTURE
30-30 THOMSON AVENUE
LONG ISLAND CITY, NY, 11101
TEL: 718.391.1000
WEB: www.nyc.gov/ddc**

TO BE FILLED IN BY THE BIDDER:

BIDDER'S NAME:

**BID SECURITY (CIRCLE ONE):
BID BOND / CERTIFIED CHECK**

**NUMBER OF ADDENDUMS RECEIVED
AND ATTACHED TO BID:
____ ADDENDUMS**

DDC CLIENT AGENCY:
**THE DEPARTMENT OF
ENVIRONMENTAL PROTECTION
PREPARED BY:
IN-HOUSE DESIGN
DATE PREPARED:
09/12/2019**

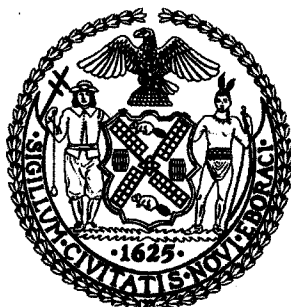

VOLUME 2 OF 3

FOR FURNISHING ALL LABOR AND MATERIALS
NECESSARY AND REQUIRED FOR:

PROJECT ID: SEQBN11

**INFORMATION FOR BIDDERS
CONTRACT**

**PERFORMANCE AND PAYMENT BONDS
PREVAILING WAGE SCHEDULE**

FOR FURNISHING ALL LABOR AND MATERIALS NECESSARY
AND REQUIRED FOR:

**RECONSTRUCTION OF EXISTING SEWERS,
NORTH QUEENS**

TOGETHER WITH ALL WORK INCIDENTAL THERETO
**BOROUGH OF QUEENS
CITY OF NEW YORK**

20-011





**Department of
Design and
Construction**

VOLUME 2 OF 3

**THE CITY OF NEW YORK
DEPARTMENT OF DESIGN AND
CONSTRUCTION
DIVISION OF INFRASTRUCTURE**
30-30 THOMSON AVENUE
LONG ISLAND CITY, NY, 11101
TEL: 718.391.1000
WEB: www.nyc.gov/ddc

**FOR FURNISHING ALL LABOR AND MATERIALS
NECESSARY AND REQUIRED FOR:
INFORMATION FOR BIDDERS
CONTRACT
PERFORMANCE AND PAYMENT BONDS
PREVAILING WAGE SCHEDULE**

TO BE FILLED IN BY THE BIDDER:

BIDDER'S NAME:

BID SECURITY (CIRCLE ONE):

BID BOND / CERTIFIED CHECK

**NUMBER OF ADDENDUMS RECEIVED
AND ATTACHED TO BID:**

____ ADDENDUMS

DDC CLIENT AGENCY:

**THE DEPARTMENT OF
ENVIRONMENTAL PROTECTION**

PREPARED BY:

IN-HOUSE DESIGN

DATE PREPARED:

March 1, 2017

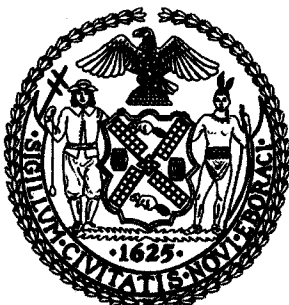



NOTICE TO BIDDERS

Please note that the Information for Bidders has been updated to include new Section 41, Viewing of Submitted Bid Documents.

(NO FURTHER TEXT ON THIS PAGE)

7/12/2019

DISCONTINUE THE USE OF THIS NOTICE ON 1/1/2020

(NO TEXT ON THIS PAGE)

**7/12/2019
DISCONTINUE THE USE OF THIS NOTICE ON 1/1/2020**

CITY OF NEW YORK

**DEPARTMENT OF
DESIGN AND CONSTRUCTION
DIVISION OF INFRASTRUCTURE**

INFORMATION FOR BIDDERS

JULY 2019

(NO TEXT ON THIS PAGE)

*CITY OF NEW YORK CITY
DEPARTMENT OF DESIGN AND CONSTRUCTION
INFORMATION FOR BIDDERS*

TABLE OF CONTENTS

SECTION 1.	DESCRIPTION AND LOCATION OF WORK	1
SECTION 2.	TIME AND PLACE FOR RECEIPT OF BIDS	1
SECTION 3.	DEFINITIONS	1
SECTION 4.	INVITATION FOR BIDS AND CONTRACT DOCUMENTS	1
SECTION 5.	PRE-BID CONFERENCE	2
SECTION 6.	AGENCY CONTACT	2
SECTION 7.	BIDDER'S OATH	2
SECTION 8.	EXAMINATION AND VIEWING OF SITE, CONSIDERATION OF OTHER SOURCES OF INFORMATION AND CHANGED CONDITIONS	2
SECTION 9.	EXAMINATION OF PROPOSED CONTRACT	3
SECTION 10.	FORM OF BID	3
SECTION 11.	IRREVOCABILITY OF BID	3
SECTION 12.	ACKNOWLEDGMENT OF AMENDMENTS	4
SECTION 13.	BID SAMPLES AND DESCRIPTIVE LITERATURE	4
SECTION 14.	PROPRIETARY INFORMATION/TRADE SECRETS	4
SECTION 15.	PRE-OPENING MODIFICATION OR WITHDRAWAL OF BIDS	4
SECTION 16.	BID EVALUATION AND AWARD	4
SECTION 17.	LATE BIDS, LATE WITHDRAWALS AND LATE MODIFICATIONS	5
SECTION 18.	WITHDRAWAL OF BIDS.	5
SECTION 19.	MISTAKE IN BIDS	5
SECTION 20.	LOW TIE BIDS	6
SECTION 21.	REJECTION OF BIDS	6
SECTION 22.	RIGHT TO APPEAL DETERMINATIONS OF NON-RESPONSIVENESS OR NON-RESPONSIBILITY AND RIGHT TO PROTEST SOLICITATIONS AND AWARD	7
SECTION 23.	AFFIRMATIVE ACTION AND EQUAL EMPLOYMENT OPPORTUNITY	7
SECTION 24.	PASSPORT COMPLIANCE	7
SECTION 25.	COMPLAINTS ABOUT THE BID PROCESS	8
SECTION 26.	BID, PERFORMANCE AND PAYMENT SECURITY	8
SECTION 27.	FAILURE TO EXECUTE CONTRACT	9
SECTION 28.	BIDDER RESPONSIBILITIES AND QUALIFICATIONS	9
SECTION 29.	EMPLOYMENT REPORT	10
SECTION 30.	LABOR LAW REQUIREMENTS	10
SECTION 31.	INSURANCE	10
SECTION 32.	LUMP SUM CONTRACTS	11
SECTION 33.	UNIT PRICE CONTRACTS	11
SECTION 34.	EXCISE TAX	11
SECTION 35.	LICENSES AND PERMITS	11
SECTION 36.	MULTIPLE PRIME CONTRACTORS	11
SECTION 37.	LOCALLY BASED ENTERPRISE REQUIREMENTS (LBE)	12
SECTION 38.	BID SUBMISSION REQUIREMENTS	13
SECTION 39.	COMPTROLLER'S CERTIFICATE	14
SECTION 40.	PROCUREMENT POLICY BOARD RULES	14
SECTION 41.	VIEWING OF SUBMITTED BID DOCUMENTS	14
SECTION 42.	DDC SAFETY REQUIREMENTS	14

(NO TEXT ON THIS PAGE)

INFORMATION FOR BIDDERS

1. Description and Location of Work

The description and location of the work for which bids are requested are specified in Attachment 1, "Bid Information". Attachment 1 is included in the BID BOOKLET, VOLUME 1 OF 3.

2. Time and Place for Receipt of Bids

Sealed bids shall be received on or before the date and hour specified in Attachment 1, at which time they will be publicly opened and read aloud in the presence of the Commissioner or his or her representative, and any bidders who may desire to be present.

3. Definitions

The definitions set forth in the Procurement Policy Board Rules shall apply to this Invitation For Bids.

4. Invitation For Bids and Contract Documents

(A) Except for titles, sub-titles, headings, running headlines, tables of contents and indices (all of which are printed herein merely for convenience) the following, except for such portions thereof as may be specifically excluded, shall be deemed to be part of the Contract and the Invitation for Bids.

- (1) All provisions required by law to be inserted in this Contract, whether actually inserted or not
- (2) The Contract Drawings and Specifications
- (3) The General Conditions, the General Requirements and the Special Conditions, if any
- (4) The Contract
- (5) The Information for Bidders; Request for Proposals; Notice of Solicitation and Proposal For Bids; Bid or Proposal, and, if used, the Bid Booklet
- (6) The Budget Director's Certificate; all Addenda issued prior to the receipt of the bids; the Notice of Award; Performance and Payment Bonds, if required; and the Notice to Proceed with the Work.

(B) For particulars as to this procurement, including quantity and quality of the purchase, extent of the work or labor to be performed, delivery and performance schedule, and any other special instructions, prospective bidders are referred to the Invitation For Bids Documents. A copy of such documents can be obtained at the location set forth in Attachment 1.

(C) Deposit for Copy of Invitation For Bids Documents: Prospective bidders may obtain a copy of the Invitation For Bids Documents by complying with the conditions set forth in the Notice of Solicitation. The deposit must be in the form of a check or money order made payable to the City of New York, and drawn upon a state or national bank or trust company, or a check of such bank or trust company signed by a duly authorized officer thereof.

(D) Return of Invitation For Bids Documents: All Invitation For Bids Documents must be returned to the Department upon request. If the bidder elects not to submit a bid thereunder, the

Invitation For Bids Documents shall be returned to the Department, along with a statement that no bid will be submitted.

(E) Return of Deposit: Such deposit will be returned within 30 days after the award of the contract or the rejection of all bids as set forth in the advertisement, provided the Invitation For Bids Documents are returned to the location specified in Attachment 1, in physical condition satisfactory to the Commissioner.

(F) Additional Copies: Additional copies of the Invitation For Bids Documents may be obtained, subject to the conditions set forth in the advertisement for bids.

5. Pre-Bid Conference

A pre-bid conference shall be held as set forth in Attachment 1. Nothing stated at the pre-bid conference shall change the terms or conditions of the Invitation For Bids Documents, unless a change is made by written amendment as provided in Section 9 below. Failure to attend a mandatory pre-bid conference shall constitute grounds for the rejection of the bid.

6. Agency Contact

Any questions or correspondence relating to this bid solicitation shall be addressed to the Agency Contact person specified in Attachment 1.

7. Bidder's Oath

(A) The bid shall be properly signed by an authorized representative of the bidder and the bid shall be verified by the written oath of the authorized representative who signed the bid, that the several matters stated and information furnished therein are in all aspects true.

(B) A materially false statement willfully or fraudulently made in connection with the bid or any of the forms completed and submitted with the bid may result in the termination of any Contract between the City and the Bidder. As a result, the Bidder may be barred from participating in future City contracts as well as be subject to possible criminal prosecution.

8. Examination and Viewing of Site

(A) Pre-Bidding (Investigation) Viewing of Site -Bidders must carefully view and examine the site of the proposed work, as well as its adjacent area, and seek other usual sources of information, for they will be conclusively presumed to have full knowledge of any and all conditions on, about or above the site relating to or affecting in any way the performance of the work to be done under the Contract which were or should have been indicated to a reasonably prudent bidder. To arrange a date for visiting the work site, bidders are to contact the Agency Contact person specified in Attachment 1.

(B) Should the contractor encounter during the progress of the work subsurface conditions at the site materially differing from any shown on the Contract Drawings or indicated in the Specifications or such subsurface conditions as could not reasonably have been anticipated by the contractor and were not anticipated by the City, which conditions will materially affect the cost of the work to be done under the

Contract, the attention of the Commissioner must be called immediately to such conditions before they are disturbed. The Commissioner shall thereupon promptly investigate the conditions. If he finds that they do so materially differ, or that they could not have been reasonably anticipated by the contractor and were not anticipated by the City, the Contract may be modified with his written approval.

9. Examination of Proposed Contract

(A) Request for Interpretation or Correction: Prospective bidders must examine the Contract Documents carefully and before bidding must request the Commissioner in writing for an interpretation or correction of every patent ambiguity, inconsistency or error therein which should have been discovered by a reasonably prudent bidder. Such interpretation or correction, as well as any additional contract provisions the Commissioner may decide to include, will be issued in writing by the Commissioner as an addendum to the Contract, which will be transmitted to each person recorded as having received a copy of the Contract Documents from the Department. Transmission of such addendum will be by mail, e-mail, facsimile or hand delivery. Such addendum will also be posted at the place where the Contract Documents are available for the inspection of prospective bidders. Upon transmission as provided for herein, such addendum shall become a part of the Contract Documents, and binding on all bidders, whether or not actual notice of such addendum is shown.

(B) Only Commissioner's Interpretation or Correction Binding: Only the written interpretation or correction so given by the Commissioner shall be binding, and prospective bidders are warned that no other officer, agent or employee of the City is authorized to give information concerning, or to explain or interpret, the Contract.

(C) Documents given to a subcontractor for the purpose of soliciting the subcontractor's bid shall include either a copy of the bid cover sheet or a separate information sheet setting forth the project name, the Contract number (if available), the contracting agency and the Project's location.

10. Form of Bid

Each bid must be submitted upon the prescribed form and must contain: a) the name, residence and place of business of the person or persons making the same; b) the names of all persons interested therein, and if no other person is so interested, such fact must be distinctly stated; c) a statement to the effect that it is made without any connection with any other person making a bid for the same purpose and that it is in all respects fair and without collusion or fraud; d) a statement that no Council member or other officer or employee or person whose salary is payable in whole or part from the City Treasury is directly or indirectly interested therein or in the supplies, materials or equipment and work or labor to which it relates, or in any portion of the profits thereof; e) a statement that the bidder is not in arrears to the City or to any agency upon a debt or contract or taxes, and is not a defaulter as surety or otherwise upon any obligation to the City to any agency thereof, except as set forth in the bid.

THE BID SHALL BE TYPEWRITTEN OR WRITTEN LEGIBLY IN INK. THE BID SHALL BE SIGNED IN INK. ERASURES OR ALTERATIONS SHALL BE INITIALED BY THE SIGNER IN INK. FAILURE TO CONFORM TO THE REQUIREMENTS OF THIS SECTION 10 SHALL RESULT IN THE REJECTION OF THE BID.

11. Irrevocability of Bid

The prices set forth in the bid cannot be revoked and shall be effective until the award of the Contract, unless the bid is withdrawn as provided for in Sections 15 and 18 below.

12. Acknowledgment of Amendments

The receipt of any amendment to the Contract Documents shall be acknowledged by the bidder in its bid submission.

13. Bid Samples and Descriptive Literature

Bid samples and descriptive literature shall not be submitted by the bidder, unless expressly requested elsewhere in the Contract or Contract Documents. Any unsolicited bid samples or descriptive literature which are submitted shall not be examined or tested and shall not be deemed to vary any of the provisions of this Contract.

14. Proprietary Information/Trade Secrets

(A) The bidder shall identify those portions of the bid which it deems to be confidential, proprietary information or trade secrets, and provide justification why such materials shall not be disclosed by the City. All such materials shall be clearly indicated by stamping the pages on which such information appears, at the top and bottom thereof with the word "Confidential". Such materials stamped "Confidential" must be easily separable from the non-confidential sections of the bid.

(B) All such materials so indicated shall be reviewed by the Agency and any decision not to honor a request for confidentiality shall be communicated in writing to the bidder. For those bids which are unsuccessful, all such confidential materials shall be returned to the bidder. Prices, makes and model or catalog numbers of the items offered, deliveries, and terms of payment shall be publicly available after bid opening, regardless of any designation of confidentiality made by the bidder.

15. Pre-Opening Modification or Withdrawal of Bids

Bids may be modified or withdrawn by written notice received in the office designated in Attachment 1, before the time and date set for the bid opening. If a bid is withdrawn in accordance with this Section, the bid security, if any, shall be returned to the bidder.

16. Bid Evaluation and Award

In accordance with the New York City Charter, the Procurement Policy Board Rules and the terms and conditions of this Invitation For Bids, this Contract shall be awarded, if at all, to the responsible bidder whose bid meets the requirements and evaluation criteria set forth in the Invitation For Bids, and whose bid price is either the most favorable bid price or, if the Invitation For Bids so states, the most favorable evaluated bid price. A bid may not be evaluated for any requirement or criterion that is not disclosed in the Invitation For Bids.

Restriction: No negotiations with any bidder shall be allowed to take place except under the circumstances and in the manner set forth in Section 21. Nothing in this Section shall be deemed to permit a contract award to a bidder submitting a higher quality item than that designated in the Invitation For Bids, if that bid is not also the most favorable bid.

17. Late Bids, Late Withdrawals and Late Modifications

Any bid received at the place designated in the solicitation after the time and date set for receipt of bids is late and shall not be considered. Any request for withdrawal or modification received at the place designated in the solicitation after the time and date set for receipt of bids is late and shall not be considered. The exception to this provision is that a late modification of a successful bid that makes the bid terms more favorable to the City shall be considered at any time it is received.

18. Withdrawal of Bids.

Except as provided for in Section 15, above, a bidder may not withdraw its bid before the expiration of forty-five (45) days after the date of the opening of bids; thereafter, a bidder may withdraw its bid only in writing and in advance of an actual award. If within sixty (60) days after the execution of the Contract, the Commissioner fails to fix the date for commencement of work by written notice to the bidder, the bidder, at his option, may ask to be relieved of his obligation to perform the work called for by written notice to the Commissioner. If such notice is given to the Commissioner, and the request to withdraw is granted, the bidder waives all claims in connection with this Contract.

19. Mistake in Bids

(A) Mistake Discovered Before Bid Opening: A bidder may correct mistakes discovered before the time and date set for bid opening by withdrawing or correcting the bid as provided in Section 15 above.

(B) Mistakes Discovered Before Award

(1) In accordance with General Municipal Law (Section 103, subdivision 11), where a unilateral error or mistake is discovered in a bid, such bid may be withdrawn upon written approval of the Agency Chief Contracting Officer if the following conditions are met:

- (a) The mistake is known or made known to the agency prior to the awarding of the Contract or within 3 days after the opening of the bid, whichever period is shorter; and
- (b) The price bid was based upon an error of such magnitude that enforcement would be unconscionable; and
- (c) The bid was submitted in good faith and the bidder submits credible evidence that the mistake was a clerical error as opposed to a judgment error; and
- (d) The error in the bid is actually due to an unintentional and substantial arithmetic error or an unintentional omission of a substantial quantity of work, labor, material or services made directly in the compilation of the bid, which unintentional arithmetic error or unintentional omission can be clearly shown by objective evidence drawn from inspection of the original work paper, documents, or materials used in the preparation of the bid sought to be withdrawn; and
- (e) It is possible to place the agency in the same position as existed prior to the bid.

(2) Unless otherwise required by law, the sole remedy for a bid mistake in accordance with this Article shall be withdrawal of the bid, and the return of the bid bond, or other security, if any, to the bidder. Thereafter, the agency may, in its discretion, award the Contract to the next lowest bidder or rebid the Contract. Any amendment to or reformation of a bid or a Contract to rectify such an error or mistake

therein is strictly prohibited.

(3) If the mistake and the intended correct bid are clearly evident on the face of the bid document, the bid shall be corrected to the intended correct bid and may not be withdrawn. Examples of mistakes that may be corrected are typographical errors, errors in extending unit prices, transposition errors and arithmetical errors.

20. Low Tie Bids

(A) When two or more low responsive bids from responsible bidders are identical in price, meeting all the requirements and criteria set forth in the Invitation For Bids, the Agency Chief Contracting Officer will break the tie in the following manner and order of priority:

- (1) Award to a certified New York City small, minority or woman-owned business entity bidder;
- (2) Award to a New York City bidder;
- (3) Award to a certified New York State small, minority or woman-owned business bidder;
- (4) Award to a New York State bidder.

(B) If two or more bidders still remain equally eligible after application of paragraph (A) above, award shall be made by a drawing by lot limited to those bidders. The bidders involved shall be invited to attend the drawing. A witness shall be present to verify the drawing and shall certify the results on the bid tabulation sheet.

21. Rejection of Bids

(A) Rejection of Individual Bids: The Agency may reject a bid if:

- (1) The bidder fails to furnish any of the information required pursuant to Section 24 or 28 hereof; or if
- (2) The bidder is determined to be not responsible pursuant to the Procurement Policy Board Rules; or if
- (3) The bid is determined to be non-responsive pursuant to the Procurement Policy Board Rules; or if
- (4) The bid, in the opinion of the Agency Chief Contracting Officer, contains unbalanced bid prices and is thus non-responsive, unless the bidder can show that the prices are not unbalanced for the probable required quantity of items, or if the imbalance is corrected pursuant to Section 15.

(B) Rejection of All Bids: The Agency, upon written approval by the Agency Chief Contracting Officer, may reject all bids and may elect to resolicit bids if in its sole opinion it shall deem it in the best interest of the City so to do.

(C) Rejection of All Bids and Negotiation With All Responsible Bidders: The Agency Head may determine that it is appropriate to cancel the Invitation For Bids after bid opening and before award and to complete the acquisition by negotiation. This determination shall be based on one of the following reasons:

- (1) All otherwise acceptable bids received are at unreasonable prices, or only one bid is received and the Agency Chief Contracting Officer cannot determine the reasonableness of the bid price, or no responsive bid has been received from a responsible bidder; or
- (2) In the judgment of the Agency Chief Contracting Officer, the bids were not independently arrived at in open competition, were collusive, or were submitted in bad faith.

(D) When the Agency has determined that the Invitation for Bids is to be canceled and that use of negotiation is appropriate to complete the acquisition, the contracting officer may negotiate and award the Contract without issuing a new solicitation, subject to the following conditions:

- (1) prior notice of the intention to negotiate and a reasonable opportunity to negotiate have been given by the contracting officer to each responsible bidder that submitted a bid in response to the Invitation for Bids;
- (2) the negotiated price is the lowest negotiated price offered by a responsible bidder; and
- (3) the negotiated price is lower than the lowest rejected bid price of a responsible bidder that submitted a bid in response to the Invitation for Bids.

22. Right to Appeal Determinations of Non-Responsiveness or Non-Responsibility and Right to Protest Solicitations and Award

The bidder has the right to appeal a determination of non-responsiveness or non-responsibility and has the right to protest a solicitation and award. For further information concerning these rights, the bidder is directed to the Procurement Policy Board Rules.

23. Affirmative Action and Equal Employment Opportunity

This Invitation For Bids is subject to applicable provisions of Federal, State and Local Laws and executive orders requiring affirmative action and equal employment opportunity.

24. PASSPort COMPLIANCE

All vendors that intend to do business with the City of New York must complete a disclosure process in order to be considered for a contract. This disclosure process was formerly completed using Vendor Information Exchange System (VENDEX) paper-based forms. The City of New York has moved collection of vendor disclosure information online. In early August 2017, the New York City Mayor's Office of Contract Services (MOCS) launched the Procurement and Sourcing Solutions Portal (PASSPort), a new online procurement system that replaced the paper-VENDEX process. In anticipation of awards, all bidders must create online accounts in the new PASSPort system, and file all disclosure information using PASSPort. Paper submissions, including certifications of no changes to existing VENDEX packages, will not be accepted in lieu of complete online filings using PASSPort.

All vendors that intend to do business with the City, but specifically those that fall into any of the following categories, are required to enroll:

- Have a pending award with a City Agency; or
- Hold a current contract with a City Agency and have either an expiring VENDEX or expiring Certificate of No Change.

The Department of Design and Construction (DDC) and MOCS hereby notifies all proposers that the PASSPort system is available, and that disclosure filing completion is required prior to any award through this competitive bid.

To enroll in PASSPort and to access the PASSPort website (including online training), please visit www.nyc.gov/passport. Contact MOCS at passport@mocs.nyc.gov for additional information and technical support.

25. Complaints About the Bid Process

The New York City Comptroller is charged with the audit of contracts in New York City. Any vendor who believes that there has been unfairness, favoritism or impropriety in the bid process should inform the Comptroller, Office of Contract Administration, One Centre Street, Room 835, New York, New York; telephone number (212) 669-2323.

26. Bid, Performance and Payment Security

(A) Bid Security: Each bid must be accompanied by bid security in an amount and type specified in Attachment 1 (BID BOOKLET, VOLUME 1 OF 3). The bid security shall assure the City of New York of the adherence of the bidder to its proposal, the execution of the Contract, and the furnishing of Performance and Payment Bonds by the bidder, if required in Attachment 1. Bid security shall be returned to the bidder as follows:

- (1) Within ten (10) days after the bid opening, the Comptroller will be notified to return the deposits of all but the three (3) lowest bidders. Within five (5) days after the award, the Comptroller will be notified to return the deposits of the remaining two unsuccessful bidders.
- (2) Within five (5) days after the execution of the Contract and acceptance of the Contractor's bonds, the Comptroller will be notified to return the bid security of the successful bidder or, if performance and payment bonds are not required, only after the sum retained under Article 21 of the Contract equals the amount of the bid security.
- (3) Where all bids are rejected, the Comptroller will be notified to return the deposit of the three (3) lowest bidders at the time of rejection.

(B) Performance and Payment Security: Performance and Payment Security must be provided in an amount and type specified in Attachment 1 (BID BOOKLET, VOLUME 1 OF 3). The performance and payment security shall be delivered by the contractor prior to or at the time of execution of the Contract. If a contractor fails to deliver the required performance and payment security, its bid security shall be enforced, and an award of Contract may be made to the next lowest responsible and responsive bidder, or the contract may be rebid.

(C) Acceptable Types of Security: Acceptable types of security for bids, performance, and payment shall be limited to the following:

- (1) a one-time bond in a form satisfactory to the City;
- (2) a bank certified check or money order;
- (3) obligations of the City of New York; or
- (4) other financial instruments as determined by the Office of Construction in consultation with the Comptroller.

Whenever the successful bidder deposits obligations of the City of New York as performance and payment security, the Comptroller may sell and use the proceeds thereof for any purpose for which the principal or surety on such bond would be liable under the terms of the Contract. If the money is deposited with the Comptroller, the successful bidder shall not be entitled to receive interest on such money from the City.

(D) Form of Bonds: Security provided in the form of bonds must be prepared on the form of bonds authorized by the City of New York. Forms for bid, performance, and payment bonds are included in the Invitation for Bids Documents. Such bonds must have as surety thereunder such surety company or companies as are: (1) approved by the City of New York; (2) authorized to do business in the State of New York, and (3) approved by the Department of the Treasury of the United States. Premiums for any required bonds must be included in the base bid.

The bidder is advised that submission of a bid bond where the surety on such bond fails to meet the criteria set forth herein, shall result in the rejection of the bid as non-responsive.

The Department of the Treasury of the United States advises that information concerning approved surety companies may be obtained as follows: (1) from the Government Printing Office at 215-364-6465; (2) through the Internet at <https://www.fiscal.treasury.gov/surety-bonds/>.

(E) Power of Attorney: Attorneys in fact who sign bid, performance, or payment bonds must file with each bond a certified copy of their power of attorney to sign said bonds.

27. Failure to Execute Contract

In the event of failure of the successful bidder to execute the Contract and furnish the required security within ten (10) days after notice of the award of the Contract, the deposit of the successful bidder or so much thereof as shall be applicable to the amount of the award made shall be retained by the City, and the successful bidder shall be liable for and hereby agrees to pay on demand the difference between the price bid and the price for which such Contract shall be subsequently awarded, including the cost of any required reletting and less the amount of such deposit. No plea of mistake in such accepted bid shall be available to the bidder for the recovery of the deposit or as a defense to any action based upon such accepted bid. Further, should the bidder's failure to comply with this Section cause any funding agency, body or group (Federal, State, City, Public, Private, etc.) to terminate, cancel or reduce the funding on this project, the bidder in such event shall be liable also to the City for the amount of actual funding withdrawn by such agency on this project, less the amount of the forfeited deposit.

28. Bidder Responsibilities and Qualifications

(A) Bidders must include with their bids all information necessary for a determination of bidder responsibility, as set forth in the Specifications.

(B) The Agency may require any bidder or prospective bidder to furnish all books of account, records, vouchers, statements or other information concerning the bidder's financial status for examination as may be required by the Agency to ascertain the bidder's responsibility and capability to perform the Contract. If required, a bidder must also submit a sworn statement setting forth such information as the Agency may require concerning present and proposed plant and equipment, the personnel and qualifications of his working organizations, prior experience and performance record.

(C) Oral Examination on Qualifications: In addition thereto, and when directed by the Agency, the bidder, or a responsible officer, agent or employee of the bidder, must submit to an oral examination to be conducted by the Agency in relation to his proposed tentative plan and schedule of

operations, and such other matters as the Agency may deem necessary in order to determine the bidder's ability and responsibility to perform the work in accordance with the Contract. Each person so examined must sign and verify a stenographic transcript of such examination noting thereon such corrections as such person may desire to make.

(D) If the bidder fails or refuses to supply any of the documents or information set forth in paragraph (B) hereof or fails to comply with any of the requirements thereof, the Agency may reject the bid.

29. Employment Report

In accordance with Executive Order No. 50 (1980) as modified by Executive Order 108 (1986), the filing of a completed Employment Report (ER) is a requirement of doing business with the City of New York for construction contractors with contracts of \$1,000,000 or more and subcontractors with construction subcontracts of \$750,000 or more. The required forms and information are included in the Bid Booklet.

30. Labor Law Requirements

(A) General: The successful bidder will be required to comply strictly with all Federal, State and local labor laws and regulations.

(B) New York State Labor Law: This Contract is subject to New York State Labor Law Section 220, which requires that construction workers on the site be paid prevailing wages and supplements. The Contractor is reminded that all wage provisions of this Contract will be enforced strictly and failure to comply will be considered when evaluating performance. Noncompliance may result in the contractor being debarred by the City from future contracts. Complaints filed with the Comptroller may result in decisions which may debar a contractor from bidding contracts with any state governmental entity and other political subdivisions.

(C) Records: The Contractor is expected to submit accurate payroll reports and other required documents and verify attendance and job classifications being utilized in compliance with the law, Contract provisions and agency procedures.

31. Insurance

(A) Bidders are advised that the insurance requirements contained herein are regarded as material terms of the Contract. As required by Article 22 of the Contract, the contractor must effect and maintain with companies licensed and authorized to do business in the State of New York, the types of insurance set forth therein, when required by and in the amounts set forth in Schedule A of the General Conditions. Such required insurance must be provided from the date the contractor is ordered to commence work and up to the date of final acceptance of all required work.

(B) The contractor must, within ten days of receipt of the notice of award, submit the following insurance documentation: (a) original certificate of insurance for general liability in the amount required by Schedule A of the General Conditions, and (b) original certificates of insurance or other proof of coverage for workers' compensation and disability benefits, as required by Section 57 of the New York State Workers' Compensation Law and Section 220 of the Disability Benefits Law.

32. Lump Sum Contracts

(A) Comparison of Bids: Bids on Lump Sum Contracts will be compared on the basis of the lump sum price bid, adjusted for alternate prices bid, if any.

(B) Lump Sum Bids for "General Construction Work" which include excavation shall include all necessary excavation work defined in the Specifications as being included in the lump sum bid. The bidder shall also bid a unit price for the additional cost of excavating material which is defined in the Specifications as excavation for which additional payment will be made. The total estimated additional cost of removing such material will be taken as the quantity set forth in the Engineer's Estimate multiplied by the unit price bid. This total estimated cost of additional excavation shall be added to the lump sum bid for the General Construction Work for the purpose of comparing bids to determine the low bidder.

(C) Variations from Engineer's Estimate: The Engineer's Estimate of the quantity of excavation for which additional payment will be made is approximate only and is given solely to be used as a uniform basis for the comparison of bids and such estimate is not to be considered as part of this contract. The quantities actually required to complete the contract work may be more or less than the quantities in the Engineer's Estimate and, if so, no action for damages or for loss of profits shall accrue to the contractor by reason thereof.

33. Unit Price Contracts

(A) Comparison of Bids: Bids on Unit Price Contracts will be compared on the basis of a total estimated price, arrived at by taking the sum of the estimated quantities of such items, in accordance with the Engineer's Estimate of Quantities set forth in the Bid Schedule, multiplied by the corresponding unit prices, and including any lump sum bids on individual items.

(B) Variations from Engineer's Estimate: Bidders are warned that the Engineer's Estimate of Quantities on the various items of work and materials is approximate only, given solely to be used as a uniform basis for the comparison of bids, and is not to be considered part of this contract. The quantities actually required to complete the contract work may be less or more than so estimated, and if so, no action for damages or for loss of profits shall accrue to the contractor by reason thereof.

(C) Overruns: The terms and conditions applicable to overruns of unit price items are set forth in Article 26 of the Contract.

34. Excise Tax

Bidders are referred to the Specifications for information on Federal Excise Tax exemptions.

35. Licenses and Permits

The successful bidder will be required to obtain all necessary licenses and permits necessary to perform the work.

36. Multiple Prime Contractors

If more than one prime contractor will be involved on this project, all contractors are required to examine the Invitation for Bid packages for all other parts of the project.

37. Locally Based Enterprise Requirements (LBE)

This Contract is subject to the requirements of Administrative Code, Section 6-108.1, and the regulations promulgated thereunder. No construction contract will be awarded unless and until these requirements have been complied with in their entirety. The bidder is advised of the provisions set forth below, as well as the provisions with respect to the Locally Based Enterprise Program contained in Article 67 of the Contract. The contractor is advised that:

(A) If any portion of the Contract is subcontracted, not less than ten percent of the total dollar amount of the contract shall be awarded to locally based enterprises ("LBEs"); except, where less than ten percent of the total dollar amount of the Contract is subcontracted, such lesser percentage shall be so awarded.

(B) No contractor shall require performance and payment bonds from LBE subcontractors.

(C) No Contract shall be awarded unless the contractor first identifies in its bid:

- (1) the percentage, dollar amount and type of work to be subcontracted; and
- (2) the percentage, dollar amount and type of work to be subcontracted to LBEs.

(D) Within ten calendar days after notification of low bid, the apparent low bidder shall submit an "LBE Participation Schedule" to the contracting agency. If such schedule does not identify sufficient LBE subcontractors to meet the requirements of Administrative Code Section 6-108.1, the apparent low bidder shall submit documentation of its good faith efforts to meet such requirements.

(1) The "LBE Participation Schedule" shall include:

- (a) the name and address of each LBE that will be given a subcontract,
- (b) the percentage, dollar amount and type of work to be subcontracted to the LBE, and
- (c) the dates when the LBE subcontract work will commence and end.

(2) The following documents shall be attached to the "LBE Participation Schedule":

- (a) verification letters from each subcontractor listed in the "LBE Participation Schedule" stating that the LBE will enter into a formal agreement for work,
- (b) certification documents of any proposed LBE subcontractor which is not on the LBE certified list, and
- (c) copies of the certification letter of any proposed subcontractor which is an LBE.

(3) Documentation of good faith efforts to achieve the required LBE percentage shall include as appropriate but not limited to the following:

- (a) attendance at prebid meetings, when scheduled by the agency, to advise bidders of contract requirements;

- (b) advertisement where appropriate in general circulation media, trade association publications and small business media of the specific subcontracts that would be at least equal to the percentage goal for LBE utilization specified by the contractor;
- (c) written notification to association of small, minority and women contractors soliciting specific subcontractors;
- (d) written notification by certified mail to LBE firms that their interest in the contract is solicited for specific work items and their estimated values;
- (e) demonstration of efforts made to select portions of the work for performance by LBE firms in order to increase the likelihood of achieving the stated goal;
- (f) documented efforts to negotiate with LBE firms for specific subcontracts, including at a minimum:
 - (i) The names, address and telephone numbers of LBE firms that are contacted;
 - (ii) A description of the information provided to LBE firms regarding the plans and specifications for portions of the work to be performed;
 - (iii) Documentation showing that no reasonable price can be obtained from LBE firms;
 - (iv) A statement of why agreements with LBE firms were not reached;
- (g) a statement of the reason for rejecting any LBE firm which the contractor deemed to be unqualified; and
- (h) documentation of efforts made to assist the LBE firms contacted that needed assistance in obtaining required insurance.

(E) Unless otherwise waived by the Commissioner with the approval of the Office of Economic and Financial Opportunity, failure of a proposed contractor to provide the information required by paragraphs (C) and (D) above may render the bid non-responsive and the Contract may not be awarded to the bidder. If the contractor states that it will subcontract a specific portion of the work, but can demonstrate despite good faith efforts it cannot achieve its required LBE percentage for subcontracted work until after award of Contract, the Contract may be awarded, subject to a letter of compliance from the contractor stating that it will comply with Administrative Code Section 6-108.1 and subject to approval by the Commissioner. If the contractor has not met its required LBE percentage prior to award, the contractor shall demonstrate that a good faith effort has been made subsequent to award to obtain LBEs on each subcontract until it meets the required percentage.

(F) When a bidder indicates prior to award that no work will be subcontracted, no work may be subcontracted without the prior written approval of the Commissioner, which shall be granted only if the contractor in good faith seeks LBE subcontractors at least six weeks prior to the start of work.

(G) The contractor may not substitute or change any LBE which was identified prior to award of the contract without the written permission of the Commissioner. The contractor shall make a written application to the Commissioner for permission to make such substitution or change, explaining why the contractor needs to change its LBE subcontractor and how the contractor will meet its LBE subcontracting requirement. Copies of such application must be served on the originally identified LBE by certified mail return receipt requested, as well as the proposed substitute LBE. The Commissioner shall determine whether or not to grant the contractor's request for substitution.

38. Bid Submission Requirements

The Bid Submission Requirements are set forth in the BID BOOKLET VOLUME 1 OF 3.

39. Comptroller's Certificate

This Contract shall not be binding or of any force unless it is registered by the Comptroller in accordance with Section 328 of the City Charter and the Procurement Policy Board Rules. This Contract shall continue in force only after annual appropriation of funds by the City of New York and certification as hereinabove set forth.

40. Procurement Policy Board Rules

This Invitation For Bids is subject to the Rules of the Procurement Policy Board of the City of New York. In the event of a conflict between said Rules and a provision of this Invitation For Bids, the Rules shall take precedence.

41. Viewing of Submitted Bid Documents

In accordance with Procurement Policy Board Rules of the City of New York, Section 3-02, the submitted bid documents will be available to view immediately after completion of the bid opening and by appointment for up to 72 hours after the bid opening.

42. DDC Safety Requirements

The DDC Safety Requirements apply to the work to be performed pursuant to the Contract. The DDC Safety Requirements are set forth on the following pages.

CITY OF NEW YORK
DEPARTMENT OF DESIGN AND CONSTRUCTION
SAFETY REQUIREMENTS

FEBRUARY 2019

THE DDC SAFETY REQUIREMENTS INCLUDE THE FOLLOWING SECTIONS:

- I. POLICY ON SITE SAFETY
- II. PURPOSE
- III. DEFINITIONS
- IV. RESPONSIBILITIES
- V. SAFETY QUESTIONNAIRE
- VI. SAFETY PROGRAM AND SITE SAFETY PLAN
- VII. KICK-OFF/PRE-CONSTRUCTION MEETINGS AND SAFETY REVIEW
- VIII. EVALUATION DURING WORK IN PROGRESS
- IX. SAFETY PERFORMANCE EVALUATION

City of New York Department of Design and Construction: Safety Requirements
Safety and Site Support– Quality Assurance and Construction Safety

I. POLICY ON SITE SAFETY

The City of New York Department of Design and Construction (DDC) is committed to a policy of injury and illness prevention and risk management for construction work that will ensure the safety and health of the workers engaged in the projects and the protection of the general public. Therefore, it is DDC's policy that work carried out by Contractors on DDC jobsites must, at a minimum, comply with applicable federal, state and city laws, rules and regulations, including without limitation:

- U. S. Department of Labor 29 Code of Federal Regulations (CFR) Part 1926 and applicable Sub-parts of Part 1910 – U.S. Occupational Safety and Health Administration (OSHA); New York State Department of Labor Industrial Code Rule 23 – Protection in Construction, Demolition and Excavation;
- New York City Construction Codes, Title 28
- NYC Department of Transportation Title 34 Chapter 2 – Highway Rules
- New York State Department of Labor Industrial Code Rule 16 NYCRR Part 753
- Title 15 of the Rules of the City of New York, Chapter 13 Citywide Construction Dust Mitigation
- Manual on Uniform Traffic Control Devices (MUTCD)
- Title 15 of the Rules of the City of New York, Chapter 28 Citywide Construction Noise Mitigation

II. PURPOSE

The purpose of this policy is to ensure that Contractors perform their work and supervise their employees in accordance with all applicable federal, state and city rules and regulations. Further, Contractors will be expected to minimize or eliminate jobsite and public hazards, through a planning, inspection, auditing and corrective action process. The goal is to control risks so that injuries, illnesses and accidents to contractors' employees, DDC employees and the general public, as well as damage to city-owned and private property, are reduced to the lowest level feasible.

III. DEFINITIONS

Agency Chief Contracting Officer (ACCO): The ACCO shall mean the person delegated authority by the Commissioner to organize and supervise the procurement activity of subordinate Agency staff in conjunction with the CCPO.

Competent Person: As defined by OSHA, an individual who is capable of identifying existing and predictable hazards in the surroundings or working conditions that are unsanitary, hazardous, or dangerous to employees or the general public, and who has authorization to take prompt corrective measures to eliminate them.

Construction Safety Auditor: A representative of the QA&CS Construction Safety Unit who provides inspection and assessment services to enhance health and safety on all DDC construction projects. The activities of the Construction Safety Auditor include performing site surveys, reviewing health and safety plans, reviewing construction permits, and rendering technical advice and assistance to DDC Resident Engineers and Project Managers.

Construction Safety Unit: A part of QA&CS within the Division of Program Management/ Safety & Site Support that assesses contractor safety on DDC jobsites and advises responsible parties of needed corrective actions.

City of New York Department of Design and Construction: Safety Requirements
Safety and Site Support- Quality Assurance and Construction Safety

Construction Superintendent: A representative of the contractor responsible for overseeing performance of the required construction work. This individual must engage in sound construction practices, and is responsible to maintain a safe work site. In the case of a project involving the demolition, alteration or new construction of buildings, the Construction Superintendent must be licensed by the NYC Department of Buildings.

Contractor: For purposes of these Safety Requirements, the term "Contractor" shall mean any person or entity that enters into a contract for the performance of construction work on a DDC project. The term "Contractor" shall include any person or entity which enters into any of the following types of contracts: (1) a prime construction contract for a specific project, (2) a prime construction contract using the Job Order Contracting System ("JOCS Contract"), and (3) a subcontract with a CM/Builder ("First Tier Subcontract").

Daily Safety Job Briefing: Daily jobsite safety meetings, giving to all jobsite personnel by contractor, with the purpose of discussing project specific safety procedures for the scheduled construction work.

Director - Quality Assurance and Construction Safety (QA&CS): Responsible for the operations of the QACS Construction Safety Unit and the DDC Site Safety management programs.

Job Hazard Analysis (JHA): A process of identifying the major job steps and any potential site-specific hazards that may be present during construction and establishing the means and methods to eliminate or control those hazards.

Qualified Person: As defined by OSHA, an individual who, by possession of a recognized degree, certificate, license or professional standing, or who by extensive knowledge, training, and experience, has successfully demonstrated his or her ability to solve problems relating to the subject matter, the work, or the project. Qualified Persons are required under regulation to address issues pertaining, but without limit, to fall protection, scaffold design and trenching and shoring, among others.

Project Site: Those areas indicated in the Contract Documents where the Work is to be performed.

Project Safety Representative: The designated project safety representative shall have completed an authorized 30 hour OSHA Construction Safety Course and other safety training applicable to Contractor's/subcontractor's project work. Except in instances where a dedicated Project Safety Manager is required, a Project Safety Representative may also function as a superintendent, foreman or crew leader on the Project, but must have sufficient experience and authority to undertake corrective actions and must qualify to be a competent person. No work is to be performed on site when a Project Safety Representative is not present.

Project Safety Manager: A dedicated, full-time project safety manager may be a contractual requirement on large projects or projects deemed by DDC to be particularly high risk. This would be in addition or in lieu of a Contractor's Project Safety Representative. This individual shall not have any other assigned duties. This individual shall have received, at a minimum an authorized 30 hour OSHA Construction Safety Course. Other examples of acceptable training are OSHA Safety and Health Standards for the Construction Industry training program (OSHA 510), Certified Safety Professional (CSP), Certified Industrial Hygienist (CIH) or a degree/certificate in a safety and health from a college-level curriculum.

A Project Safety Manager shall possess the additional training, years of experience, and skills necessary to thoroughly understand the health and safety hazards and controls for large construction projects, including the full scope of the specific Work.

QA&CS - Quality Assurance and Construction Safety of the New York City Department of Design and Construction.

City of New York Department of Design and Construction: Safety Requirements
Safety and Site Support- Quality Assurance and Construction Safety

Resident Engineer (RE) / Construction Project Manager (CPM): Representative of the Commissioner duly designated by the Commissioner to be his/her representative at the site of the work. (The RE/CPM may be a third-party consultant, including a Construction Management firm, retained by DDC)

Safety Program: Established by the Contractor that covers all operations of that Contractor and establishes the Contractor's overall safety policy, regulatory compliance plan and minimum safety standards. The Safety Program must be submitted prior to the commencement of work at the site and is subject to review and acceptance by the Construction Safety Unit.

Safety Questionnaire: Used by DDC to evaluate Contractor's current and past safety performance. It is required to be completed by all Contractors initially when submitting bids for Construction work, or when being pre-qualified and updated annually or as requested by the DDC.

Site Safety Manager: For certain projects, as defined in NYC Construction Codes - Title 28, the Contractor shall provide a Site Safety Manager with a Site Safety Manager License issued by the NYC Department of Building.

Site Safety Plan: A site-specific safety plan developed by the Contractor for a specific project. The Site Safety Plan must identify hazards associated with the project, and include specific safety procedures and training appropriate and necessary to complete the work. The Site Safety Plan must be submitted prior to the commencement of work at the site and is subject to review and acceptance by the Construction Safety Unit.

Unsafe or Unhealthy Condition: A condition that could be potentially hazardous to the health and safety of personnel or the public, and/or damaging to equipment, machinery, property or the environment.

Weekly Safety Meetings: Weekly documented jobsite safety meetings, given to all jobsite personnel by contractor, with the purpose of discussing general safety topics and job specific requirements encountered at the DDC work site.

Work: The construction required by the Contract Documents whether completed or partially completed, performed by the Contractor/ subcontractors. Work refers to the furnishing of labor, furnishing and incorporating materials and equipment into the construction and providing any service required by the Contract Documents to fulfill the Contractor's obligation to complete the Project.

IV. RESPONSIBILITIES

All persons who manage, perform, and provide support for construction projects shall conduct operations in compliance with the requirements identified in this Policy and all applicable governing regulatory agency requirements and guidelines pertaining to safety in construction.

A. DDC or CM Resident Engineer / Construction Project Manager

- Monitors the issuance of safety-related permits, approvals and drawings and maintains copies on site.
- Monitors construction-related work activities to confirm that they are conducted in accordance with DDC policies and all applicable regulations that pertain to construction safety.
- Maintains documentation and periodically attends weekly safety meetings and daily safety job briefings.
- Notifies the Construction Safety Unit and the ACCO's Insurance and Risk Management Unit of project-related accidents and emergencies, as per DDC's Construction Safety Emergency and Accident Notification and Response Protocol.
- Gathers facts related to all accidents and prepares DDC Construction Accident Report.

City of New York Department of Design and Construction: Safety Requirements
Safety and Site Support– Quality Assurance and Construction Safety

- Notifies the Construction Safety Unit within two (2) hours of the start of an inspection by any outside regulatory agency personnel, including OSHA, NYC DOB or others and forwards a copy of the inspection report within three days of its receipt.
- Monitors the conditions at the site for conformance with the contractor's Site Safety Plan and DDC construction documents.
- Notifies the contractor and DDC in the event that any condition or activity exists that is not in compliance with the contractor's Site Safety Plan, applicable federal, state or local codes or any condition that presents a potential risk of injury to the public or workers or possible damage to property.
- Notifies DDC of any unsafe or unhealthy condition and directs the contractor to provide such labor, materials, equipment and supervision to abate such conditions.
- Escort and assist QA&CS Construction Safety Auditors during the field and record inspections.
- Reports emergency conditions to the Construction Safety Unit immediately.

B. Contractors

- Submit a completed Safety Questionnaire and other safety performance related documentation with its bid or as part of a pre-qualification package.
- Complete a written Job Hazard Analysis (JHA) that identifies safety hazards for project specific work tasks and hazard control methods. A written JHA shall be available at the site for reference and included in the Site Safety Plan submitted by the contractor.
- Submit a Site Safety Plan and Safety Program within 30 days from the Award Date or as otherwise directed. The Site Safety Plan and Safety Program are subject to review and acceptance by the Construction Safety Unit prior to the commencement of work at the site. The Site Safety Plan shall be revised and updated as necessary.
- Develop project specific safety procedures to protect general public during all construction activities for the duration of the project.
- Ensure that all employees are aware of the hazards associated with the project through documented formal and informal training and/or other communications. Conduct and document weekly safety meetings and daily job briefing sessions for the duration of the project. Documentation to be provided to the RE/CPM on a monthly basis.
- Name the Project Safety Representative and Project Safety Manager, if required. The Contractor will be required to identify the Project Safety Representative and Project Safety Manager in the Site Safety Plan. Resumes, outlining the qualification and experience for the Project Safety Representative and Project Safety Manager, shall be available upon request. DDC reserves the right to request that the Contractor replace any Project Safety Representative or Project Safety Manager for any reason at any time during the project.
- Name a Competent Person(s), The Contractor will be required to identify a Competent Person(s) in the Site Safety Plan.
- Comply with all mandated federal, state and local safety and health rules and regulations.
- Comply with all provisions of the Site Safety Plan.
- Conduct applicable safety training prior to the commencement of work at the site. All training records (OSHA 10-hour, flagger, scaffold, fall protection, confined space entry, etc.) shall be provided to the RE/CPM prior to mobilization, included in the Site Safety Plan, kept current during the course of the project, and available for review. Prior to performing any work on DDC project all employees shall have successfully completed, within the previous five calendar years, a 10 Hour OSHA construction safety course.
- As part of the Site Safety Plan, prepare a site specific programs and plans, such as MPT plan, steel erection plan, confined space program, fall protection plan, demolition plan, etc. (if not otherwise provided in the contract documents) and comply with all of its provisions.
- Conduct and document site-specific safety orientation for Contractor personnel to review the hazards associated with the project as identified in the Site Safety Plan and the specific safety procedures and

City of New York Department of Design and Construction: Safety Requirements
Safety and Site Support- Quality Assurance and Construction Safety

controls that will be used to protect workers, the general public and property. The Project Safety Representative and/or Project Safety Manager will conduct this training prior to mobilization and provide documentation to the RE/CPM.

- Provide, replace and adequately maintain at or around the project site, suitable and sufficient signage, lights, barricades and enclosures (fences, sidewalk sheds, netting, bracing, etc.).
- Report unsafe or unhealthy conditions to the RE/CPM as soon as practical, but no more than 24 hours after discovery, and take prompt actions to remove or abate such conditions.
- Report any accidents involving injuries to workers or the general public, as well as property damage, to the RE/CPM within one (1) hour.
- Following an accident, the Contractor shall not remove or alter any equipment, structure, material, or evidence related to the accident. Exception: Immediate emergency procedures taken to secure structures, temporary construction, operations, or equipment that pose a continued imminent danger or facilitate assistance for persons who are trapped or who have sustained bodily injury.
- Notify the RE/CPM within one (1) hour of the start of an inspection by any outside regulatory agency personnel, including OSHA, NYC DOB or others.
- Maintain all records pertaining to all required compliance documents and accident and injury reports.
- Address DDC recommendations on safety, which shall in no way relieve the Contractor of its responsibilities for safety on the project. The Contractor has sole responsibility for safety.

V. SAFETY QUESTIONNAIRE

DDC requires that all Contractors provide information regarding their current and past safety performance and programs. This will be accomplished by the use of the DDC Safety Questionnaire. As a part of the bid submittal package, the contractor must submit a completed DDC Safety Questionnaire listing company workers' compensation experience modification rating and OSHA Incident Rates for the three (3) years prior to the date of the bid opening. DDC may request a Contractor to update its Questionnaire at any time or to provide more detailed information. The Contractor must provide the requested information within 15 days.

The following criteria will be used by DDC in reviewing the Contractor's responsibility, which will be based on the information provided on the questionnaire:

- Criteria 1: OSHA Injury and Illness Rates (I&IR) are no greater than the average for the industry (based on the most current Bureau of Labor Statistics data for the Contractors SIC code); and
- Criteria 2: Insurance workers compensation Experience Modification Rate (EMR) equal to or less than 1.0; and
- Criteria 3: Any willful violations issued by OSHA or NYC DOB within the last three (3) years; and
- Criteria 4: A fatality (worker or member of public) and injuries, requiring OSHA notification, experienced on or near Contractor's worksite within the last three (3) years; and
- Criteria 5: Past safety performance on DDC projects (accidents; status of safety program and site safety plan submittals; etc.)
- Criteria 6: OSHA violation history for the last three (3) years;
- Criteria 7: Contractor shall provide OSHA Injury and Illness Records (currently OSHA 300 and 300A Logs) for the last three (3) years.

If the Contractor fails to meet the basic criteria listed above, the Construction Safety Unit may request, through the ACCO, more details concerning the Contractor's safety experience. DDC may request the Contractor to provide copies of, among other things, accident investigation reports, OSHA records, OSHA and NYC DOB citations, EPA citations and written corrective action plan.

City of New York Department of Design and Construction: Safety Requirements
Safety and Site Support- Quality Assurance and Construction Safety

VI. SAFETY PROGRAM AND SITE SAFETY PLAN

Within thirty (30) days from the Award Date, or as otherwise directed, the Contractor shall submit the following: (1) Safety Program, and (2) Site Safety Plan. The Safety Program shall set forth the Contractor's overall safety policy, regulatory compliance plan and minimum safety standards. The Site Safety Plan shall identify project work scope, safety hazards associated with the project tasks, and include specific safety procedures and training appropriate and necessary to complete the work. The Safety Program and the Site Safety Plan are subject to review and acceptance by the Construction Safety Unit prior to the commencement of work at the site. Failure by the Contractor to submit an acceptable Site Safety Plan and Safety Program shall be grounds for default.

Safety Program: Corporate Safety Program established by the Contractor that includes the Contractor's overall safety policy, regulatory compliance plan and basic safety procedures covering all aspects of construction operations, performed by the Contractor. The Safety Program shall be a written document with a separate section describing each element of the Safety Program. The Safety Program shall have at minimum the following elements applicable to the Contractor's operations:

- Responsibility and Organization – Contractor's company organization chart, including titles, names, contact information, roles and responsibilities for key personnel, etc.
- Safety Training Program – Contractor's corporate training program.
- Hazard Corrective Actions – Criteria for safety inspections, identification of safety non-compliances, implementation and verification of corrective actions, forms to document safety inspections results, etc.
- Accident/Exposure Investigation
- Recordkeeping and Reporting Injuries – Responsible staff; reporting and recording criteria; OSHA 300 and 300A form completion, etc.
- Fire Protection and Prevention Program
- Housekeeping
- Illumination
- Sanitation
- Personal Protective Equipment (PPE) – Company policy for the use of head protection, foot protection, hearing protection, eye and face protection, protective clothing, and any additional protective equipment based on work tasks; PPE inspection and replacement policy.
- Hazard Communication Program
- Employee Emergency Action Plan
- Protection of Underground Facilities and Utilities
- Ionizing/Nonionizing Radiation
- Material Handling, Storage, Use and Disposal
- Tools – Hand and Power
- Signs, Signals, and Barricades
- Scaffold – Local Law 52 requirements, installation, use, inspection, dismantling, training and general safety requirements.
- Welding and Cutting
- Electrical Safety
- Fall Protection
- Cranes, Derrick, Hoists, Elevators, Conveyors
- Excavation Safety
- Concrete and Masonry Construction
- Maintenance and Protection of Traffic
- Steel Erection
- Demolition
- Blasting and the Use of Explosives
- Stairways and Ladders

City of New York Department of Design and Construction: Safety Requirements
Safety and Site Support– Quality Assurance and Construction Safety

- Toxic and Hazardous Substances
- Alcohol and Drug Abuse Policy
- Rodents and Vermin
- Occupational Noise Exposure
- Confined Space Program – General confined Space Program: training requirements, confined space hazard evaluation procedure, atmospheric testing procedure, confined space classification, permit-required procedure, communication procedure, rescue procedure, forms, etc.
- Construction Vehicles/Heavy Equipment
- Dust Control Procedures

Site Safety Plan: The Site Safety Plan shall be a written document and shall apply to all project specific Contractor and subcontractor operations, and shall have at a minimum, the following elements with each element described in a separate section (It may be necessary to modify the basic format for certain unique or high-risk projects, such as tunnels or high-rise construction):

- Project Work Scope – Detailed information regarding work tasks that will be performed by contractor and subcontractors under the project.
- Responsibility and Organization – Contractor’s organization chart with responsible staff for the project, including titles, names, contact information, roles and responsibilities.
- Safety Training and Education – OSHA 10 Hours training, requirements for daily safety briefings and weekly safety meetings, any work task specific training, responsible staff for implementation of training program for the project.
- Job Hazard Analysis (JHA) – Project specific Job Hazard Analysis including work tasks, identified hazards, hazard control methods (administrative, engineering, PPE), contractor’s name, project id, location, name and signature of a certifying person, hazard assessment date.
- Protection of Public
- Hazard Corrective Actions – Responsible staff, forms, frequency of safety inspections and implementation of corrective actions.
- Accident/Exposure Investigation – Accident/incident notification procedure of DDC project staff. Project specific procedures for accident investigation and implementation of corrective actions.
- First Aid and Medical Attention – Responsible staff, location and inspection of First Aid kit, directions to local hospitals; emergency telephone numbers.
- Project Specific Fire Protection and Prevention Program.
- Project Specific Illumination Procedure.
- Project Specific Sanitation Procedure.
- Personal Protective Equipment (PPE)
- Hazard Communication Program – Responsible staff; training; SDS records, project specific list of chemical; location of the program and SDS records.
- Means of Egress – Information regarding free and unobstructed egress from all parts of the building or structure; exit marking; maintenance of means of egress, etc.
- Employee Emergency Action Plan – Project specific: responsible staff, emergency alarm system, evacuation procedure, procedure to account for employees after evacuation, etc.
- Evacuation Plan – Project specific evacuation plan (drawing/scheme) with exists and evacuation routes.
- Protection of Underground Facilities and Utilities, including responsible staff.
- Ionizing/Nonionizing Radiation – Competent person, license and qualification requirements, type of radiation, employees exposure and protection, etc.
- Material Handling, Storage, Use and Disposal – Project specific information regarding material storage and disposal.
- Signs, Signals, and Barricades – Use of danger/warning signs, sidewalk closure, safety instruction signs, pedestrian fencing and barricades, etc.
- Scaffold – Project specific scaffold types, training, scaffold drawings, competent person, criteria for project specific scaffold, falling object protection.

City of New York Department of Design and Construction: Safety Requirements
Safety and Site Support– Quality Assurance and Construction Safety

- Welding and Cutting – project specific procedure for welding and cutting, including all necessary safety requirements such as fire prevention, personal protective equipment, hot work permits, FDNY certificate requirements.
- Fall Protection – Project specific information regarding selected fall protection systems, fall protection plan.
- Cranes, Derrick, Hoists, Elevators, Conveyors – project specific equipment information including type, rated load capacity, manufacture specification requirements, competent person, exposure to falling load, inspection, recordkeeping, clearance requirements, communication procedure, ground lines, permits.
- Excavation Safety – Competent person, project specific protective system.
- Maintenance and Protection of Traffic Plan – Project specific MPT plan, flagmen training.
- Steel Erection – Site specific erection plan, requirements for applicable written notifications, competent person.
- Demolition – Engineering survey, including written evidence, disconnection of all effected utilities, identification of all hazardous chemicals, materials, gases, etc., floor openings, chutes, inspection and maintenance of all stairs/passageways, removal of materials/debris/structural elements, lock out/tag out, competent person.
- Blasting and the Use of Explosives – Project specific safety procedures, warning signs, training/qualification, transportation, storage and use of explosives, inspection.
- Toxic and Hazardous Substances – Safety procedures for substances to be used on project.
- Noise Mitigation Plan – Completed project specific Noise Mitigation Plan.
- Confined Space Program – Project specific Confined Space Program, responsible staff, training records, equipment information, rescue procedure, list of project specific confined spaces, forms.
- Construction Vehicles/Heavy Equipment – Type of construction vehicles/heavy equipment to be used on site.
- Dust Mitigation Plan – Completed project specific Dust Mitigation Plan.

The most critical component of the Site Safety Plan is the Job Hazard Analysis (JHA) section. The JHA form is a written document prepared by the contractor. The contractor must conduct a site and task assessment JHA to identify the major job steps and any potential safety or environmental hazards related to performance of the work, eliminate or implement controls for the potential hazards, and identify proper personal protective equipment for the task. The JHA shall be communicated to all contractor/subcontractor personnel on site.

The initial Job Hazard Assessment form shall be included in the contractor's Site Safety Plan and the current form shall be available at the construction site for reference.

Certain DDC programs, such as Job Order Contracting System (JOCS), may not necessarily require Site Safety Plans. The JOCS contractor shall submit a Safety Program. The Site Safety Plan requirement for the JOCS contractor will be determined by QA&CS based on a project work scope, construction activities and project location. In addition, certain DDC Operating Units may establish client-specific program or safety requirements. The contractor's Site Safety Plan must address such client-specific program or safety requirements.

VII. KICK-OFF MEETINGS/PRE-CONSTRUCTION AND SAFETY REVIEW

RE/CPM shall invite QA&CS Construction Safety Unit to the construction kick-off meeting. A QA&CS representative will participate in this meeting with the Contractor and RE/CPM prior to the start of the project for the purpose of:

- A. Reviewing the safety issues detailed in the contract.
- B. Reviewing the Site Safety Plan.
- C. Reviewing any new issues or information that was not previously addressed.
- D. Discussing planned inspections and audits of the site by QA&CS personnel.

City of New York Department of Design and Construction: Safety Requirements
Safety and Site Support– Quality Assurance and Construction Safety

VIII. EVALUATION DURING WORK IN PROGRESS

The Contractor's adherence to these Safety Requirements will be monitored throughout the project. This will be accomplished by the following:

- A. Use of a safety checklist by a representative of the Construction Safety Unit or other designated DDC representative or Consultant during regular, unannounced inspections of the job site. Field Exit Conferences will be held with the RE/CPM, Contractor Project Safety Representatives.
- B. The RE/CPM will continually monitor the safety and environmental performance of the contractor's employees and work methods. Deficiencies shall be brought to the attention of the contractor's representative on site for immediate correction. The DDC representative will maintain a written record of these deficiencies and have these records available upon request. Any critical deficiencies shall be immediately reported to QA&CS phone# (718) 391-1624 or (718) 391-1911.
- C. If the Contractor's safety performance during the project is not up to DDC standards (safety performance measure, accident/incident rate, etc.) the Director – QA&CS, or his/her designee will meet with the Contractor's Project Safety Representative and or Project Safety Manager, the DDC Project Manager, the RE/CPM, and the DDC Environmental Specialist (if environmental issues are involved). The purpose of this meeting is to 1) determine the level of non-compliance; 2) explain and clarify the safety/environmental provisions; 3) agree on a future course of action to correct the deficiencies.
- D. If the deficiencies continue to occur with inadequate attention by the contractor, this shall, among other remedies available, be grounds for default.
- E. The contractor shall within 1 hour inform the RE/CPM/CM of all accidents/incidents including all fatalities, any injuries to employees or members of the general public, and property damage (e.g., structural damage, equipment rollovers, utility damage, loads dropped from crane). The RE/CPM shall notify the Construction Safety Unit as per DDC's Construction Safety Emergency and Accident Notification and Response Protocol and shall maintain a record of all contractor accidents/incidents for the project.
- F. The Construction Safety Unit shall be notified within two (2) hours of the start of any NYS-DOL/ NYC-COSH/ OSHA/ EPA inspections.

IX. SAFETY PERFORMANCE EVALUATION

The contractor's safety record, including accident/incident history and DDC safety inspection results, will be considered as part of the Contractor's performance evaluation at the conclusion of the project. Poor safety performance during the course of the project shall be a reason to rate a Contractor unsatisfactory which may be reflected in the City's Vendex system and will be considered for future procurement actions as set forth in the City's Procurement Policy Board Rules.

CITY OF NEW YORK
STANDARD CONSTRUCTION CONTRACT

March 2017

(NO TEXT ON THIS PAGE)

**CITY OF NEW YORK
STANDARD CONSTRUCTION CONTRACT**

TABLE OF CONTENTS

CHAPTER I: THE CONTRACT AND DEFINITIONS	1
ARTICLE 1. THE CONTRACT	1
ARTICLE 2. DEFINITIONS	1
CHAPTER II: THE WORK AND ITS PERFORMANCE	4
ARTICLE 3. CHARACTER OF THE WORK	4
ARTICLE 4. MEANS AND METHODS OF CONSTRUCTION	4
ARTICLE 5. COMPLIANCE WITH LAWS	5
ARTICLE 6. INSPECTION	10
ARTICLE 7. PROTECTION OF WORK AND OF PERSONS AND PROPERTY; NOTICES AND INDEMNIFICATION	11
CHAPTER III: TIME PROVISIONS	12
ARTICLE 8. COMMENCEMENT AND PROSECUTION OF THE WORK	12
ARTICLE 9. PROGRESS SCHEDULES	13
ARTICLE 10. REQUESTS FOR INFORMATION OR APPROVAL	13
ARTICLE 11. NOTICE OF CONDITIONS CAUSING DELAY AND DOCUMENTATION OF DAMAGES CAUSED BY DELAY	14
ARTICLE 12. COORDINATION WITH OTHER CONTRACTORS	18
ARTICLE 13. EXTENSION OF TIME FOR PERFORMANCE	19
ARTICLE 14. COMPLETION AND FINAL ACCEPTANCE OF THE WORK	21
ARTICLE 15. LIQUIDATED DAMAGES	23
ARTICLE 16. OCCUPATION OR USE PRIOR TO COMPLETION	23
CHAPTER IV: SUBCONTRACTS AND ASSIGNMENTS	24
ARTICLE 17. SUBCONTRACTS	24
ARTICLE 18. ASSIGNMENTS	26
CHAPTER V: CONTRACTOR'S SECURITY AND GUARANTEE	26
ARTICLE 19. SECURITY DEPOSIT	26
ARTICLE 20. PAYMENT GUARANTEE	27
ARTICLE 21. RETAINED PERCENTAGE	29
ARTICLE 22. INSURANCE	30
ARTICLE 23. MONEY RETAINED AGAINST CLAIMS	36
ARTICLE 24. MAINTENANCE AND GUARANTY	37
CHAPTER VI: CHANGES, EXTRA WORK, AND DOCUMENTATION OF CLAIM	38
ARTICLE 25. CHANGES	38
ARTICLE 26. METHODS OF PAYMENT FOR OVERRUNS AND EXTRA WORK	38
ARTICLE 27. RESOLUTION OF DISPUTES	41
ARTICLE 28. RECORD KEEPING FOR EXTRA OR DISPUTED WORK OR WORK ON A TIME & MATERIALS BASIS	45
ARTICLE 29. OMITTED WORK	46
ARTICLE 30. NOTICE AND DOCUMENTATION OF COSTS AND DAMAGES; PRODUCTION OF FINANCIAL RECORDS	46
CHAPTER VII: POWERS OF THE RESIDENT ENGINEER, THE ENGINEER OR ARCHITECT AND THE COMMISSIONER	48
ARTICLE 31. THE RESIDENT ENGINEER	48
ARTICLE 32. THE ENGINEER OR ARCHITECT OR PROJECT MANAGER	48
ARTICLE 33. THE COMMISSIONER	48
ARTICLE 34. NO ESTOPPEL	49
CHAPTER VIII: LABOR PROVISIONS	49
ARTICLE 35. EMPLOYEES	49
ARTICLE 36. NO DISCRIMINATION	57
ARTICLE 37. LABOR LAW REQUIREMENTS	59

ARTICLE 38. PAYROLL REPORTS	64
ARTICLE 39. DUST HAZARDS	64
CHAPTER IX: PARTIAL AND FINAL PAYMENTS	65
ARTICLE 40. CONTRACT PRICE	65
ARTICLE 41. BID BREAKDOWN ON LUMP SUM.....	65
ARTICLE 42. PARTIAL PAYMENTS	65
ARTICLE 43. PROMPT PAYMENT	66
ARTICLE 44. SUBSTANTIAL COMPLETION PAYMENT.....	66
ARTICLE 45. FINAL PAYMENT.....	67
ARTICLE 46. ACCEPTANCE OF FINAL PAYMENT.....	68
ARTICLE 47. APPROVAL BY PUBLIC DESIGN COMMISSION.....	69
CHAPTER X: CONTRACTOR'S DEFAULT	69
ARTICLE 48. COMMISSIONER'S RIGHT TO DECLARE CONTRACTOR IN DEFAULT	69
ARTICLE 49. EXERCISE OF THE RIGHT TO DECLARE DEFAULT	71
ARTICLE 50. QUITTING THE SITE.....	71
ARTICLE 51. COMPLETION OF THE WORK.....	71
ARTICLE 52. PARTIAL DEFAULT	71
ARTICLE 53. PERFORMANCE OF UNCOMPLETED WORK.....	72
ARTICLE 54. OTHER REMEDIES.....	72
CHAPTER XI: MISCELLANEOUS PROVISIONS	72
ARTICLE 55. CONTRACTOR'S WARRANTIES.....	72
ARTICLE 56. CLAIMS AND ACTIONS THEREON.....	73
ARTICLE 57. INFRINGEMENT	73
ARTICLE 58. NO CLAIM AGAINST OFFICIALS, AGENTS OR EMPLOYEES.....	74
ARTICLE 59. SERVICE OF NOTICES	74
ARTICLE 60. UNLAWFUL PROVISIONS DEEMED STRICKEN FROM CONTRACT.....	74
ARTICLE 61. ALL LEGAL PROVISIONS DEEMED INCLUDED	74
ARTICLE 62. TAX EXEMPTION	74
ARTICLE 63. INVESTIGATION(S) CLAUSE.....	76
ARTICLE 64. TERMINATION BY THE CITY	78
ARTICLE 65. CHOICE OF LAW, CONSENT TO JURISDICTION AND VENUE.....	80
ARTICLE 66. PARTICIPATION IN AN INTERNATIONAL BOYCOTT	81
ARTICLE 67. LOCALLY BASED ENTERPRISE PROGRAM	82
ARTICLE 68. ANTITRUST	82
ARTICLE 69. MACBRIDE PRINCIPLES PROVISIONS	83
ARTICLE 70. ELECTRONIC FILING/NYC DEVELOPMENT HUB	85
ARTICLE 71. PROHIBITION OF TROPICAL HARDWOODS.....	85
ARTICLE 72. CONFLICTS OF INTEREST.....	85
ARTICLE 73. MERGER CLAUSE	85
ARTICLE 74. STATEMENT OF WORK.....	85
ARTICLE 75. COMPENSATION TO BE PAID TO CONTRACTOR	85
ARTICLE 76. ELECTRONIC FUNDS TRANSFER.....	85
ARTICLE 77. RECORDS RETENTION.....	86
ARTICLE 78. EXAMINATION AND VIEWING OF SITE, CONSIDERATION OF OTHER SOURCES OF INFORMATION AND CHANGED SITE CONDITIONS.....	86

**ARTICLE 79: PARTICIPATION BY MINORITY-OWNED AND WOMEN-OWNED
BUSINESS ENTERPRISES IN CITY PROCUREMENT87**

SIGNATURES95

ACKNOWLEDGMENT BY CORPORATION96

ACKNOWLEDGMENT BY PARTNERSHIP.....96

ACKNOWLEDGMENT BY INDIVIDUAL96

ACKNOWLEDGMENT BY COMMISSIONER97

AUTHORITY98

COMPTROLLER'S CERTIFICATE98

MAYOR'S CERTIFICATE99

PERFORMANCE-BOND #1100

PERFORMANCE BOND #2.....104

PAYMENT BOND108

(NO TEXT ON THIS PAGE)

WITNESSETH:

The parties, in consideration of the mutual agreements contained herein, agree as follows:

CHAPTER I: THE CONTRACT AND DEFINITIONS

ARTICLE 1. THE CONTRACT

1.1 Except for titles, subtitles, headings, running headlines, tables of contents and indices (all of which are printed herein merely for convenience), the following, except for such portions thereof as may be specifically excluded, shall be deemed to be part of this Contract:

1.1.1 All provisions required by law to be inserted in this Contract, whether actually inserted or not;

1.1.2 The Contract Drawings and Specifications;

1.1.3 The General Conditions and Special Conditions, if any;

1.1.4 The Contract;

1.1.5 The Information for Bidders; Request for Proposals; Notice of Solicitation and Proposal For Bids; Bid or Proposal, and, if used, the Bid Booklet;

1.1.6 All Addenda issued prior to the receipt of the bids; the Notice of Award; Performance and Payment Bonds, if required; and the Notice to Proceed or the Order to Work.

1.2 Should any conflict occur in or between the Drawings and Specifications, the Contractor shall be deemed to have estimated the most expensive way of doing the Work, unless the Contractor shall have asked for and obtained a decision in writing from the Commissioner of the Agency that is entering into this Contract, before the submission of its bid, as to what shall govern.

ARTICLE 2. DEFINITIONS

2.1 The following words and expressions, or pronouns used in their stead, shall, wherever they appear in this Contract, be construed as follows, unless a different meaning is clear from the context:

2.1.1 "Addendum" or "Addenda" shall mean the additional Contract provisions and/or technical clarifications issued in writing by the Commissioner prior to the receipt of bids.

2.1.2 "Agency" shall mean a city, county, borough or other office, position, department, division, bureau, board or commission, or a corporation, institution or agency of government, the expenses of which are paid in whole or in part from the City treasury.

2.1.3 "Agency Chief Contracting Officer" (ACCO) shall mean a person delegated authority by the Commissioner to organize and supervise the procurement activity of subordinate Agency staff in conjunction with the CCPO, or his/her duly authorized representative.

2.1.4 "Allowance" shall mean a sum of money which the Agency may include in the total amount of the Contract for such specific contingencies as the Agency believes may be necessary to complete the Work, e.g., lead or asbestos remediation, and for which the Contractor will be paid on the basis of stipulated unit prices or a formula set forth in the Contract or negotiated between the parties provided, however, that if the Contractor is not directed to use the Allowance, the Contractor shall have no right to such money and it shall be deducted from the total amount of the Contract.

2.1.5 "City" shall mean the City of New York.

2.1.6 "City Chief Procurement Officer" (CCPO) shall mean a person delegated authority by the Mayor to coordinate and oversee the procurement activity of Mayoral agency staff, including the ACCO and any offices which have oversight responsibility for the procurement of construction, or his/her duly authorized representative.

2.1.7 "Commissioner" shall mean the head of the Agency that has entered into this Contract, or his/her duly authorized representative.

2.1.8 "Comptroller" shall mean the Comptroller of the City of New York.

2.1.9 "Contract" or "Contract Documents" shall mean each of the various parts of the contract referred to in Article 1 hereof, both as a whole and severally.

2.1.10 "Contract Drawings" shall mean only those drawings specifically entitled as such and listed in the Specifications or in any Addendum, or any drawings furnished by the Commissioner, pertaining or supplemental thereto.

2.1.11 "Contract Work" shall mean everything required to be furnished and done by the Contractor by any one or more of the parts of the Contract referred to in Article 1, except Extra Work as hereinafter defined.

2.1.12 "Contractor" shall mean the entity which executed this Contract, whether a corporation, firm, partnership, joint venture, individual, or any combination thereof, and its, their, his/her successors, personal representatives, executors, administrators, and assigns, and any person, firm, partnership, joint venture, individual, or corporation which shall at any time be substituted in the place of the Contractor under this Contract.

2.1.13 "Days" shall mean calendar days, except where otherwise specified.

2.1.14 "Engineer" or "Architect" or "Project Manager" shall mean the person so designated in writing by the Commissioner in the Notice to Proceed or the Order to Work to act as such in relation to this Contract, including a private Architect or Engineer or Project Manager, as the case may be. Subject to written approval by the Commissioner, the Engineer, Architect or Project Manager may designate an authorized representative.

2.1.15 "Engineering Audit Officer" (EAO) shall mean the person so designated by the Commissioner to perform responsible auditing functions hereunder.

2.1.16 "Extra Work" shall mean Work other than that required by the Contract at the time of award which is authorized by the Commissioner pursuant to Chapter VI of this Contract.

- 2.1.17 "Federal-Aid Contract" shall mean a contract in which the United States (federal) Government provides financial funding as so designated in the Information for Bidders.
- 2.1.18 "Final Acceptance" shall mean final written acceptance of all the Work by the Commissioner, a copy of which shall be sent to the Contractor.
- 2.1.19 "Final Approved Punch List" shall mean a list, approved pursuant to Article 14.2.2, specifying those items of Work to be completed by the Contractor after Substantial Completion and dates for the completion of each item of Work.
- 2.1.20 "Law" or "Laws" shall mean the Constitution of the State of New York, the New York City Charter, the New York City Administrative Code, a statute of the United States or of the State of New York, a local law of the City of New York, any ordinance, rule or regulation having the force of law, or common law.
- 2.1.21 "Materialman" shall mean any corporation, firm, partnership, joint venture, or individual, other than employees of the Contractor, who or which contracts with the Contractor or any Subcontractor, to fabricate or deliver, or who actually fabricates or delivers, plant, materials or equipment to be incorporated in the Work.
- 2.1.22 "Means and Methods of Construction" shall mean the labor, materials, temporary structures, tools, plant, and construction equipment, and the manner and time of their use, necessary to accomplish the result intended by this Contract.
- 2.1.23 "Notice to Proceed" or "Order to Work" shall mean the written notice issued by the Commissioner specifying the time for commencement of the Work and the Engineer, Architect or Project Manager.
- 2.1.24 "Other Contractor(s)" shall mean any contractor (other than the entity which executed this Contract or its Subcontractors) who or which has a contract with the City for work on or adjacent to the building or Site of the Work.
- 2.1.25 "Payroll Taxes" shall mean State Unemployment Insurance (SUI), Federal Unemployment Insurance (FUI), and payments pursuant to the Federal Insurance Contributions Act (FICA).
- 2.1.26 "Project" shall mean the public improvement to which this Contract relates.
- 2.1.27 "Procurement Policy Board" (PPB) shall mean the Agency of the City of New York whose function is to establish comprehensive and consistent procurement policies and rules which shall have broad application throughout the City.
- 2.1.28 "Required Quantity" in a unit price Contract shall mean the actual quantity of any item of Work or materials which is required to be performed or furnished in order to comply with the Contract.
- 2.1.29 "Resident Engineer" shall mean the representative of the Commissioner duly designated by the Commissioner to be his/her representative at the site of the Work.
- 2.1.30 "Site" shall mean the area upon or in which the Contractor's operations are carried on, and such other areas adjacent thereto as may be designated as such by the Engineer.

2.1.31 "Small Tools" shall mean items that are ordinarily required for a worker's job function, including but not limited to, equipment that ordinarily has no licensing, insurance or substantive storage costs associated with it; such as circular and chain saws, impact drills, threaders, benders, wrenches, socket tools, etc.

2.1.32 "Specifications" shall mean all of the directions, requirements, and standards of performance applying to the Work as hereinafter detailed and designated under the Specifications.

2.1.33 "Subcontractor" shall mean any person, firm or corporation, other than employees of the Contractor, who or which contracts with the Contractor or with its subcontractors to furnish, or actually furnishes labor; or labor and materials, or labor and equipment, or superintendence, supervision and/or management at the Site. Wherever the word Subcontractor appears, it shall also mean sub-Subcontractor.

2.1.34 "Substantial Completion" shall mean the written determination by the Engineer that the Work required under this Contract is substantially, but not entirely, complete and the approval of the Final Approved Punch List.

2.1.35 "Work" shall mean all services required to complete the Project in accordance with the Contract Documents, including without limitation, labor, material, superintendence, management, administration, equipment, and incidentals, and obtaining any and all permits, certifications and licenses as may be necessary and required to complete the Work, and shall include both Contract Work and Extra Work.

CHAPTER II: THE WORK AND ITS PERFORMANCE

ARTICLE 3. CHARACTER OF THE WORK

3.1 Unless otherwise expressly provided in the Contract Drawings, Specifications, and Addenda, the Work shall be performed in accordance with the best modern practice, utilizing, unless otherwise specified in writing, new and unused materials of standard first grade quality and workmanship and design of the highest quality, to the satisfaction of the Commissioner.

ARTICLE 4. MEANS AND METHODS OF CONSTRUCTION

4.1 Unless otherwise expressly provided in the Contract Drawings, Specifications, and Addenda, the Means and Methods of Construction shall be such as the Contractor may choose; subject, however, to the Engineer's right to reject the Means and Methods of Construction proposed by the Contractor which in the opinion of the Engineer:

4.1.1 Will constitute or create a hazard to the Work, or to persons or property; or

4.1.2 Will not produce finished Work in accordance with the terms of the Contract; or

4.1.3 Will be detrimental to the overall progress of the Project.

4.2 The Engineer's approval of the Contractor's Means and Methods of Construction, or his/her failure to exercise his/her right to reject such means or methods, shall not relieve the Contractor

of its obligation to complete the Work as provided in this Contract; nor shall the exercise of such right to reject create a cause of action for damages.

ARTICLE 5. COMPLIANCE WITH LAWS

5.1 The Contractor shall comply with all Laws applicable to this Contract and to the Work to be done hereunder.

5.2 Procurement Policy Board Rules: This Contract is subject to the Rules of the PPB ("PPB Rules") in effect at the time of the bid opening for this Contract. In the event of a conflict between the PPB Rules and a provision of this Contract, the PPB Rules shall take precedence.

5.3 Noise Control Code provisions.

5.3.1 In accordance with the provisions of Section 24-216(b) of the Administrative Code of the City ("Administrative Code"), Noise Abatement Contract Compliance, devices and activities which will be operated, conducted, constructed or manufactured pursuant to this Contract and which are subject to the provisions of the City Noise Control Code shall be operated, conducted, constructed, or manufactured without causing a violation of the Administrative Code. Such devices and activities shall incorporate advances in the art of noise control development for the kind and level of noise emitted or produced by such devices and activities, in accordance with regulations issued by the Commissioner of the City Department of Environmental Protection.

5.3.2 The Contractor agrees to comply with Section 24-219 of the Administrative Code and implementing rules codified at 15 Rules of the City of New York ("RCNY") Section 28-100 *et seq.* In accordance with such provisions, the Contractor, if the Contractor is the responsible party under such regulations, shall prepare and post a Construction Noise Mitigation Plan at each Site, in which the Contractor shall certify that all construction tools and equipment have been maintained so that they operate at normal manufacturers operating specifications. If the Contractor cannot make this certification, it must have in place an Alternative Noise Mitigation Plan approved by the City Department of Environmental Protection. In addition, the Contractor's certified Construction Noise Mitigation Plan is subject inspection by the City Department of Environmental Protection in accordance with Section 28-101 of Title 15 of RCNY. No Contract Work may take place at a Site unless there is a Construction Noise Mitigation Plan or approved Alternative Noise Mitigation Plan in place. In addition, the Contractor shall create and implement a noise mitigation training program. Failure to comply with these requirements may result in fines and other penalties pursuant to the applicable provisions of the Administrative Code and RCNY.

5.4 Ultra Low Sulfur Diesel Fuel: In accordance with the provisions of Section 24-163.3 of the Administrative Code, the Contractor specifically agrees as follows:

5.4.1 Definitions: For purposes of this Article 5.4, the following definitions apply:

5.4.1(a) "Contractor" means any person or entity that enters into a Public Works Contract with a City Agency, or any person or entity that enters into an agreement with such person or entity, to perform work or provide labor or services related to such Public Works Contract.

5.4.1(b) "Motor Vehicle" means any self-propelled vehicle designed for transporting persons or property on a street or highway.

5.4.1(c) "Nonroad Engine" means an internal combustion engine (including the fuel system) that is not used in a Motor Vehicle or a vehicle used solely for competition, or that is not subject to standards promulgated under Section 7411 or Section 7521 of Title 42 of the United States Code, except that this term shall apply to internal combustion engines used to power generators, compressors or similar equipment used in any construction program or project.

5.4.1(d) "Nonroad Vehicle" means a vehicle that is powered by a Nonroad Engine, fifty (50) horsepower and greater, and that is not a Motor Vehicle or a vehicle used solely for competition, which shall include, but not be limited to, excavators, backhoes, cranes, compressors, generators, bulldozers, and similar equipment, except that this term shall not apply to horticultural maintenance vehicles used for landscaping purposes that are powered by a Nonroad Engine of sixty-five (65) horsepower or less and that are not used in any construction program or project.

5.4.1(e) "Public Works Contract" means a contract with a City Agency for a construction program or project involving the construction, demolition, restoration, rehabilitation, repair, renovation, or abatement of any building, structure, tunnel, excavation, roadway, park or bridge; a contract with a City Agency for the preparation for any construction program or project involving the construction, demolition, restoration, rehabilitation, repair, renovation, or abatement of any building, structure, tunnel, excavation, roadway, park or bridge; or a contract with a City Agency for any final work involved in the completion of any construction program or project involving the construction, demolition, restoration, rehabilitation, repair, renovation, or abatement of any building, structure, tunnel, excavation, roadway, park or bridge.

5.4.1(f) "Ultra Low Sulfur Diesel Fuel" means diesel fuel that has a sulfur content of no more than fifteen parts per million (15 ppm).

5.4.2 Ultra Low Sulfur Diesel Fuel

5.4.2(a) All Contractors shall use Ultra Low Sulfur Diesel Fuel in diesel-powered Nonroad Vehicles in the performance of this Contract.

5.4.2(b) Notwithstanding the requirements of Article 5.4.2(a), Contractors may use diesel fuel that has a sulfur content of no more than thirty parts per million (30 ppm) to fulfill the requirements of this Article 5.4.2, where the Commissioner of the City Department of Environmental Protection ("DEP Commissioner") has issued a determination that a sufficient quantity of Ultra Low Sulfur Diesel Fuel is not available to meet the needs of Agencies and Contractors. Any such determination shall expire after six (6) months unless renewed.

5.4.2(c) Contractors shall not be required to comply with this Article 5.4.2 where the City Agency letting this Contract makes a written finding, which is approved, in writing, by the DEP Commissioner, that a sufficient quantity of Ultra Low Sulfur Diesel Fuel, or diesel fuel that has a sulfur content of no more than thirty parts per million (30 ppm) is not available to meet the requirements of Section 24-163.3 of the Administrative Code, provided that such Contractor in its fulfillment of the

requirements of this Contract, to the extent practicable, shall use whatever quantity of Ultra Low Sulfur Diesel Fuel or diesel fuel that has a sulfur content of no more than thirty parts per million (30 ppm) is available. Any finding made pursuant to this Article 5.4.2(c) shall expire after sixty (60) Days, at which time the requirements of this Article 5.4.2 shall be in full force and effect unless the City Agency renews the finding in writing and such renewal is approved by the DEP Commissioner.

5.4.2(d) Contractors may check on determinations and approvals issued by the DEP Commissioner pursuant to Section 24-163.3 of the Administrative Code, if any, at www.dep.nyc.gov or by contacting the City Agency letting this Contract.

5.4.2(e) The requirements of this Article 5.4.2 do not apply where they are precluded by federal or State funding requirements or where the Contract is an emergency procurement.

5.4.3 Best Available Technology

5.4.3(a) All Contractors shall utilize the best available technology for reducing the emission of pollutants for diesel-powered Nonroad Vehicles in the performance of this Contract. For determinations of best available technology for each type of diesel-powered Nonroad Vehicle, Contractors shall comply with the regulations of the City Department of Environmental Protection, as and when adopted, Chapter 14 of Title 15 of the Rules of the City of New York (RCNY). The Contractor shall fully document all steps in the best available technology selection process and shall furnish such documentation to the City Agency or the DEP Commissioner upon request. The Contractor shall retain all documentation generated in the best available technology selection process for as long as the selected best available technology is in use.

5.4.3(b) No Contractor shall be required to replace best available technology for reducing the emission of pollutants or other authorized technology utilized for a diesel-powered Nonroad Vehicle in accordance with the provisions of this Article 5.4.3 within three (3) years of having first utilized such technology for such vehicle.

5.4.3(c) This Article 5.4.3 shall not apply to any vehicle used to satisfy the requirements of a specific Public Works Contract for fewer than twenty (20) Days.

5.4.3(d) The Contractor shall not be required to comply with this Article 5.4.3 with respect to a diesel-powered Nonroad Vehicle under the following circumstances:

5.4.3(d)(i) Where the City Agency makes a written finding, which is approved, in writing, by the DEP Commissioner, that the best available technology for reducing the emission of pollutants as required by this Article 5.4.3 is unavailable for such vehicle, the Contractor shall use whatever technology for reducing the emission of pollutants, if any, is available and appropriate for such vehicle.

5.4.3(d)(ii) Where the DEP Commissioner has issued a written waiver based upon the Contractor having demonstrated to the DEP Commissioner that the use of the best available technology for reducing the emission of pollutants might endanger the operator of such vehicle or those working near such vehicle, due to engine malfunction, the Contractor shall use whatever technology for

reducing the emission of pollutants, if any, is available and appropriate for such vehicle, which would not endanger the operator of such vehicle or those working near such vehicle.

5.4.3(d)(iii) In determining which technology to use for the purposes of Articles 5.4.3(d)(i) and 5.4.3(d)(ii) above, the Contractor shall primarily consider the reduction in emissions of particulate matter and secondarily consider the reduction in emissions of nitrogen oxides associated with the use of such technology, which shall in no event result in an increase in the emissions of either such pollutant.

5.4.3(d)(iv) The Contractor shall submit requests for a finding or a waiver pursuant to this Article 5.4.3(d) in writing to the DEP Commissioner, with a copy to the ACCO of the City Agency letting this Contract. Any finding or waiver made or issued pursuant to Articles 5.4.3(d)(i) and 5.4.3(d)(ii) above shall expire after one hundred eighty (180) Days, at which time the requirements of Article 5.4.3(a) shall be in full force and effect unless the City Agency renews the finding, in writing, and the DEP Commissioner approves such finding, in writing, or the DEP Commissioner renews the waiver, in writing.

5.4.3(e) The requirements of this Article 5.4.3 do not apply where they are precluded by federal or State funding requirements or where the Contract is an emergency procurement.

5.4.4 Section 24-163 of the Administrative Code. The Contractor shall comply with Section 24-163 of the Administrative Code related to the idling of the engines of motor vehicles while parking.

5.4.5 Compliance

5.4.5(a) The Contractor's compliance with Article 5.4 may be independently monitored. If it is determined that the Contractor has failed to comply with any provision of Article 5.4, any costs associated with any independent monitoring incurred by the City shall be reimbursed by the Contractor.

5.4.5(b) Any Contractor who violates any provision of Article 5.4, except as provided in Article 5.4.5(c) below, shall be liable for a civil penalty between the amounts of one thousand (\$1,000) and ten thousand (\$10,000) dollars, in addition to twice the amount of money saved by such Contractor for failure to comply with Article 5.4.

5.4.5(c) No Contractor shall make a false claim with respect to the provisions of Article 5.4 to a City Agency. Where a Contractor has been found to have done so, such Contractor shall be liable for a civil penalty of twenty thousand (\$20,000) dollars, in addition to twice the amount of money saved by such Contractor in association with having made such false claim.

5.4.6 Reporting

5.4.6(a) For all Public Works Contracts covered by this Article 5.4, the Contractor shall report to the City Agency the following information:

5.4.6(a)(i) The total number of diesel-powered Nonroad Vehicles used to fulfill the requirements of this Public Works Contract;

5.4.6(a)(ii) The number of such Nonroad Vehicles that were powered by Ultra Low Sulfur Diesel Fuel;

5.4.6(a)(iii) The number of such Nonroad Vehicles that utilized the best available technology for reducing the emission of pollutants, including a breakdown by vehicle model and the type of technology;

5.4.6(a)(iv) The number of such Nonroad Vehicles that utilized such other authorized technology in accordance with Article 5.4.3, including a breakdown by vehicle model and the type of technology used for each such vehicle;

5.4.6(a)(v) The locations where such Nonroad Vehicles were used; and

5.4.6(a)(vi) Where a determination is in effect pursuant to Article 5.4.2(b) or 5.4.2(c); detailed information concerning the Contractor's efforts to obtain Ultra Low Sulfur Diesel Fuel or diesel fuel that has a sulfur content of no more than thirty parts per million (30 ppm).

5.4.6(b) The Contractor shall submit the information required by Article 5.4.6(a) at the completion of Work under the Public Works Contract and on a yearly basis no later than August 1 throughout the term of the Public Works Contract. The yearly report shall cover Work performed during the preceding fiscal year (July 1 - June 30).

5.5 Ultra Low Sulfur Diesel Fuel. In accordance with the Coordinated Construction Act for Lower Manhattan, as amended:

5.5.1 Definitions. For purposes of this Article 5.5, the following definitions apply:

5.5.1(a) "Lower Manhattan" means the area to the south of and within the following lines: a line beginning at a point where the United States pierhead line in the Hudson River as it exists now or may be extended would intersect with the southerly line of West Houston Street in the Borough of Manhattan extended, thence easterly along the southerly side of West Houston Street to the southerly side of Houston Street, thence easterly along the southerly side of Houston Street to the southerly side of East Houston Street, thence northeasterly along the southerly side of East Houston Street to the point where it would intersect with the United States pierhead line in the East River as it exists now or may be extended, including tax lots within or immediately adjacent thereto.

5.5.1(b) "Lower Manhattan Redevelopment Project" means any project in Lower Manhattan that is funded in whole or in part with federal or State funding; or any project intended to improve transportation between Lower Manhattan and the two air terminals in the City known as LaGuardia Airport and John F. Kennedy International Airport, or between Lower Manhattan and the air terminal in Newark known as Newark Liberty International Airport, and that is funded in whole or in part with federal funding.

5.5.1(c) "Nonroad Engine" means an internal combustion engine (including the fuel system) that is not used in a Motor Vehicle or a vehicle used solely for competition, or that is not subject to standards promulgated under Section 7411 or Section 7521 of Title 42 of the United States Code, except that this term shall apply to internal combustion engines used to power generators, compressors or similar equipment used in any construction program or project.

5.5.1(d) "Nonroad Vehicle" means a vehicle that is powered by a Nonroad Engine, fifty (50) horsepower (HP) and greater, and that is not a Motor Vehicle or a vehicle used solely for competition, which shall include, but not be limited to, excavators, backhoes, cranes, compressors, generators, bulldozers, and similar equipment, except that this terms shall not apply to horticultural maintenance vehicles used for landscaping purposes that are powered by a Nonroad Engine of sixty-five (65) HP or less and that are not used in any construction program or project.

5.5.1(e) "Ultra Low Sulfur Diesel Fuel" means diesel fuel that has a sulfur content of no more than fifteen parts per million (15 ppm).

5.5.2 Requirements. Contractors and Subcontractors are required to use only Ultra Low Sulfur Diesel Fuel to power the diesel-powered Nonroad Vehicles with engine HP rating of fifty (50) HP and above used on a Lower Manhattan Redevelopment Project and, where practicable, to reduce the emission of pollutants by retrofitting such Nonroad Vehicles with oxidation catalysts, particulate filters, or technology that achieves lowest particulate matter emissions.

5.6 Pesticides. In accordance with Section 17-1209 of the Administrative Code, to the extent that the Contractor or any Subcontractor applies pesticides to any property owned or leased by the City, the Contractor, and any Subcontractor shall comply with Chapter 12 of the Administrative Code.

5.7 Waste Treatment, Storage, and Disposal Facilities and Transporters. In connection with the Work, the Contractor and any Subcontractor shall use only those waste treatment, storage, and disposal facilities and waste transporters that possess the requisite license, permit or other governmental approval necessary to treat, store, dispose, or transport the waste, materials or hazardous substances.

5.8 Environmentally Preferable Purchasing. The Contractor shall ensure that products purchased or leased by the Contractor or any Subcontractor for the Work that are not specified by the City or are submitted as equivalents to a product specified by the City comply with the requirements of the New York City Environmentally Preferable Purchasing Program contained in Chapter 11 of Title 43 of the RCNY, pursuant to Chapter 3 of Title 6 of the Administrative Code.

ARTICLE 6. INSPECTION

6.1 During the progress of the Work and up to the date of Final Acceptance, the Contractor shall at all times afford the representatives of the City every reasonable, safe, and proper facility for inspecting all Work done or being done at the Site and also for inspecting the manufacture or preparation of materials and equipment at the place of such manufacture or preparation.

6.2 The Contractor's obligation hereunder shall include the uncovering or taking down of finished Work and its restoration thereafter; provided, however, that the order to uncover, take down and restore shall be in writing, and further provided that if Work thus exposed proves satisfactory, and if the Contractor has complied with Article 6.1, such uncovering or taking down and restoration shall be

considered an item of Extra Work to be paid for in accordance with the provisions of Article 26. If the Work thus exposed proves unsatisfactory, the City has no obligation to compensate the Contractor for the uncovering, taking down or restoration.

6.3 Inspection and approval by the Commissioner, the Engineer, Project Manager, or Resident Engineer, of finished Work or of Work being performed, or of materials and equipment at the place of manufacture or preparation, shall not relieve the Contractor of its obligation to perform the Work in strict accordance with the Contract. Finished or unfinished Work not found to be in strict accordance with the Contract shall be replaced as directed by the Engineer, even though such Work may have been previously approved and paid for. Such corrective Work is Contract Work and shall not be deemed Extra Work.

6.4 Rejected Work and materials shall be promptly taken down and removed from the Site, which must at all times be kept in a reasonably clean and neat condition.

ARTICLE 7. PROTECTION OF WORK AND OF PERSONS AND PROPERTY; NOTICES AND INDEMNIFICATION

7.1 During the performance of the Work and up to the date of Final Acceptance, the Contractor shall be under an absolute obligation to protect the finished and unfinished Work against any damage, loss, injury, theft and/or vandalism and in the event of such damage, loss, injury, theft and/or vandalism, it shall promptly replace and/or repair such Work at the Contractor's sole cost and expense, as directed by the Resident Engineer. The obligation to deliver finished Work in strict accordance with the Contract prior to Final Acceptance shall be absolute and shall not be affected by the Resident Engineer's approval of, or failure to prohibit, the Means and Methods of Construction used by the Contractor.

7.2 During the performance of the Work and up to the date of Final Acceptance, the Contractor shall take all reasonable precautions to protect all persons and the property of the City and of others from damage, loss or injury resulting from the Contractor's, and/or its Subcontractors' operations under this Contract. The Contractor's obligation to protect shall include the duty to provide, place or replace, and adequately maintain at or about the Site suitable and sufficient protection such as lights, barricades, and enclosures.

7.3 The Contractor shall comply with the notification requirements set forth below in the event of any loss, damage or injury to Work, persons or property, or any accidents arising out of the operations of the Contractor and/or its Subcontractors under this Contract.

7.3.1 The Contractor shall make a full and complete report in writing to the Resident Engineer within three (3) Days after the occurrence.

7.3.2 The Contractor shall also send written notice of any such event to all insurance carriers that issued potentially responsive policies (including commercial general liability insurance carriers for events relating to the Contractor's own employees) no later than twenty (20) days after such event and again no later than twenty (20) days after the initiation of any claim and/or action resulting therefrom. Such notice shall contain the following information: the number of the insurance policy, the name of the Named Insured, the date and location of the incident, and the identity of the persons injured or property damaged. For any policy on which the City and/or the Engineer, Architect, or Project Manager are Additional Insureds, such notice shall expressly specify that "this notice is

being given on behalf of the City of New York as Additional Insured, such other Additional Insureds, as well as the Named Insured."

7.3.2(a) Whenever such notice is sent under a policy on which the City is an Additional Insured, the Contractor shall provide copies of the notice to the Comptroller, the Commissioner and the City Corporation Counsel. The copy to the Comptroller shall be sent to the Insurance Unit, NYC Comptroller's Office, 1 Centre Street - Room 1222, New York, New York, 10007. The copy to the Commissioner shall be sent to the address set forth in Schedule A of the General Conditions. The copy to the City Corporation Counsel shall be sent to Insurance Claims Specialist, Affirmative Litigation Division, New York City Law Department, 100 Church Street, New York, New York 10007.

7.3.2(b) If the Contractor fails to provide any of the foregoing notices to any appropriate insurance carrier(s) in a timely and complete manner, the Contractor shall indemnify the City for all losses, judgments, settlements, and expenses, including reasonable attorneys' fees, arising from an insurer's disclaimer of coverage citing late notice by or on behalf of the City.

7.4 To the fullest extent permitted by law, the Contractor shall defend, indemnify, and hold the City, its employees, and officials (the "Indemnitees") harmless against any and all claims (including but not limited to claims asserted by any employee of the Contractor and/or its Subcontractors) and costs and expenses of whatever kind (including but not limited to payment or reimbursement of attorneys' fees and disbursements) allegedly arising out of or in any way related to the operations of the Contractor and/or its Subcontractors in the performance of this Contract or from the Contractor's and/or its Subcontractors' failure to comply with any of the provisions of this Contract or of the Law. Such costs and expenses shall include all those incurred in defending the underlying claim and those incurred in connection with the enforcement of this Article 7.4 by way of cross-claim, third-party claim, declaratory action or otherwise. The parties expressly agree that the indemnification obligation hereunder contemplates (1) full indemnity in the event of liability imposed against the Indemnitees without negligence and solely by reason of statute, operation of Law or otherwise; and (2) partial indemnity in the event of any actual negligence on the part of the Indemnitees either causing or contributing to the underlying claim (in which case, indemnification will be limited to any liability imposed over and above that percentage attributable to actual fault whether by statute, by operation of Law, or otherwise). Where partial indemnity is provided hereunder, all costs and expenses shall be indemnified on a pro rata basis.

7.4.1 Indemnification under Article 7.4 or any other provision of the Contract shall operate whether or not Contractor or its Subcontractors have placed and maintained the insurance specified under Article 22.

7.5 The provisions of this Article 7 shall not be deemed to create any new right of action in favor of third parties against the Contractor or the City.

CHAPTER III: TIME PROVISIONS

ARTICLE 8. COMMENCEMENT AND PROSECUTION OF THE WORK

8.1 The Contractor shall commence the Work on the date specified in the Notice to Proceed or the Order to Work. The time for performance of the Work under the Contract shall be computed from

the date specified in the Notice to Proceed or the Order to Work. **TIME BEING OF THE ESSENCE** to the City, the Contractor shall thereafter prosecute the Work diligently, using such Means and Methods of Construction as are in accord with Article 4 herein and as will assure its completion not later than the date specified in this Contract, or on the date to which the time for completion may be extended.

ARTICLE 9. PROGRESS SCHEDULES

9.1 To enable the Work to be performed in an orderly and expeditious manner, the Contractor, within fifteen (15) Days after the Notice to Proceed or Order to Work, unless otherwise directed by the Engineer, shall submit to the Engineer a proposed progress schedule based on the Critical Path Method in the form of a bar graph or in such other form as specified by the Engineer, and monthly cash flow requirements, showing:

9.1.1 The anticipated time of commencement and completion of each of the various operations to be performed under this Contract; and

9.1.2 The sequence and interrelation of each of these operations with the others and with those of other related contracts; and

9.1.3 The estimated time required for fabrication or delivery, or both, of all materials and equipment required for the Work, including the anticipated time for obtaining required approvals pursuant to Article 10; and

9.1.4 The estimated amount in dollars the Contractor will claim on a monthly basis.

9.2 The proposed schedule shall be revised as directed by the Engineer, until finally approved by the Engineer, and after such approval, subject to the provisions of Article 11, shall be strictly adhered to by the Contractor.

9.3 If the Contractor shall fail to adhere to the approved progress schedule, or to the schedule as revised pursuant to Article 11, it shall promptly adopt such other or additional Means and Methods of Construction, at its sole cost and expense, as will make up for the time lost and will assure completion in accordance with the approved progress schedule. The approval by the City of a progress schedule which is shorter than the time allotted under the Contract shall not create any liability for the City if the approved progress schedule is not met.

9.4 The Contractor will not receive any payments until the proposed progress schedule is submitted.

ARTICLE 10. REQUESTS FOR INFORMATION OR APPROVAL

10.1 From time to time as the Work progresses and in the sequence indicated by the approved progress schedule, the Contractor shall submit to the Engineer a specific request in writing for each item of information or approval required by the Contractor. These requests shall state the latest date upon which the information or approval is actually required by the Contractor, and shall be submitted in a reasonable time in advance thereof to provide the Engineer a sufficient time to act upon such submissions, or any necessary re-submissions thereof.

10.2 The Contractor shall not have any right to an extension of time on account of delays due to the Contractor's failure to submit requests for the required information or the required approval in accordance with the above requirements.

ARTICLE 11. NOTICE OF CONDITIONS CAUSING DELAY AND DOCUMENTATION OF DAMAGES CAUSED BY DELAY

11.1 After the commencement of any condition which is causing or may cause a delay in completion of the Work, including conditions for which the Contractor may be entitled to an extension of time, the following notifications and submittals are required:

11.1.1 Within fifteen (15) Days after the Contractor becomes aware or reasonably should be aware of each such condition, the Contractor must notify the Resident Engineer or Engineer, as directed by the Commissioner, in writing of the existence, nature and effect of such condition upon the approved progress schedule and the Work, and must state why and in what respects, if any, the condition is causing or may cause a delay. Such notice shall include a description of the construction activities that are or could be affected by the condition and may include any recommendations the Contractor may have to address the delay condition and any activities the Contractor may take to avoid or minimize the delay.

11.1.2 If the Contractor shall claim to be sustaining damages for delay as provided for in this Article 11, within forty-five (45) Days from the time such damages are first incurred for each such condition, the Contractor shall submit to the Commissioner a verified written statement of the details and estimates of the amounts of such damages, including categories of expected damages and projected monthly costs, together with documentary evidence of such damages as the Contractor may have at the time of submission ("statement of delay damages"), as further detailed in Article 11.6. The Contractor may submit the above statement within such additional time as may be granted by the Commissioner in writing upon written request therefor.

11.1.3 Articles 11.1.1 and 11.1.2 do not relieve the Contractor of its obligation to comply with the provisions of Article 44.

11.2 Failure of the Contractor to strictly comply with the requirements of Article 11.1.1 may, in the discretion of the Commissioner, be deemed sufficient cause to deny any extension of time on account of delay arising out of such condition. Failure of the Contractor to strictly comply with the requirements of both Articles 11.1.1 and 11.1.2 shall be deemed a conclusive waiver by the Contractor of any and all claims for damages for delay arising from such condition and no right to recover on such claims shall exist.

11.3 When appropriate and directed by the Engineer, the progress schedule shall be revised by the Contractor until finally approved by the Engineer. The revised progress schedule must be strictly adhered to by the Contractor.

11.4 Compensable Delays

11.4.1 The Contractor agrees to make claim only for additional costs attributable to delay in the performance of this Contract necessarily extending the time for completion of the Work or resulting from acceleration directed by the Commissioner and required to maintain the progress schedule, occasioned solely by any act or omission to act of the City listed below. The Contractor also agrees that delay from any other cause shall be

compensated, if at all, solely by an extension of time to complete the performance of the Work.

11.4.1.1 The failure of the City to take reasonable measures to coordinate and progress the Work to the extent required by the Contract, except that the City shall not be responsible for the Contractor's obligation to coordinate and progress the Work of its Subcontractors.

11.4.1.2 Unreasonable delays attributable to the review of shop drawings, the issuance of change orders, or the cumulative impact of change orders that were not brought about by any act or omission of the Contractor.

11.4.1.3 The unavailability of the Site caused by acts or omissions of the City.

11.4.1.4 The issuance by the Engineer of a stop work order that was not brought about through any act or omission of the Contractor.

11.4.1.5 Differing site conditions or environmental hazards that were neither known nor reasonably ascertainable on a pre-bid inspection of the Site or review of the bid documents or other publicly available sources, and that are not ordinarily encountered in the Project's geographical area or neighborhood or in the type of Work to be performed.

11.4.1.6 Delays caused by the City's bad faith or its willful, malicious, or grossly negligent conduct.

11.4.1.7 Delays not contemplated by the parties;

11.4.1.8 Delays so unreasonable that they constitute an intentional abandonment of the Contract by the City; and

11.4.1.9 Delays resulting from the City's breach of a fundamental obligation of the Contract.

11.4.2 No claim may be made for any alleged delay in Substantial Completion of the Work if the Work will be or is substantially completed by the date of Substantial Completion provided for in Schedule A unless acceleration has been directed by the Commissioner to meet the date of Substantial Completion set forth in Schedule A, or unless there is a provision in the Contract providing for additional compensation for early completion.

11.4.3 The provisions of this Article 11 apply only to claims for additional costs attributable to delay and do not preclude determinations by the Commissioner allowing reimbursements for additional costs for Extra Work pursuant to Articles 25 and 26 of this Contract. To the extent that any cost attributable to delay is reimbursed as part of a change order, no additional claim for compensation under this Article 11 shall be allowed.

11.5 Non-Compensable Delays. The Contractor agrees to make no claim for, and is deemed to have included in its bid prices for the various items of the Contract, the extra/additional costs attributable to any delays caused by or attributable to the items set forth below. For such items, the Contractor shall be compensated, if at all, solely by an extension of time to complete the performance of the Work, in accordance with the provisions of Article 13. Such extensions of time will be granted, if at all, pursuant to the grounds set forth in Article 13.3.

11.5.1 The acts or omissions of any third parties, including but not limited to Other Contractors, public/ governmental bodies (other than City Agencies), utilities or private enterprises, who are disclosed in the Contract Documents or are ordinarily encountered or generally recognized as related to the Work;

11.5.2 Any situation which was within the contemplation of the parties at the time of entering into the Contract, including any delay indicated or disclosed in the Contract Documents or that would be generally recognized by a reasonably prudent contractor as related to the nature of the Work, and/or the existence of any facility or appurtenance owned, operated or maintained by any third party, as indicated or disclosed in the Contract Documents or ordinarily encountered or generally recognized as related to the nature of the Work;

11.5.3 Restraining orders, injunctions or judgments issued by a court which were caused by a Contractor's submission, action or inaction or by a Contractor's Means and Methods of Construction, or by third parties, unless such order, injunction or judgment was the result of an act or omission by the City;

11.5.4 Any labor boycott, strike, picketing, lockout or similar situation;

11.5.5 Any shortages of supplies or materials, or unavailability of equipment, required by the Contract Work;

11.5.6 Climatic conditions, storms, floods, droughts, tidal waves, fires, hurricanes, earthquakes, landslides or other catastrophes or acts of God, or acts of war or of the public enemy or terrorist acts, including the City's reasonable responses thereto; and

11.5.7 Extra Work which does not significantly affect the overall completion of the Contract, reasonable delays in the review or issuance of change orders or field orders and/or in shop drawing reviews or approvals.

11.6 Required Content of Submission of Statement of Delay Damages

11.6.1 In the verified written statement of delay damages required by Article 11.1.2, the following information shall be provided by the Contractor:

11.6.1.1 For each delay, the start and end dates of the claimed periods of delay and, in addition, a description of the operations that were delayed, an explanation of how they were delayed, and the reasons for the delay, including identifying the applicable act or omission of the City listed in Article 11.4.

11.6.1.2 A detailed factual statement of the claim providing all necessary dates, locations and items of Work affected by the claim.

11.6.1.3 The estimated amount of additional compensation sought and a breakdown of that amount into categories as described in Article 11.7.

11.6.1.4 Any additional information requested by the Commissioner.

11.7 Recoverable Costs

11.7.1 Delay damages may be recoverable for the following costs actually and necessarily incurred in the performance of the Work:

11.7.1.1 Direct labor, including payroll taxes (subject to statutory wage caps) and supplemental benefits, based on time and materials records;

11.7.1.2 Necessary materials (including transportation to the Site), based on time and material records;

- 11.7.1.3 Reasonable rental value of necessary plant and equipment other than small tools; plus fuel/energy costs according to the applicable formula set forth in Articles 26.2.4 and/or 26.2.8, based on time and material records;
- 11.7.1.4 Additional insurance and bond costs;
- 11.7.1.5 Extended Site overhead; field office rental, salaries of field office staff, on-site project managers and superintendents; field office staff vehicles, Project-specific storage, field office utilities and telephone, and field office consumables;
- 11.7.1.6 Labor escalation costs based on actual costs;
- 11.7.1.7 Materials and equipment escalation costs based on applicable industry indices unless documentation of actual increased cost is provided;
- 11.7.1.8 Additional material and equipment storage costs based on actual documented costs and additional costs necessitated by extended manufacturer warranty periods; and
- 11.7.1.9 Extended home office overhead calculated based on the following formula:
 - (1) Subtract from the original Contract amount the amount earned by original contractual Substantial Completion date (not including change orders);
 - (2) Remove 15% overhead and profit from the calculation in item (1) by dividing the results of item (1) by 1.15;
 - (3) Multiply the result of item (2) by 7.25% for the total home office overhead;
 - (4) Multiply the result of item (3) by 7.25% for the total profit; and
 - (5) The total extended home office overhead will be the total of items (3) and (4).

11.7.2 Recoverable Subcontractor Costs. When the Work is performed by a Subcontractor, the Contractor may be paid the actual and necessary costs of such subcontracted Work as outlined above in Articles 11.7.1.1 through 11.7.1.8, and an additional overhead of 5% of the costs outlined in Articles 11.7.1.1 through 11.7.1.3.

11.7.3 Non-Recoverable Costs. The parties agree that the City will have no liability for the following items and the Contractor agrees it shall make no claim for the following items:

- 11.7.3.1 Profit, or loss of anticipated or unanticipated profit, except as provided in Article 11.7.1.9;
- 11.7.3.2 Consequential damages, including, but not limited to, construction or bridge loans or interest paid on such loans, loss of bonding capacity, bidding opportunities, or interest in investment, or any resulting insolvency;
- 11.7.3.3 Indirect costs or expenses of any nature except those included in Article 11.7.1;
- 11.7.3.4 Direct or indirect costs attributable to performance of Work where the Contractor, because of situations or conditions within its control, has not progressed the Work in a satisfactory manner; and
- 11.7.3.5 Attorneys' fees and dispute and claims preparation expenses.

- 11.8 Any claims for delay under this Article 11 are not subject to the jurisdiction of the Contract Dispute Resolution Board pursuant to the dispute resolution process set forth in Article 27.
- 11.9 Any compensation provided to the Contractor in accordance with this Article 11 will be made pursuant to a claim filed with the Comptroller. Nothing in this Article 11 extends the time for the Contractor to file an action with respect to a claim within six months after Substantial Completion pursuant to Article 56.

ARTICLE 12. COORDINATION WITH OTHER CONTRACTORS

12.1 During the progress of the Work, Other Contractors may be engaged in performing other work or may be awarded other contracts for additional work on this Project. In that event, the Contractor shall coordinate the Work to be done hereunder with the work of such Other Contractors and the Contractor shall fully cooperate with such Other Contractors and carefully fit its own Work to that provided under other contracts as may be directed by the Engineer. The Contractor shall not commit or permit any act which will interfere with the performance of work by any Other Contractors.

12.2 If the Engineer determines that the Contractor is failing to coordinate its Work with the work of Other Contractors as the Engineer has directed, then the Commissioner shall have the right to withhold any payments otherwise due hereunder until the Contractor completely complies with the Engineer's directions.

12.3 The Contractor shall notify the Engineer in writing if any Other Contractor on this Project is failing to coordinate its work with the Work of this Contract. If the Engineer finds such charges to be true, the Engineer shall promptly issue such directions to the Other Contractor with respect thereto as the situation may require. The City shall not, however, be liable for any damages suffered by any Other Contractor's failure to coordinate its work with the Work of this Contract or by reason of the Other Contractor's failure to promptly comply with the directions so issued by the Engineer, or by reason of any Other Contractor's default in performance, it being understood that the City does not guarantee the responsibility or continued efficiency of any contractor. The Contractor agrees to make no claim against the City for any damages relating to or arising out of any directions issued by the Engineer pursuant to this Article 12 (including but not limited to the failure of any Other Contractor to comply or promptly comply with such directions), or the failure of any Other Contractor to coordinate its work, or the default in performance of any Other Contractor.

12.4 The Contractor shall indemnify and hold the City harmless from any and all claims or judgments for damages and from costs and expenses to which the City may be subjected or which it may suffer or incur by reason of the Contractor's failure to comply with the Engineer's directions promptly; and the Comptroller shall have the right to exercise the powers reserved in Article 23 with respect to any claims which may be made for damages due to the Contractor's failure to comply with the Engineer's directions promptly. Insofar as the facts and Law relating to any claim would preclude the City from being completely indemnified by the Contractor, the City shall be partially indemnified by the Contractor to the fullest extent provided by Law.

12.5 Should the Contractor sustain any damage through any act or omission of any Other Contractor having a contract with the City for the performance of work upon the Site or of work which may be necessary to be performed for the proper prosecution of the Work to be performed hereunder, or through any act or omission of a subcontractor of such Other Contractor, the Contractor shall have no claim against the City for such damage, but shall have a right to recover such damage from the Other

Contractor under the provision similar to the following provisions which apply to this Contract and have been or will be inserted in the contracts with such Other Contractors:

12.5.1 Should any Other Contractor having or who shall hereafter have a contract with the City for the performance of work upon the Site sustain any damage through any act or omission of the Contractor hereunder or through any act or omission of any Subcontractor of the Contractor, the Contractor agrees to reimburse such Other Contractor for all such damages and to defend at its own expense any action based upon such claim and if any judgment or claim (even if the allegations of the action are without merit) against the City shall be allowed the Contractor shall pay or satisfy such judgment or claim and pay all costs and expenses in connection therewith and agrees to indemnify and hold the City harmless from all such claims. Insofar as the facts and Law relating to any claim would preclude the City from being completely indemnified by the Contractor, the City shall be partially indemnified by the Contractor to the fullest extent provided by Law.

12.6 The City's right to indemnification hereunder shall in no way be diminished, waived or discharged by its recourse to assessment of liquidated damages as provided in Article 15, or by the exercise of any other remedy provided for by Contract or by Law.

ARTICLE 13. EXTENSION OF TIME FOR PERFORMANCE

13.1 If performance by the Contractor is delayed for a reason set forth in Article 13.3, the Contractor may be allowed a reasonable extension of time in conformance with this Article 13 and the PPB Rules.

13.2 Any extension of time may be granted only by the ACCO or by the Board for the Extension of Time (hereafter "Board") (as set forth below) upon written application by the Contractor.

13.3 Grounds for Extension: If such application is made, the Contractor shall be entitled to an extension of time for delay in completion of the Work caused solely:

13.3.1 By the acts or omissions of the City, its officials, agents or employees; or

13.3.2 By the act or omissions of Other Contractors on this Project; or

13.3.3 By supervening conditions entirely beyond the control of either party hereto (such as, but not limited to, acts of God or the public enemy, excessive inclement weather, war or other national emergency making performance temporarily impossible or illegal, or strikes or labor disputes not brought about by any act or omission of the Contractor).

13.3.4 The Contractor shall, however, be entitled to an extension of time for such causes only for the number of Days of delay which the ACCO or the Board may determine to be due solely to such causes, and then only if the Contractor shall have strictly complied with all of the requirements of Articles 9 and 10.

13.4 The Contractor shall not be entitled to receive a separate extension of time for each of several causes of delay operating concurrently; but, if at all, only for the actual period of delay in completion of the Work as determined by the ACCO or the Board, irrespective of the number of causes contributing to produce such delay. If one of several causes of delay operating concurrently results from any act, fault or omission of the Contractor or of its Subcontractors or Materialmen, and would of itself (irrespective

of the concurrent causes) have delayed the Work, no extension of time will be allowed for the period of delay resulting from such act, fault or omission.

13.5 The determination made by the ACCO or the Board on an application for an extension of time shall be binding and conclusive on the Contractor.

13.6 The ACCO or the Board acting entirely within their discretion may grant an application for an extension of time for causes of delay other than those herein referred.

13.7 Permitting the Contractor to continue with the Work after the time fixed for its completion has expired, or after the time to which such completion may have been extended has expired, or the making of any payment to the Contractor after such time, shall in no way operate as a waiver on the part of the City of any of its rights under this Contract.

13.8 Application for Extension of Time:

13.8.1 Before the Contractor's time extension request will be considered, the Contractor shall notify the ACCO of the condition which allegedly has caused or is causing the delay, and shall submit a written application to the ACCO identifying:

13.8.1(a) The Contractor; the registration number; and Project description;

13.8.1(b) Liquidated damage assessment rate, as specified in the Contract;

13.8.1(c) Original total bid price;

13.8.1(d) The original Contract start date and completion date;

13.8.1(e) Any previous time extensions granted (number and duration); and

13.8.1(f) The extension of time requested.

13.8.2 In addition, the application for extension of time shall set forth in detail:

13.8.2(a) The nature of each alleged cause of delay in completing the Work;

13.8.2(b) The date upon which each such cause of delay began and ended and the number of Days attributable to each such cause;

13.8.2(c) A statement that the Contractor waives all claims except for those delineated in the application, and the particulars of any claims which the Contractor does not agree to waive. For time extensions for Substantial Completion and final completion payments, the application shall include a detailed statement of the dollar amounts of each element of claim item reserved; and

13.8.2(d) A statement indicating the Contractor's understanding that the time extension is granted only for purposes of permitting continuation of Contract performance and payment for Work performed and that the City retains its right to conduct an investigation and assess liquidated damages as appropriate in the future.

13.9 Analysis and Approval of Time Extensions:

13.9.1 For time extensions for partial payments, a written determination shall be made by the ACCO who may, for good and sufficient cause, extend the time for the performance of the Contract as follows:

13.9.1(a) If the Work is to be completed within six (6) months, the time for performance may be extended for sixty (60) Days;

13.9.1(b) If the Work is to be completed within less than one (1) year but more than six (6) months, an extension of ninety (90) Days may be granted;

13.9.1(c) If the Contract period exceeds one (1) year, besides the extension granted in Article 13.9.1(b), an additional thirty (30) Days may be granted for each multiple of six (6) months involved beyond the one (1) year period; or

13.9.1(d) If exceptional circumstances exist, the ACCO may extend the time for performance beyond the extensions in Articles 13.9.1(a), 13.9.1(b), and 13.9.1(c). In that event, the ACCO shall file with the Mayor's Office of Contract Services a written explanation of the exceptional circumstances.

13.9.2 For extensions of time for Substantial Completion and final completion payments, the Engineer, in consultation with the ACCO, shall prepare a written analysis of the delay (including a preliminary determination of the causes of delay, the beginning and end dates for each such cause of delay, and whether the delays are excusable under the terms of this Contract). The report shall be subject to review by and approval of the Board, which shall have authority to question its analysis and determinations and request additional facts or documentation. The report as reviewed and made final by the Board shall be made a part of the Agency contract file. Neither the report itself nor anything contained therein shall operate as a waiver or release of any claim the City may have against the Contractor for either actual or liquidated damages.

13.9.3 Approval Mechanism for Time Extensions for Substantial Completion or Final Completion Payments: An extension shall be granted only with the approval of the Board which is comprised of the ACCO of the Agency, the City Corporation Counsel, and the Comptroller, or their authorized representatives.

13.9.4 Neither the granting of any application for an extension of time to the Contractor or any Other Contractor on this Project nor the papers, records or reports related to any application for or grant of an extension of time or determination related thereto shall be referred to or offered in evidence by the Contractor or its attorneys in any action or proceeding.

13.10 No Damage for Delay: The Contractor agrees to make no claim for damages for delay in the performance of this Contract occasioned by any act or omission to act of the City or any of its representatives, except as provided for in Article 11.

ARTICLE 14. COMPLETION AND FINAL ACCEPTANCE OF THE WORK

14.1 Date for Substantial Completion: The Contractor shall substantially complete the Work within the time fixed in Schedule A of the General Conditions, or within the time to which such Substantial Completion may be extended.

14.2 Determining the Date of Substantial Completion: The Work will be deemed to be substantially complete when the two conditions set forth below have been met.

14.2.1 Inspection: The Engineer or Resident Engineer, as applicable, has inspected the Work and has made a written determination that it is substantially complete.

14.2.2 Approval of Final Approved Punch List and Date for Final Acceptance: Following inspection of the Work, the Engineer/Resident Engineer shall furnish the Contractor with a final punch list, specifying all items of Work to be completed and proposing dates for the completion of each specified item of Work. The Contractor shall then submit in writing to the Engineer/Resident Engineer within ten (10) Days of the Engineer/Resident Engineer furnishing the final punch list either acceptance of the dates or proposed alternative dates for the completion of each specified item of Work. If the Contractor neither accepts the dates nor proposes alternative dates within ten (10) Days, the schedule proposed by the Engineer/Resident Engineer shall be deemed accepted. If the Contractor proposes alternative dates, then, within a reasonable time after receipt, the Engineer/Resident Engineer, in a written notification to the Contractor, shall approve the Contractor's completion dates or, if they are unable to agree, the Engineer/Resident Engineer shall establish dates for the completion of each item of Work. The latest completion date specified shall be the date for Final Acceptance of the Work.

14.3 Date of Substantial Completion. The date of approval of the Final Approved Punch List, shall be the date of Substantial Completion. The date of approval of the Final Approved Punch List shall be either (a) if the Contractor approves the final punch list and proposed dates for completion furnished by the Engineer/Resident Engineer, the date of the Contractor's approval; or (b) if the Contractor neither accepts the dates nor proposes alternative dates, ten (10) Days after the Engineer/Resident Engineer furnishes the Contractor with a final punch list and proposed dates for completion; or (c) if the Contractor proposes alternative dates, the date that the Engineer/Resident Engineer sends written notification to the Contractor either approving the Contractor's proposed alternative dates or establishing dates for the completion for each item of Work.

14.4 Determining the Date of Final Acceptance: The Work will be accepted as final and complete as of the date of the Engineer's/Resident Engineer's inspection if, upon such inspection, the Engineer/Resident Engineer finds that all items on the Final Approved Punch List are complete and no further Work remains to be done. The Commissioner will then issue a written determination of Final Acceptance.

14.5 Request for Inspection: Inspection of the Work by the Engineer/Resident Engineer for the purpose of Substantial Completion or Final Acceptance shall be made within fourteen (14) Days after receipt of the Contractor's written request therefor.

14.6 Request for Re-inspection: If upon inspection for the purpose of Substantial Completion or Final Acceptance, the Engineer/Resident Engineer determines that there are items of Work still to be performed, the Contractor shall promptly perform them and then request a re-inspection. If upon re-inspection, the Engineer/Resident Engineer determines that the Work is substantially complete or finally accepted, the date of such re-inspection shall be the date of Substantial Completion or Final Acceptance. Re-inspection by the Engineer/Resident Engineer shall be made within ten (10) Days after receipt of the Contractor's written request therefor.

14.7 Initiation of Inspection by the Engineer/Resident Engineer: If the Contractor does not request inspection or re-inspection of the Work for the purpose of Substantial Completion or Final Acceptance, the Engineer/Resident Engineer may initiate such inspection or re-inspection.

ARTICLE 15. LIQUIDATED DAMAGES

15.1 In the event the Contractor fails to substantially complete the Work within the time fixed for such Substantial Completion in Schedule A of the General Conditions, plus authorized time extensions, or if the Contractor, in the sole determination of the Commissioner, has abandoned the Work, the Contractor shall pay to the City the sum fixed in Schedule A of the General Conditions, for each and every Day that the time consumed in substantially completing the Work exceeds the time allowed therefor; which said sum, in view of the difficulty of accurately ascertaining the loss which the City will suffer by reason of delay in the Substantial Completion of the Work hereunder, is hereby fixed and agreed as the liquidated damages that the City will suffer by reason of such delay, and not as a penalty. This Article 15 shall also apply to the Contractor whether or not the Contractor is defaulted pursuant to Chapter X of this Contract. Neither the failure to assess liquidated damages nor the granting of any time extension shall operate as a waiver or release of any claim the City may have against the Contractor for either actual or liquidated damages.

15.2 Liquidated damages received hereunder are not intended to be nor shall they be treated as either a partial or full waiver or discharge of the City's right to indemnification, or the Contractor's obligation to indemnify the City, or to any other remedy provided for in this Contract or by Law.

15.3 The Commissioner may deduct and retain out of the monies which may become due hereunder, the amount of any such liquidated damages; and in case the amount which may become due hereunder shall be less than the amount of liquidated damages suffered by the City, the Contractor shall be liable to pay the difference.

ARTICLE 16. OCCUPATION OR USE PRIOR TO COMPLETION

16.1 Unless otherwise provided for in the Specifications, the Commissioner may take over, use, occupy or operate any part of the Work at any time prior to Final Acceptance, upon written notification to the Contractor. The Engineer or Resident Engineer, as applicable, shall inspect the part of the Work to be taken over, used, occupied, or operated, and will furnish the Contractor with a written statement of the Work, if any, which remains to be performed on such part. The Contractor shall not object to, nor interfere with, the Commissioner's decision to exercise the rights granted by Article 16. In the event the Commissioner takes over, uses, occupies, or operates any part of the Work:

16.1.1 the Engineer/Resident Engineer shall issue a written determination of Substantial Completion with respect to such part of the Work;

16.1.2 the Contractor shall be relieved of its absolute obligation to protect such part of the unfinished Work in accordance with Article 7;

16.1.3 the Contractor's guarantee on such part of the Work shall begin on the date of such use by the City; and;

16.1.4 the Contractor shall be entitled to a return of so much of the amount retained in accordance with Article 21 as it relates to such part of the Work, except so much thereof as may be retained under Articles 24 and 44.

CHAPTER IV: SUBCONTRACTS AND ASSIGNMENTS

ARTICLE 17. SUBCONTRACTS

17.1 The Contractor shall not make subcontracts totaling an amount more than the percentage of the total Contract price fixed in Schedule A of the General Conditions, without prior written permission from the Commissioner. All subcontracts made by the Contractor shall be in writing. No Work may be performed by a Subcontractor prior to the Contractor entering into a written subcontract with the Subcontractor and complying with the provisions of this Article 17.

17.2 Before making any subcontracts, the Contractor shall submit a written statement to the Commissioner giving the name and address of the proposed Subcontractor; the portion of the Work and materials which it is to perform and furnish; the cost of the subcontract; the VENDEX questionnaire if required; the proposed subcontract if requested by the Commissioner; and any other information tending to prove that the proposed Subcontractor has the necessary facilities, skill, integrity, past experience, and financial resources to perform the Work in accordance with the terms and conditions of this Contract.

17.3 In addition to the requirements in Article 17.2, Contractor is required to list the Subcontractor in the web based Subcontractor Reporting System through the City's Payee Information Portal (PIP), available at www.nyc.gov/pip.¹ For each Subcontractor listed, Contractor is required to provide the following information: maximum contract value, description of Subcontractor's Work, start and end date of the subcontract and identification of the Subcontractor's industry. Thereafter, Contractor will be required to report in the system the payments made to each Subcontractor within 30 days of making the payment. If any of the required information changes throughout the Term of the Contract, Contractor will be required to revise the information in the system.

Failure of the Contractor to list a Subcontractor and/or to report Subcontractor payments in a timely fashion may result in the Commissioner declaring the Contractor in default of the Contract and will subject Contractor to liquidated damages in the amount of \$100 per day for each day that the Contractor fails to identify a Subcontractor along with the required information about the Subcontractor and/or fails to report payments to a Subcontractor, beyond the time frames set forth herein or in the notice from the City. Article 15 shall govern the issue of liquidated damages.

17.4 If an approved Subcontractor elects to subcontract any portion of its subcontract, the proposed sub-subcontract shall be submitted in the same manner as directed above.

17.5 The Commissioner will notify the Contractor in writing whether the proposed Subcontractor is approved. If the proposed Subcontractor is not approved, the Contractor may submit another proposed Subcontractor unless the Contractor decides to do the Work. No Subcontractor shall be permitted to enter or perform any work on the Site unless approved.

17.6 Before entering into any subcontract hereunder, the Contractor shall provide the proposed Subcontractor with a complete copy of this document and inform the proposed Subcontractor fully and completely of all provisions and requirements of this Contract relating either directly or indirectly to the Work to be performed and the materials to be furnished under such subcontract, and every such

¹ In order to use the new system, a PIP account will be required. Detailed instructions on creating a PIP account and using the new system are also available at www.nyc.gov/pip. Additional assistance with PIP may be obtained by emailing the Financial Information Services Agency Help Desk at pip@fisa.nyc.gov.

Subcontractor shall expressly stipulate that all labor performed and materials furnished by the Subcontractor shall strictly comply with the requirements of this Contract.

17.7 Documents given to a prospective Subcontractor for the purpose of soliciting the Subcontractor's bid shall include either a copy of the bid cover or a separate information sheet setting forth the Project name, the Contract number (if available), the Agency (as noted in Article 2.1.6), and the Project's location.

17.8 The Commissioner's approval of a Subcontractor shall not relieve the Contractor of any of its responsibilities, duties, and liabilities hereunder. The Contractor shall be solely responsible to the City for the acts or defaults of its Subcontractor and of such Subcontractor's officers, agents, and employees, each of whom shall, for this purpose, be deemed to be the agent or employee of the Contractor to the extent of its subcontract.

17.9 If the Subcontractor fails to maintain the necessary facilities, skill, integrity, past experience, and financial resources (other than due to the Contractor's failure to make payments where required) to perform the Work in accordance with the terms and conditions of this Contract, the Contractor shall promptly notify the Commissioner and replace such Subcontractor with a newly approved Subcontractor in accordance with this Article 17.

17.10 The Contractor shall be responsible for ensuring that all Subcontractors performing Work at the Site maintain all insurance required by Law.

17.11 The Contractor shall promptly, upon request, file with the Engineer a conformed copy of the subcontract and its cost. The subcontract shall provide the following:

17.11.1 Payment to Subcontractors: The agreement between the Contractor and its Subcontractor shall contain the same terms and conditions as to method of payment for Work, labor, and materials, and as to retained percentages, as are contained in this Contract.

17.11.2 Prevailing Rate of Wages: The agreement between the Contractor and its Subcontractor shall include the prevailing wage rates and supplemental benefits to be paid in accordance with Labor Law Section 220.

17.11.3 Section 6-123 of the Administrative Code: Pursuant to the requirements of Section 6-123 of the Administrative Code, every agreement between the Contractor and a Subcontractor in excess of fifty thousand (\$50,000) dollars shall include a provision that the Subcontractor shall not engage in any unlawful discriminatory practice as defined in Title VIII of the Administrative Code (Section 8-101 *et seq.*).

17.11.4 All requirements required pursuant to federal and/or state grant agreement(s), if applicable to the Work.

17.12 The Commissioner may deduct from the amounts certified under this Contract to be due to the Contractor, the sum or sums due and owing from the Contractor to the Subcontractors according to the terms of the said subcontracts, and in case of dispute between the Contractor and its Subcontractor, or Subcontractors, as to the amount due and owing, the Commissioner may deduct and withhold from the amounts certified under this Contract to be due to the Contractor such sum or sums as may be claimed by such Subcontractor, or Subcontractors, in a sworn affidavit, to be due and owing until such time as such claim or claims shall have been finally resolved.

17.13 On contracts where performance bonds and payment bonds are executed, the Contractor shall include on each requisition for payment the following data: Subcontractor's name, value of the subcontract, total amount previously paid to Subcontractor for Work previously requisitioned, and the amount, including retainage, to be paid to the Subcontractor for Work included in the requisition.

17.14 On Contracts where performance bonds and payment bonds are not executed, the Contractor shall include with each requisition for payment submitted hereunder, a signed statement from each and every Subcontractor and/or Materialman for whom payment is requested in such requisition. Such signed statement shall be on the letterhead of the Subcontractor and/or Materialman for whom payment is requested and shall (i) verify that such Subcontractor and/or Materialman has been paid in full for all Work performed and/or material supplied to date, exclusive of any amount retained and any amount included on the current requisition, and (ii) state the total amount of retainage to date, exclusive of any amount retained on the current requisition.

ARTICLE 18. ASSIGNMENTS

18.1 The Contractor shall not assign, transfer, convey or otherwise dispose of this Contract, or the right to execute it, or the right, title or interest in or to it or any part thereof, or assign, by power of attorney or otherwise any of the monies due or to become due under this Contract, unless the previous written consent of the Commissioner shall first be obtained thereto, and the giving of any such consent to a particular assignment shall not dispense with the necessity of such consent to any further or other assignments.

18.2 Such assignment, transfer, conveyance or other disposition of this Contract shall not be valid until filed in the office of the Commissioner and the Comptroller, with the written consent of the Commissioner endorsed thereon or attached thereto.

18.3 Failure to obtain the previous written consent of the Commissioner to such an assignment, transfer, conveyance or other disposition, may result in the revocation and annulment of this Contract. The City shall thereupon be relieved and discharged from any further liability to the Contractor, its assignees, transferees or sublessees, who shall forfeit and lose all monies therefor earned under the Contract, except so much as may be required to pay the Contractor's employees.

18.4 The provisions of this clause shall not hinder, prevent, or affect an assignment by the Contractor for the benefit of its creditors made pursuant to the Laws of the State of New York.

18.5 This Contract may be assigned by the City to any corporation, agency or instrumentality having authority to accept such assignment.

CHAPTER V: CONTRACTOR'S SECURITY AND GUARANTEE

ARTICLE 19. SECURITY DEPOSIT

19.1 If performance and payment bonds are required, the City shall retain the bid security to ensure that the successful bidder executes the Contract and furnishes the required payment and performance security within ten (10) Days after notice of the award of the Contract. If the successful bidder fails to execute the Contract and furnish the required payment and performance security, the City shall retain such bid security as set forth in the Information for Bidders. If the successful bidder executes the

Contract and furnishes the required payment and performance security, the City shall return the bid security within a reasonable time after the furnishing of such bonds and execution of the Contract by the City.

19.2 If performance and payment bonds are not required, the bid security shall be retained by the City as security for the Contractor's faithful performance of the Contract. If partial payments are provided, the bid security will be returned to the Contractor after the sum retained under Article 21 equals the amount of the bid security, subject to other provisions of this Contract. If partial payments are not provided, the bid security will be released when final payment is certified by the City for payment.

19.3 If the Contractor is declared in default under Article 48 prior to the return of the deposit, or if any claim is made such as referred to in Article 23, the amount of such deposit, or so much thereof as the Comptroller may deem necessary, may be retained and then applied by the Comptroller:

19.3.1 To compensate the City for any expense, loss or damage suffered or incurred by reason of or resulting from such default, including the cost of re-letting and liquidated damages; or

19.3.2 To indemnify the City against any and all claims.

ARTICLE 20. PAYMENT GUARANTEE

20.1 On Contracts where one hundred (100%) percent performance bonds and payment bonds are executed, this Article 20 does not apply.

20.2 In the event the terms of this Contract do not require the Contractor to provide a payment bond or where the Contract does not require a payment bond for one hundred (100%) percent of the Contract price, the City shall, in accordance with the terms of this Article 20, guarantee payment of all lawful claims for:

20.2.1 Wages and compensation for labor performed and/or services rendered; and

20.2.2 Materials, equipment, and supplies provided, whether incorporated into the Work or not, when demands have been filed with the City as provided hereinafter by any person, firm, or corporation which furnished labor, material, equipment, supplies, or any combination thereof, in connection with the Work performed hereunder (hereinafter referred to as the "beneficiary") at the direction of the City or the Contractor.

20.3 The provisions of Article 20.2 are subject to the following limitations and conditions:

20.3.1 If the Contractor provides a payment bond for a value that is less than one hundred (100%) percent of the value of the Contract Work, the payment bond provided by the Contractor shall be primary (and non-contributing) to the payment guarantee provided under this Article 20.

20.3.2 The guarantee is made for the benefit of all beneficiaries as defined in Article 20.2 provided that those beneficiaries strictly adhere to the terms and conditions of Article 20.3.4 and 20.3.5.

20.3.3 Nothing in this Article 20 shall prevent a beneficiary providing labor, services or material for the Work from suing the Contractor for any amounts due and owing the beneficiary by the Contractor.

20.3.4 Every person who has furnished labor or material, to the Contractor or to a Subcontractor of the Contractor, in the prosecution of the Work and who has not been paid in full therefor before the expiration of a period of ninety (90) Days after the date on which the last of the labor was performed or material was furnished by him/her for which the claim is made, shall have the right to sue on this payment guarantee in his/her own name for the amount, or the balance thereof, unpaid at the time of commencement of the action; provided, however, that a person having a direct contractual relationship with a Subcontractor of the Contractor but no contractual relationship express or implied with the Contractor shall not have a right of action upon the guarantee unless he/she shall have given written notice to the Contractor within one hundred twenty (120) Days from the date on which the last of the labor was performed or the last of the material was furnished, for which his/her claim is made, stating with substantial accuracy the amount claimed and the name of the party to whom the material was furnished or for whom the labor was performed. The notice shall be served by delivering the same personally to the Contractor or by mailing the same by registered mail, postage prepaid, in an envelope addressed to the Contractor at any place where it maintains an office or conducts its business; provided, however, that where such notice is actually received by the Contractor by other means, such notice shall be deemed sufficient.

20.3.5 Except as provided in Labor Law Section 220-g, no action on this payment guarantee shall be commenced after the expiration of the one-year limitations period set forth in Section 137(4)(b) of the State Finance Law.

20.3.6 The Contractor shall promptly forward to the City any notice or demand received pursuant to Article 20.3.4. The Contractor shall inform the City of any defenses to the notice or demand and shall forward to the City any documents the City requests concerning the notice or demand.

20.3.7 All demands made against the City by a beneficiary of this payment guarantee shall be presented to the Engineer along with all written documentation concerning the demand which the Engineer deems reasonably appropriate or necessary, which may include, but shall not be limited to: the subcontract; any invoices presented to the Contractor for payment; the notarized statement of the beneficiary that the demand is due and payable, that a request for payment has been made of the Contractor and that the demand has not been paid by the Contractor within the time allowed for such payment by the subcontract; and copies of any correspondence between the beneficiary and the Contractor concerning such demand. The City shall notify the Contractor that a demand has been made. The Contractor shall inform the City of any defenses to the demand and shall forward to the City any documents the City requests concerning the demand.

20.3.8 The City shall make payment only if, after considering all defenses presented by the Contractor, it determines that the payment is due and owing to the beneficiary making the demand.

20.3.9 No beneficiary shall be entitled to interest from the City, or to any other costs, including, but not limited to, attorneys' fees, except to the extent required by State Finance Law Section 137.

20.4 Upon the receipt by the City of a demand pursuant to this Article 20, the City may withhold from any payment otherwise due and owing to the Contractor under this Contract an amount sufficient to satisfy the demand.

20.4.1 In the event the City determines that the demand is valid, the City shall notify the Contractor of such determination and the amount thereof and direct the Contractor to immediately pay such amount to the beneficiary. In the event the Contractor, within seven (7) Days of receipt of such notification from the City, fails to pay the beneficiary, such failure shall constitute an automatic and irrevocable assignment of payment by the Contractor to the beneficiary for the amount of the demand determined by the City to be valid. The Contractor, without further notification or other process, hereby gives its unconditional consent to such assignment of payment to the beneficiary and authorizes the City, on its behalf, to take all necessary actions to implement such assignment of payment, including without limitation the execution of any instrument or documentation necessary to effectuate such assignment.

20.4.2 In the event that the amount otherwise due and owing to the Contractor by the City is insufficient to satisfy such demand, the City may, at its option, require payment from the Contractor of an amount sufficient to cover such demand and exercise any other right to require or recover payment which the City may have under Law or Contract.

20.4.3 In the event the City determines that the demand is invalid, any amount withheld pending the City's review of such demand shall be paid to the Contractor, provided, however, no lien has been filed. In the event a claim or an action has been filed, the terms and conditions set forth in Article 23 shall apply. In the event a lien has been filed, the parties will be governed by the provisions of the Lien Law of the State of New York.

20.5 The provisions of this Article 20 shall not prevent the City and the Contractor from resolving disputes in accordance with the PPB Rules, where applicable.

20.6 In the event the City determines that the beneficiary is entitled to payment pursuant to this Article 20, such determination and any defenses and counterclaims raised by the Contractor shall be taken into account in evaluating the Contractor's performance.

20.7 Nothing in this Article 20 shall relieve the Contractor of the obligation to pay the claims of all persons with valid and lawful claims against the Contractor relating to the Work.

20.8 The Contractor shall not require any performance, payment or other bonds of any Subcontractor if this Contract does not require such bonds of the Contractor.

20.9 The payment guarantee made pursuant to this Article 20 shall be construed in a manner consistent with Section 137 of the State Finance Law and shall afford to persons furnishing labor or materials to the Contractor or its Subcontractors in the prosecution of the Work under this Contract all of the rights and remedies afforded to such persons by such section, including but not limited to, the right to commence an action against the City on the payment guarantee provided by this Article 20 within the one-year limitations period set forth in Section 137(4)(b).

ARTICLE 21. RETAINED PERCENTAGE

21.1 If this Contract requires one hundred (100%) percent performance and payment security, then as further security for the faithful performance of this Contract, the Commissioner shall deduct, and

retain until the substantial completion of the Work, five (5%) percent of the value of Work certified for payment in each partial payment voucher.

21.2 If this Contract does not require one hundred (100%) percent performance and payment security and if the price for which this Contract was awarded does not exceed one million (\$1,000,000) dollars, then as further security for the faithful performance of this Contract, the Commissioner shall deduct, and retain until the substantial completion of the Work, five (5%) percent of the value of Work certified for payment in each partial payment voucher.

21.3 If this Contract does not require one hundred (100%) percent performance and payment security and if the price for which this Contract was awarded exceeds one million (\$1,000,000) dollars, then as further security for the faithful performance of this Contract, the Commissioner shall deduct, and retain until the substantial completion of the Work, up to ten (10%) percent of the value of Work certified for payment in each partial payment voucher. The percentage to be retained is set forth in Schedule A of the General Conditions.

ARTICLE 22. INSURANCE

22.1 Types of Insurance: The Contractor shall procure and maintain the following types of insurance if, and as indicated, in Schedule A of the General Conditions (with the minimum limits and special conditions specified in Schedule A). Such insurance shall be maintained from the date the Contractor is required to provide Proof of Insurance pursuant to Article 22.3.1 through the date of completion of all required Work (including punch list work as certified in writing by the Resident Engineer), except for insurance required pursuant to Article 22.1.4, which may terminate upon Substantial Completion of the Contract. All insurance shall meet the requirements set forth in this Article 22. Wherever this Article requires that insurance coverage be "at least as broad" as a specified form (including all ISO forms), there is no obligation that the form itself be used, provided that the Contractor can demonstrate that the alternative form or endorsement contained in its policy provides coverage at least as broad as the specified form.

22.1.1 Commercial General Liability Insurance: The Contractor shall provide Commercial General Liability Insurance covering claims for property damage and/or bodily injury, including death, which may arise from any of the operations under this Contract. Coverage under this insurance shall be at least as broad as that provided by the latest edition of Insurance Services Office ("ISO") Form CG 0001. Such insurance shall be "occurrence" based rather than "claims-made" and include, without limitation, the following types of coverage: premises operations; products and completed operations; contractual liability (including the tort liability of another assumed in a contract); broad form property damage; independent contractors; explosion, collapse and underground (XCU); construction means and methods; and incidental malpractice. Such insurance shall contain a "per project" aggregate limit, as specified in Schedule A, that applies separately to operations under this Contract.

22.1.1(a) Such Commercial General Liability Insurance shall name the City as an Additional Insured. Coverage for the City shall specifically include the City's officials and employees, be at least as broad as the latest edition of ISO Form CG 20 10 and provide completed operations coverage at least as broad as the latest edition of ISO Form CG 20 37.

22.1.1(b) Such Commercial General Liability Insurance shall name all other entities designated as additional insureds in Schedule A but only for claims arising from the

Contractor's operations under this Contract, with coverage at least as broad as the latest edition of ISO Form CG-20-26.

22.1.1(c) If the Work requires a permit from the Department of Buildings pursuant to 1 RCNY Section 101-08, the Contractor shall provide Commercial General Liability Insurance with limits of at least those required by 1 RCNY section 101-08 or greater limits required by the Agency in accordance with Schedule A. If the Work does not require such a permit, the minimum limits shall be those provided for in Schedule A.

22.1.1(d) If any of the Work includes repair of a waterborne vessel owned by or to be delivered to the City, such Commercial General Liability shall include, or be endorsed to include, Ship Repairer's Legal Liability Coverage to protect against, without limitation, liability arising from navigation of such vessels prior to delivery to and acceptance by the City.

22.1.2 Workers' Compensation Insurance, Employers' Liability Insurance, and Disability Benefits Insurance: The Contractor shall provide, and shall cause its Subcontractors to provide, Workers Compensation Insurance, Employers' Liability Insurance, and Disability Benefits Insurance in accordance with the Laws of the State of New York on behalf of all employees providing services under this Contract (except for those employees, if any, for which the Laws require insurance only pursuant to Article 22.1.3).

22.1.3 United States Longshoremen's and Harbor Workers Act and/or Jones Act Insurance: If specified in Schedule A of the General Conditions or if required by Law, the Contractor shall provide insurance in accordance with the United States Longshoremen's and Harbor Workers Act and/or the Jones Act, on behalf of all qualifying employees providing services under this Contract.

22.1.4 Builders Risk Insurance: If specified in Schedule A of the General Conditions, the Contractor shall provide Builders Risk Insurance on a completed value form for the total value of the Work through Substantial Completion of the Work in its entirety. Such insurance shall be provided on an All Risk basis and include coverage, without limitation, for windstorm (including named windstorm), storm surge, flood and earth movement. Unless waived by the Commissioner, it shall include coverage for ordinance and law, demolition and increased costs of construction, debris removal, pollutant clean up and removal, and expediting costs. Such insurance shall cover, without limitation, (a) all buildings and/or structures involved in the Work, as well as temporary structures at the Site, and (b) any property that is intended to become a permanent part of such building or structure, whether such property is on the Site, in transit or in temporary storage. Policies shall name the Contractor as Named Insured and list the City as both an Additional Insured and a Loss Payee as its interest may appear.

22.1.4(a) Policies of such insurance shall specify that, in the event a loss occurs at an occupied facility, occupancy of such facility is permitted without the consent of the issuing insurance company.

22.1.4(b) Such insurance may be provided through an Installation Floater, at the Contractor's option, if it otherwise conforms with the requirements of this Article 22.1.4.

22.1.5 Commercial Automobile Liability Insurance: The Contractor shall provide Commercial Automobile Liability Insurance for liability arising out of ownership,

maintenance or use of any owned (if any), non-owned and hired vehicles to be used in connection with this Contract. Coverage shall be at least as broad as the latest edition of ISO Form CA0001. If vehicles are used for transporting hazardous materials, the Automobile Liability Insurance shall be endorsed to provide pollution liability broadened coverage for covered vehicles (endorsement CA 99 48) as well as proof of MCS 90.

22.1.6 Contractors Pollution Liability Insurance: If specified in Schedule A of the General Conditions, the Contractor shall maintain, or cause the Subcontractor doing such Work to maintain, Contractors Pollution Liability Insurance covering bodily injury and property damage. Such insurance shall provide coverage for actual, alleged or threatened emission, discharge, dispersal, seepage, release or escape of pollutants (including asbestos), including any loss, cost or expense incurred as a result of any cleanup of pollutants (including asbestos) or in the investigation, settlement or defense of any claim, action, or proceedings arising from the operations under this Contract. Such insurance shall be in the Contractor's name and list the City as an Additional Insured and any other entity specified in Schedule A. Coverage shall include, without limitation, (a) loss of use of damaged property or of property that has not been physically injured, (b) transportation, and (c) non-owned disposal sites.

22.1.6(a) Coverage for the City as Additional Insured shall specifically include the City's officials and employees and be at least as broad as provided to the Contractor for this Project.

22.1.6(b) If such insurance is written on a claims-made policy, such policy shall have a retroactive date on or before the effective date of this Contract, and continuous coverage shall be maintained, or an extended discovery period exercised, for a period of not less than three (3) years from the time the Work under this Contract is completed.

22.1.7 Marine Insurance:

22.1.7(a) Marine Protection and Indemnity Insurance: If specified in Schedule A of the General Conditions or if the Contractor engages in marine operations in the execution of any part of the Work, the Contractor shall maintain, or cause the Subcontractor doing such Work to maintain, Marine Protection and Indemnity Insurance with coverage at least as broad as Form SP-23. The insurance shall provide coverage for the Contractor or Subcontractor (whichever is doing this Work) and for the City (together with its officials and employees) and any other entity specified in Schedule A as an Additional Insured for bodily injury and property damage arising from marine operations under this Contract. Coverage shall include, without limitation, injury or death of crew members (if not fully provided through other insurance), removal of wreck, damage to piers, wharves and other fixed or floating objects and loss of or damage to any other vessel or craft, or to property on such other vessel or craft.

22.1.7(b) Hull and Machinery Insurance: If specified in Schedule A of the General Conditions or if the Contractor engages in marine operations in the execution of any part of the Work, the Contractor shall maintain, or cause the Subcontractor doing such Work to maintain, Hull and Machinery Insurance with coverage for the Contractor or Subcontractor (whichever is doing this Work) and for the City (together with its officials and employees) as Additional Insured at least as broad as the latest edition of American Institute Tug Form for all tugs used under this

Contract and Collision Liability at least as broad as the latest edition of American Institute Hull Clauses.

22.1.7(c) Marine Pollution Liability Insurance: If specified in Schedule A of the General Conditions or if the Contractor engages in marine operations in the execution of any part of the Work, the Contractor shall maintain, or cause the Subcontractor doing such Work to maintain, Marine Pollution Liability Insurance covering itself (or the Subcontractor doing such Work) as Named Insured and the City (together with its officials and employees) and any other entity specified in Schedule A as an Additional Insured. Coverage shall be at least as broad as that provided by the latest edition of Water Quality Insurance Syndicate Form and include, without limitation, liability arising from the discharge or substantial threat of a discharge of oil, or from the release or threatened release of a hazardous substance including injury to, or economic losses resulting from, the destruction of or damage to real property, personal property or natural resources.

22.1.8 The Contractor shall provide such other types of insurance, at such minimum limits and with such conditions, as are specified in Schedule A of the General Conditions.

22.2 General Requirements for Insurance Coverage and Policies:

22.2.1 All required insurance policies shall be maintained with companies that may lawfully issue the required policy and have an A.M. Best rating of at least A-/VII or a Standard and Poor's rating of at least A, unless prior written approval is obtained from the City Corporation Counsel.

22.2.2 The Contractor shall be solely responsible for the payment of all premiums for all required policies and all deductibles and self-insured retentions to which such policies are subject, whether or not the City is an insured under the policy.

22.2.3 In his/her sole discretion, the Commissioner may, subject to the approval of the Comptroller and the City Corporation Counsel, accept Letters of Credit and/or custodial accounts in lieu of required insurance.

22.2.4 The City's limits of coverage for all types of insurance required pursuant to Schedule A of the General Conditions shall be the greater of (i) the minimum limits set forth in Schedule A or (ii) the limits provided to the Contractor as Named Insured under all primary, excess, and umbrella policies of that type of coverage.

22.2.5 The Contractor may satisfy its insurance obligations under this Article 22 through primary policies or a combination of primary and excess/umbrella policies, so long as all policies provide the scope of coverage required herein.

22.2.6 Policies of insurance provided pursuant to this Article 22 shall be primary and non-contributing to any insurance or self-insurance maintained by the City.

22.3 Proof of Insurance:

22.3.1 For all types of insurance required by Article 22.1 and Schedule A, except for insurance required by Articles 22.1.4 and 22.1.7, the Contractor shall file proof of insurance in accordance with this Article 22.3 within ten (10) Days of award. For insurance

provided pursuant to Articles 22.1.4 and 22.1.7, proof shall be filed by a date specified by the Commissioner or ten (10) Days prior to the commencement of the portion of the Work covered by such policy, whichever is earlier.

22.3.2 For Workers' Compensation Insurance provided pursuant to Article 22.1.2, the Contractor shall submit one of the following forms: C-105.2 Certificate of Workers' Compensation Insurance; U-26.3 - State Insurance Fund Certificate of Workers' Compensation Insurance; Request for WC/DB Exemption (Form CE-200); equivalent or successor forms used by the New York State Workers' Compensation Board; or other proof of insurance in a form acceptable to the Commissioner. For Disability Benefits Insurance provided pursuant to Article 22.1.2, the Contractor shall submit DB-120.1 - Certificate Of Insurance Coverage Under The NYS Disability Benefits Law, Request for WC/DB Exemption (Form CE-200); equivalent or successor forms used by the New York State Workers' Compensation Board; or other proof of insurance in a form acceptable to the Commissioner. ACORD forms are not acceptable.

22.3.3 For policies provided pursuant to all of Article 22.1 other than Article 22.1.2, the Contractor shall submit one or more Certificates of Insurance on forms acceptable to the Commissioner. All such Certificates of Insurance shall certify (a) the issuance and effectiveness of such policies of insurance, each with the specified minimum limits (b) for insurance secured pursuant to Article 22.1.1 that the City and any other entity specified in Schedule A is an Additional Insured thereunder; (c) in the event insurance is required pursuant to Article 22.1.6 and/or Article 22.1.7, that the City is an Additional Insured thereunder; (d) the company code issued to the insurance company by the National Association of Insurance Commissioners (the NAIC number); and (e) the number assigned to the Contract by the City. All such Certificates of Insurance shall be accompanied by either a duly executed "Certification by Insurance Broker or Agent" in the form contained in Part III of Schedule A or copies of all policies referenced in such Certificate of Insurance as certified by an authorized representative of the issuing insurance carrier. If any policy is not available at the time of submission, certified binders may be submitted until such time as the policy is available, at which time a certified copy of the policy shall be submitted.

22.3.4 Documentation confirming renewals of insurance shall be submitted to the Commissioner prior to the expiration date of coverage of policies required under this Contract. Such proofs of insurance shall comply with the requirements of Articles 22.3.2 and 22.3.3.

22.3.5 The Contractor shall be obligated to provide the City with a copy of any policy of insurance provided pursuant to this Article 22 upon the demand for such policy by the Commissioner or the City Corporation Counsel.

22.4 Operations of the Contractor:

22.4.1 The Contractor shall not commence the Work unless and until all required certificates have been submitted to and accepted by the Commissioner. Acceptance by the Commissioner of a certificate does not excuse the Contractor from securing insurance consistent with all provisions of this Article 22 or of any liability arising from its failure to do so.

22.4.2 The Contractor shall be responsible for providing continuous insurance coverage in the manner, form, and limits required by this Contract and shall be authorized to perform Work only during the effective period of all required coverage.

22.4.3 In the event that any of the required insurance policies lapse, are revoked, suspended or otherwise terminated, for whatever cause, the Contractor shall immediately stop all Work, and shall not recommence Work until authorized in writing to do so by the Commissioner. Upon quitting the Site, except as otherwise directed by the Commissioner, the Contractor shall leave all plant, materials, equipment, tools, and supplies on the Site. Contract time shall continue to run during such periods and no extensions of time will be granted. The Commissioner may also declare the Contractor in default for failure to maintain required insurance.

22.4.4 In the event the Contractor receives notice, from an insurance company or other person, that any insurance policy required under this Article 22 shall be cancelled or terminated (or has been cancelled or terminated) for any reason, the Contractor shall immediately forward a copy of such notice to both the Commissioner and the New York City Comptroller, attn: Office of Contract Administration, Municipal Building, One Centre Street, room 1005, New York, New York 10007. Notwithstanding the foregoing, the Contractor shall ensure that there is no interruption in any of the insurance coverage required under this Article 22.

22.4.5 Where notice of loss, damage, occurrence, accident, claim or suit is required under an insurance policy maintained in accordance with this Article 22, the Contractor shall notify in writing all insurance carriers that issued potentially responsive policies of any such event relating to any operations under this Contract (including notice to Commercial General Liability insurance carriers for events relating to the Contractor's own employees) no later than 20 days after such event. For any policy where the City is an Additional Insured, such notice shall expressly specify that "this notice is being given on behalf of the City of New York as Insured as well as the Named Insured." Such notice shall also contain the following information: the number of the insurance policy, the name of the named insured, the date and location of the damage, occurrence, or accident, and the identity of the persons or things injured, damaged or lost. The Contractor shall simultaneously send a copy of such notice to the City of New York c/o Insurance Claims Specialist, Affirmative Litigation Division, New York City Law Department, 100 Church Street, New York, New York 10007.

22.4.6 In the event of any loss, accident, claim, action, or other event that does or can give rise to a claim under any insurance policy required under this Article 22, the Contractor shall at all times fully cooperate with the City with regard to such potential or actual claim.

22.5 Subcontractor Insurance: In the event the Contractor requires any Subcontractor to procure insurance with regard to any operations under this Contract and requires such Subcontractor to name the Contractor as an Additional Insured thereunder, the Contractor shall ensure that the Subcontractor name the City, including its officials and employees, as an Additional Insured with coverage at least as broad as the most recent edition of ISO Form CG 20-26.

22.6 Wherever reference is made in Article 7 or this Article 22 to documents to be sent to the Commissioner (e.g., notices, filings, or submissions), such documents shall be sent to the address set forth in Schedule A of the General Conditions. In the event no address is set forth in Schedule A, such documents are to be sent to the Commissioner's address as provided elsewhere in this Contract.

22.7 Apart from damages or losses covered by insurance provided pursuant to Articles 22.1.2, 22.1.3, or 22.1.5, the Contractor waives all rights against the City, including its officials and employees, for any damages or losses that are covered under any insurance required under this Article 22 (whether or

not such insurance is actually procured or claims are paid thereunder) or any other insurance applicable to the operations of the Contractor and/or its employees, agents, or Subcontractors.

22.8 In the event the Contractor utilizes a self-insurance program to satisfy any of the requirements of this Article 22, the Contractor shall ensure that any such self-insurance program provides the City with all rights that would be provided by traditional insurance under this Article 22, including but not limited to the defense and indemnification obligations that insurers are required to undertake in liability policies.

22.9 Materiality/Non-Waiver: The Contractor's failure to secure policies in complete conformity with this Article 22, or to give an insurance company timely notice of any sort required in this Contract or to do anything else required by this Article 22 shall constitute a material breach of this Contract. Such breach shall not be waived or otherwise excused by any action or inaction by the City at any time.

22.10 Pursuant to General Municipal Law Section 108, this Contract shall be void and of no effect unless Contractor maintains Workers' Compensation Insurance for the term of this Contract to the extent required and in compliance with the New York State Workers' Compensation Law.

22.11 Other Remedies: Insurance coverage provided pursuant to this Article 22 or otherwise shall not relieve the Contractor of any liability under this Contract, nor shall it preclude the City from exercising any rights or taking such other actions available to it under any other provisions of this Contract or Law.

ARTICLE 23. MONEY RETAINED AGAINST CLAIMS

23.1 If any claim shall be made by any person or entity (including Other Contractors with the City on this Project) against the City or against the Contractor and the City for any of the following:

- (a) An alleged loss, damage, injury, theft or vandalism of any of the kinds referred to in Articles 7 and 12, plus the reasonable costs of defending the City, which in the opinion of the Comptroller may not be paid by an insurance company (for any reason whatsoever); or
- (b) An infringement of copyrights, patents or use of patented articles, tools, etc., as referred to in Article 57; or
- (c) Damage claimed to have been caused directly or indirectly by the failure of the Contractor to perform the Work in strict accordance with this Contract,

the amount of such claim, or so much thereof as the Comptroller may deem necessary, may be withheld by the Comptroller, as security against such claim, from any money due hereunder. The Comptroller, in his/her discretion, may permit the Contractor to substitute other satisfactory security in lieu of the monies so withheld.

23.2 If an action on such claim is timely commenced and the liability of the City, or the Contractor, or both, shall have been established therein by a final judgment of a court of competent jurisdiction, or if such claim shall have been admitted by the Contractor to be valid, the Comptroller shall pay such judgment or admitted claim out of the monies retained by the Comptroller under the provisions of this Article 23, and return the balance, if any, without interest, to the Contractor.

ARTICLE 24. MAINTENANCE AND GUARANTY

24.1 The Contractor shall promptly repair, replace, restore or rebuild, as the Commissioner may determine, any finished Work in which defects of materials or workmanship may appear or to which damage may occur because of such defects, during the one (1) year period subsequent to the date of Substantial Completion (or use and occupancy in accordance with Article 16), except where other periods of maintenance and guaranty are provided for in Schedule A.

24.2 As security for the faithful performance of its obligations hereunder, the Contractor, upon filing its requisition for payment on Substantial Completion, shall deposit with the Commissioner a sum equal to one (1%) percent of the price (or the amount fixed in Schedule A of the General Conditions) in cash or certified check upon a state or national bank and trust company or a check of such bank and trust company signed by a duly authorized officer thereof and drawn to the order of the Comptroller, or obligations of the City, which the Comptroller may approve as of equal value with the sum so required.

24.3 In lieu of the above, the Contractor may make such security payment to the City by authorizing the Commissioner in writing to deduct the amount from the Substantial Completion payment which shall be deemed the deposit required above.

24.4 If the Contractor has faithfully performed all of its obligations hereunder the Commissioner shall so certify to the Comptroller within five (5) Days after the expiration of one (1) year from the date of Substantial Completion and acceptance of the Work or within thirty (30) Days after the expiration of the guarantee period fixed in the Specifications. The security payment shall be repaid to the Contractor without interest within thirty (30) Days after certification by the Commissioner to the Comptroller that the Contractor has faithfully performed all of its obligations hereunder.

24.5 Notice by the Commissioner to the Contractor to repair, replace, rebuild or restore such defective or damaged Work shall be timely, pursuant to this article, if given not later than ten (10) Days subsequent to the expiration of the one (1) year period or other periods provided for herein.

24.6 If the Contractor shall fail to repair, replace, rebuild or restore such defective or damaged Work promptly after receiving such notice, the Commissioner shall have the right to have the Work done by others in the same manner as provided for in the completion of a defaulted Contract, under Article 51.

24.7 If the security payment so deposited is insufficient to cover the cost of such Work, the Contractor shall be liable to pay such deficiency on demand by the Commissioner.

24.8 The Engineer's certificate setting forth the fair and reasonable cost of repairing, replacing, rebuilding or restoring any damaged or defective Work when performed by one other than the Contractor, shall be binding and conclusive upon the Contractor as to the amount thereof.

24.9 The Contractor shall obtain all manufacturers' warranties and guaranties of all equipment and materials required by this Contract in the name of the City and shall deliver same to the Commissioner. All of the City's rights and title and interest in and to said manufacturers' warranties and guaranties may be assigned by the City to any subsequent purchasers of such equipment and materials or lessees of the premises into which the equipment and materials have been installed.

CHAPTER VI: CHANGES, EXTRA WORK, AND DOCUMENTATION OF CLAIM

ARTICLE 25. CHANGES

25.1 Changes may be made to this Contract only as duly authorized in writing by the Commissioner in accordance with the Law and this Contract. All such changes, modifications, and amendments will become a part of the Contract. Work so ordered shall be performed by the Contractor.

25.2 Contract changes will be made only for Work necessary to complete the Work included in the original scope of the Contract and/or for non-material changes to the scope of the Contract. Changes are not permitted for any material alteration in the scope of Work in the Contract.

25.3 The Contractor shall be entitled to a price adjustment for Extra Work performed pursuant to a written change order. Adjustments to price shall be computed in one or more of the following ways:

25.3.1 By applicable unit prices specified in the Contract; and/or

25.3.2 By agreement of a fixed price; and/or

25.3.3 By time and material records; and/or

25.3.4 In any other manner approved by the CCPO.

25.4 All payments for change orders are subject to pre-audit by the Engineering Audit Officer and may be post-audited by the Comptroller and/or the Agency.

ARTICLE 26. METHODS OF PAYMENT FOR OVERRUNS AND EXTRA WORK

26.1 Overrun of Unit Price Item: An overrun is any quantity of a unit price item which the Contractor is directed to provide which is in excess of one hundred twenty-five (125%) percent of the estimated quantity for that item set forth in the bid schedule.

26.1.1 For any unit price item, the Contractor will be paid at the unit price bid for any quantity up to one hundred twenty-five (125%) percent of the estimated quantity for that item set forth in the bid schedule. If during the progress of the Work, the actual quantity of any unit price item required to complete the Work approaches the estimated quantity for that item, and for any reason it appears that the actual quantity of any unit price item necessary to complete the Work will exceed the estimated quantity for that item by twenty-five (25%) percent, the Contractor shall immediately notify the Engineer of such anticipated overrun. The Contractor shall not be compensated for any quantity of a unit price item provided which is in excess of one hundred twenty-five (125%) percent of the estimated quantity for that item set forth in the bid schedule without written authorization from the Engineer.

26.1.2 If the actual quantity of any unit price item necessary to complete the Work will exceed one hundred twenty five (125%) percent of the estimated quantity for that item set forth in the bid schedule, the City reserves the right and the Contractor agrees to negotiate a new unit price for such item. In no event shall such negotiated new unit price exceed the unit bid price. If the City and Contractor cannot agree on a new unit price, then the City shall order the Contractor and the Contractor agrees to provide additional quantities of

the item on the basis of time and material records for the actual and reasonable cost as determined under Article 26.2, but in no event at a unit price exceeding the unit price bid.

26.2 **Extra Work:** For **Extra Work** where payment is by agreement on a fixed price in accordance with Article 25.3.2, the price to be paid for such **Extra Work** shall be based on the fair and reasonable estimated cost of the items set forth below. For **Extra Work** where payment is based on time and material records in accordance with Article 25.3.3, the price to be paid for such **Extra Work** shall be the actual and reasonable cost of the items set forth below, calculated in accordance with the formula specified therein, if any.

26.2.1 Necessary materials (including transportation to the Site); plus

26.2.2 Necessary direct labor, including payroll taxes (subject to statutory wage caps) and supplemental benefits; plus

26.2.3 Sales and personal property taxes, if any, required to be paid on materials not incorporated into such **Extra Work**; plus

26.2.4 Reasonable rental value of Contractor-owned (or Subcontractor-owned, as applicable), necessary plant and equipment other than **Small Tools**, plus fuel/energy costs. Except for fuel costs for pick-up trucks which shall be reimbursed based on a consumption of five (5) gallons per shift, fuel costs shall be reimbursed based on actual costs or, in the absence of auditable documentation, the following fuel consumption formula per operating hour: $(.035) \times (\text{HP rating}) \times (\text{Fuel cost/gallon})$. Reasonable rental value is defined as the lower of either seventy-five percent of the monthly prorated rental rates established in "The AED Green Book, Rental Rates and Specifications for Construction Equipment" published by Equipment Watch (the "Green Book"), or seventy-five percent of the monthly prorated rental rates established in the "Rental Rate Blue Book for Construction Equipment" published by Equipment Watch (the "Blue Book") (the applicable Blue Book rate being for rental only without the addition of any operational costs listed in the Blue Book). The reasonable rental value is deemed to be inclusive of all operating costs except for fuel/energy consumption and equipment operator's wages/costs. For multiple shift utilization, reimbursement shall be calculated as follows: first shift shall be seventy-five (75%) percent of such rental rates; second shift shall be sixty (60%) percent of the first shift rate; and third shift shall be forty (40%) percent of the first shift rate. Equipment on standby shall be reimbursed at one-third (1/3) the prorated monthly rental rate. Contractor-owned (or Subcontractor-owned, as applicable) equipment includes equipment from rental companies affiliated with or controlled by the Contractor (or Subcontractor, as applicable), as determined by the Commissioner. In establishing cost reimbursement for non-operating Contractor-owned (or Subcontractor-owned, as applicable) equipment (scaffolding, sheeting systems, road plates, etc.), the City may restrict reimbursement to a purchase-salvage/life cycle basis if less than the computed rental costs; plus

26.2.5 Necessary installation and dismantling of such plant and equipment, including transportation to and from the Site, if any, provided that, in the case of non-Contractor-owned (or non-Subcontractor-owned, as applicable) equipment rented from a third party, the cost of installation and dismantling are not allowable if such costs are included in the rental rate; plus

26.2.6 Necessary fees charged by governmental entities; plus

26.2.7 Necessary construction-related service fees charged by non-governmental entities, such as landfill tipping fees; plus

26.2.8 Reasonable rental costs of non-Contractor-owned (or non-Subcontractor-owned, as applicable) necessary plant and equipment other than Small Tools, plus fuel/energy costs. Except for fuel costs for pick-up trucks which shall be reimbursed based on a consumption of five (5) gallons per shift, fuel costs shall be reimbursed based on actual costs or, in the absence of auditable documentation, the following fuel consumption formula per hour of operation: $(.035) \times (\text{HP rating}) \times (\text{Fuel cost/gallon})$. In lieu of renting, the City reserves the right to direct the purchase of non-operating equipment (scaffolding, sheeting systems, road plates, etc.), with payment on a purchase-salvage/life cycle basis, if less than the projected rental costs; plus

26.2.9 Workers' Compensation Insurance, and any insurance coverage expressly required by the City for the performance of the Extra Work which is different than the types of insurance required by Article 22 and Schedule A of the General Conditions. The cost of Workers' Compensation Insurance is subject to applicable payroll limitation caps and shall be based upon the carrier's Manual Rate for such insurance derived from the applicable class Loss Cost ("LC") and carrier's Lost Cost Multiplier ("LCM") approved by the New York State Department of Financial Services, and with the exception of experience rating, rate modifiers as promulgated by the New York Compensation Insurance Rating Board ("NYCIRB"); plus

26.2.10 Additional costs incurred as a result of the Extra Work for performance and payment bonds; plus

26.2.11 Twelve percent (12%) percent of the total of items in Articles 26.2.1 through 26.2.5 as compensation for overhead, except that no percentage for overhead will be allowed on Payroll Taxes or on the premium portion of overtime pay or on sales and personal property taxes. Overhead shall include without limitation, all costs and expenses in connection with administration, management superintendence, small tools, and insurance required by Schedule A of the General Conditions other than Workers' Compensation Insurance; plus

26.2.12 Ten (10%) percent of the total of items in Articles 26.2.1 through 26.2.5, plus the items in Article 26.2.11, as compensation for profit, except that no percentage for profit will be allowed on Payroll Taxes or on the premium portion of overtime pay or on sales and personal property taxes; plus

26.2.13 Five (5%) percent of the total of items in Articles 26.2.6 through 26.2.10 as compensation for overhead and profit.

26.3 Where the Extra Work is performed in whole or in part by other than the Contractor's own forces pursuant to Article 26.2, the Contractor shall be paid, subject to pre-audit by the Engineering Audit Officer, the cost of such Work computed in accordance with Article 26.2 above, plus an additional allowance of five (5%) percent to cover the Contractor's overhead and profit.

26.4 Where a change is ordered, involving both Extra Work and omitted or reduced Contract Work, the Contract price shall be adjusted, subject to pre-audit by the EAO, in an amount based on the difference between the cost of such Extra Work and of the omitted or reduced Work.

26.5 Where the Contractor and the Commissioner can agree upon a fixed price for Extra Work in accordance with Article 25.3.2 or another method of payment for Extra Work in accordance with

Article 25.3.4, or for Extra Work ordered in connection with omitted Work, such method, subject to pre-audit by the EAO, may, at the option of the Commissioner, be substituted for the cost plus a percentage method provided in Article 26.2; provided, however, that if the Extra Work is performed by a Subcontractor, the Contractor shall not be entitled to receive more than an additional allowance of five (5%) percent for overhead and profit over the cost of such Subcontractor's Work as computed in accordance with Article 26.2.

ARTICLE 27. RESOLUTION OF DISPUTES

27.1 All disputes between the City and the Contractor of the kind delineated in this Article 27.1 that arise under, or by virtue of, this Contract shall be finally resolved in accordance with the provisions of this Article 27 and the PPB Rules. This procedure for resolving all disputes of the kind delineated herein shall be the exclusive means of resolving any such disputes.

27.1.1 This Article 27 shall not apply to disputes concerning matters dealt with in other sections of the PPB Rules, or to disputes involving patents, copyrights, trademarks, or trade secrets (as interpreted by the courts of New York State) relating to proprietary rights in computer software.

27.1.2 This Article 27 shall apply only to disputes about the scope of Work delineated by the Contract, the interpretation of Contract documents, the amount to be paid for Extra Work or disputed work performed in connection with the Contract, the conformity of the Contractor's Work to the Contract, and the acceptability and quality of the Contractor's Work; such disputes arise when the Engineer, Resident Engineer, Engineering Audit Officer, or other designee of the Commissioner makes a determination with which the Contractor disagrees.

27.2 All determinations required by this Article 27 shall be made in writing clearly stated, with a reasoned explanation for the determination based on the information and evidence presented to the party making the determination. Failure to make such determination within the time required by this Article 27 shall be deemed a non-determination without prejudice that will allow application to the next level.

27.3 During such time as any dispute is being presented, heard, and considered pursuant to this Article 27, the Contract terms shall remain in force and the Contractor shall continue to perform Work as directed by the ACCO or the Engineer. Failure of the Contractor to continue Work as directed shall constitute a waiver by the Contractor of its claim.

27.4 Presentation of Disputes to Commissioner.

Notice of Dispute and Agency Response. The Contractor shall present its dispute in writing ("Notice of Dispute") to the Commissioner within thirty (30) Days of receiving written notice of the determination or action that is the subject of the dispute. This notice requirement shall not be read to replace any other notice requirements contained in the Contract. The Notice of Dispute shall include all the facts, evidence, documents, or other basis upon which the Contractor relies in support of its position, as well as a detailed computation demonstrating how any amount of money claimed by the Contractor in the dispute was arrived at. Within thirty (30) Days after receipt of the detailed written submission comprising the complete Notice of Dispute, the Engineer, Resident Engineer, Engineering Audit Officer, or other designee of the Commissioner shall submit to the Commissioner all materials he or she deems pertinent to the dispute. Following initial submissions to the Commissioner, either party may demand of the other the production of any document or other material the demanding party believes may be relevant to the dispute. The requested party shall produce all relevant materials that are not otherwise

protected by a legal privilege recognized by the courts of New York State. Any question of relevancy shall be determined by the Commissioner whose decision shall be final. Willful failure of the Contractor to produce any requested material whose relevancy the Contractor has not disputed, or whose relevancy has been affirmatively determined, shall constitute a waiver by the Contractor of its claim.

27.4.1 Commissioner Inquiry. The Commissioner shall examine the material and may, in his or her discretion, convene an informal conference with the Contractor, the ACCO, and the Engineer, Resident Engineer, Engineering Audit Officer, or other designee of the Commissioner to resolve the issue by mutual consent prior to reaching a determination. The Commissioner may seek such technical or other expertise as he or she shall deem appropriate, including the use of neutral mediators, and require any such additional material from either or both parties as he or she deems fit. The Commissioner's ability to render, and the effect of, a decision hereunder shall not be impaired by any negotiations in connection with the dispute presented, whether or not the Commissioner participated therein. The Commissioner may or, at the request of any party to the dispute, shall compel the participation of any Other Contractor with a contract related to the Work of this Contract, and that Contractor shall be bound by the decision of the Commissioner. Any Other Contractor thus brought into the dispute resolution proceeding shall have the same rights and obligations under this Article 27 as the Contractor initiating the dispute.

27.4.2 Commissioner Determination. Within thirty (30) Days after the receipt of all materials and information, or such longer time as may be agreed to by the parties, the Commissioner shall make his or her determination and shall deliver or send a copy of such determination to the Contractor, the ACCO, and Engineer, Resident Engineer, Engineering Audit Officer, or other designee of the Commissioner, as applicable, together with a statement concerning how the decision may be appealed.

27.4.3 Finality of Commissioner's Decision. The Commissioner's decision shall be final and binding on all parties, unless presented to the Contract Dispute Resolution Board pursuant to this Article 27. The City may not take a petition to the Contract Dispute Resolution Board. However, should the Contractor take such a petition, the City may seek, and the Contract Dispute Resolution Board may render, a determination less favorable to the Contractor and more favorable to the City than the decision of the Commissioner.

27.5 Presentation of Dispute to the Comptroller. Before any dispute may be brought by the Contractor to the Contract Dispute Resolution Board, the Contractor must first present its claim to the Comptroller for his or her review, investigation, and possible adjustment.

27.5.1 Time, Form, and Content of Notice. Within thirty (30) Days of its receipt of a decision by the Commissioner, the Contractor shall submit to the Comptroller and to the Commissioner a Notice of Claim regarding its dispute with the Agency. The Notice of Claim shall consist of (i) a brief written statement of the substance of the dispute, the amount of money, if any, claimed and the reason(s) the Contractor contends the dispute was wrongly decided by the Commissioner; (ii) a copy of the written decision of the Commissioner; and (iii) a copy of all materials submitted by the Contractor to the Agency, including the Notice of Dispute. The Contractor may not present to the Comptroller any material not presented to the Commissioner, except at the request of the Comptroller.

27.5.2 Response. Within thirty (30) Days of receipt of the Notice of Claim, the Agency shall make available to the Comptroller a copy of all material submitted by the Agency to the Commissioner in connection with the dispute. The Agency may not present to the Comptroller any material not presented to the Commissioner except at the request of the Comptroller.

27.5.3 Comptroller Investigation. The Comptroller may investigate the claim in dispute and, in the course of such investigation, may exercise all powers provided in Sections 7-201 and 7-203 of the Administrative Code. In addition, the Comptroller may demand of either party, and such party shall provide, whatever additional material the Comptroller deems pertinent to the claim, including original business records of the Contractor. Willful failure of the Contractor to produce within fifteen (15) Days any material requested by the Comptroller shall constitute a waiver by the Contractor of its claim. The Comptroller may also schedule an informal conference to be attended by the Contractor, Agency representatives, and any other personnel desired by the Comptroller.

27.5.4 Opportunity of Comptroller to Compromise or Adjust Claim. The Comptroller shall have forty-five (45) Days from his or her receipt of all materials referred to in Article 27.5.3 to investigate the disputed claim. The period for investigation and compromise may be further extended by agreement between the Contractor and the Comptroller, to a maximum of ninety (90) Days from the Comptroller's receipt of all materials. The Contractor may not present its petition to the Contract Dispute Resolution Board until the period for investigation and compromise delineated in this Article 27.5.4 has expired. In compromising or adjusting any claim hereunder, the Comptroller may not revise or disregard the terms of the Contract between the parties.

27.6 Contract Dispute Resolution Board. There shall be a Contract Dispute Resolution Board composed of:

27.6.1 The chief administrative law judge of the Office of Administrative Trials and Hearings (OATH) or his/her designated OATH administrative law judge, who shall act as chairperson, and may adopt operational procedures and issue such orders consistent with this Article 27 as may be necessary in the execution of the Contract Dispute Resolution Board's functions, including, but not limited to, granting extensions of time to present or respond to submissions;

27.6.2 The CCPO or his/her designee; any designee shall have the requisite background to consider and resolve the merits of the dispute and shall not have participated personally and substantially in the particular matter that is the subject of the dispute or report to anyone who so participated; and

27.6.3 A person with appropriate expertise who is not an employee of the City. This person shall be selected by the presiding administrative law judge from a prequalified panel of individuals, established and administered by OATH with appropriate background to act as decision-makers in a dispute. Such individual may not have a contract or dispute with the City or be an officer or employee of any company or organization that does, or regularly represents persons, companies, or organizations having disputes with the City.

27.7 Petition to the Contract Dispute Resolution Board. In the event the claim has not been settled or adjusted by the Comptroller within the period provided in this Article 27, the Contractor,

within thirty (30) Days thereafter, may petition the Contract Dispute Resolution Board to review the Commissioner's determination.

27.7.1 Form and Content of Petition by Contractor. The Contractor shall present its dispute to the Contract Dispute Resolution Board in the form of a petition, which shall include (i) a brief written statement of the substance of the dispute, the amount of money, if any, claimed, and the reason(s) the Contractor contends the dispute was wrongly decided by the Commissioner; (ii) a copy of the written Decision of the Commissioner; (iii) copies of all materials submitted by the Contractor to the Agency; (iv) a copy of the written decision of the Comptroller, if any, and (v) copies of all correspondence with, or written material submitted by the Contractor, to the Comptroller. The Contractor shall concurrently submit four (4) complete sets of the Petition: one set to the City Corporation Counsel (Attn: Commercial and Real Estate Litigation Division) and three (3) sets to the Contract Dispute Resolution Board at OATH's offices with proof of service on the City Corporation Counsel. In addition, the Contractor shall submit a copy of the written statement of the substance of the dispute, cited in (i) above, to both the Commissioner and the Comptroller.

27.7.2 Agency Response. Within thirty (30) Days of its receipt of the Petition by the City Corporation Counsel, the Agency shall respond to the brief written statement of the Contractor and make available to the Contract Dispute Resolution Board all material it submitted to the Commissioner and Comptroller. Three (3) complete copies of the Agency response shall be provided to the Contract Dispute Resolution Board and one to the Contractor. Extensions of time for submittal of the Agency response shall be given as necessary upon a showing of good cause or, upon consent of the parties, for an initial period of up to thirty (30) Days.

27.7.3 Further Proceedings. The Contract Dispute Resolution Board shall permit the Contractor to present its case by submission of memoranda, briefs, and oral argument. The Contract Dispute Resolution Board shall also permit the Agency to present its case in response to the Contractor by submission of memoranda, briefs, and oral argument. If requested by the City Corporation Counsel, the Comptroller shall provide reasonable assistance in the preparation of the Agency's case. Neither the Contractor nor the Agency may support its case with any documentation or other material that was not considered by the Comptroller, unless requested by the Contract Dispute Resolution Board. The Contract Dispute Resolution Board, in its discretion, may seek such technical or other expert advice as it shall deem appropriate and may seek, on its own or upon application of a party, any such additional material from any party as it deems fit. The Contract Dispute Resolution Board, in its discretion, may combine more than one dispute between the parties for concurrent resolution.

27.7.4 Contract Dispute Resolution Board Determination. Within forty-five (45) Days of the conclusion of all written submissions and oral arguments, the Contract Dispute Resolution Board shall render a written decision resolving the dispute. In an unusually complex case, the Contract Dispute Resolution Board may render its decision in a longer period, not to exceed ninety (90) Days, and shall so advise the parties at the commencement of this period. The Contract Dispute Resolution Board's decision must be consistent with the terms of the Contract. Decisions of the Contract Dispute Resolution Board shall only resolve matters before the Contract Dispute Resolution Board and shall not have precedential effect with respect to matters not before the Contract Dispute Resolution Board.

27.7.5 Notification of Contract Dispute Resolution Board Decision. The Contract Dispute Resolution Board shall send a copy of its decision to the Contractor, the ACCO, the Engineer, the Comptroller, the City Corporation Counsel, the CCPO, and the PPB. A decision in favor of the Contractor shall be subject to the prompt payment provisions of the PPB Rules. The Required Payment Date shall be thirty (30) Days after the date the parties are formally notified of the Contract Dispute Resolution Board's decision.

27.7.6 Finality of Contract Dispute Resolution Board Decision. The Contract Dispute Resolution Board's decision shall be final and binding on all parties. Any party may seek review of the Contract Dispute Resolution Board's decision solely in the form of a challenge, filed within four (4) months of the date of the Contract Dispute Resolution Board's decision, in a court of competent jurisdiction of the State of New York, County of New York pursuant to Article 78 of the Civil Practice Law and Rules. Such review by the court shall be limited to the question of whether or not the Contract Dispute Resolution Board's decision was made in violation of lawful procedure, was affected by an error of Law, or was arbitrary and capricious or an abuse of discretion. No evidence or information shall be introduced or relied upon in such proceeding that was not presented to the Contract Dispute Resolution Board in accordance with this Article 27.

27.8 Any termination, cancellation, or alleged breach of the Contract prior to or during the pendency of any proceedings pursuant to this Article 27 shall not affect or impair the ability of the Commissioner or Contract Dispute Resolution Board to make a binding and final decision pursuant to this Article 27.

ARTICLE 28. RECORD KEEPING FOR EXTRA OR DISPUTED WORK OR WORK ON A TIME & MATERIALS BASIS.

28.1 While the Contractor or any of its Subcontractors is performing Work on a time and material basis or Extra Work on a time and material basis ordered by the Commissioner under Article 25, or where the Contractor believes that it or any of its Subcontractors is performing Extra Work but a final determination by Agency has not been made, or the Contractor or any of its Subcontractors is performing disputed Work (whether on or off the Site), or complying with a determination or order under protest in accordance with Articles 11, 27, and 30, in each such case the Contractor shall furnish the Resident Engineer daily with three (3) copies of written statements signed by the Contractor's representative at the Site showing:

28.1.1 The name, trade, and number of each worker employed on such Work or engaged in complying with such determination or order, the number of hours employed, and the character of the Work each is doing; and

28.1.2 The nature and quantity of any materials, plant and equipment furnished or used in connection with the performance of such Work or compliance with such determination or order, and from whom purchased or rented.

28.2 A copy of such statement will be countersigned by the Resident Engineer, noting thereon any items not agreed to or questioned, and will be returned to the Contractor within two (2) Days after submission.

28.3 The Contractor and its Subcontractors, when required by the Commissioner, or the Comptroller, shall also produce for inspection, at the office of the Contractor or Subcontractor, any and all of its books, bid documents, financial statements, vouchers, records, daily job diaries and reports,

and cancelled checks, and any other documents relating to showing the nature and quantity of the labor, materials, plant and equipment actually used in the performance of such Work, or in complying with such determination or order, and the amounts expended therefor, and shall permit the Commissioner and the Comptroller to make such extracts therefrom, or copies thereof, as they or either of them may desire.

28.4 In connection with the examination provided for herein, the Commissioner, upon demand therefor, will produce for inspection by the Contractor such records as the Agency may have with respect to such Extra Work or disputed Work performed under protest pursuant to order of the Commissioner, except those records and reports which may have been prepared for the purpose of determining the accuracy and validity of the Contractor's claim.

28.5 Failure to comply strictly with these requirements shall constitute a waiver of any claim for extra compensation or damages on account of the performance of such Work or compliance with such determination or order.

ARTICLE 29. OMITTED WORK

29.1 If any Contract Work in a lump sum Contract, or if any part of a lump sum item in a unit price, lump sum, or percentage-bid Contract is omitted by the Commissioner pursuant to Article 33, the Contract price, subject to audit by the EAO, shall be reduced by a pro rata portion of the lump sum bid amount based upon the percent of Work omitted subject to Article 29.4. For the purpose of determining the pro rata portion of the lump sum bid amount, the bid breakdown submitted in accordance with Article 41 shall be considered; but shall not be the determining factor.

29.2 If the whole of a lump sum item or units of any other item is so omitted by the Commissioner in a unit price, lump sum, or percentage-bid Contract, then no payment will be made therefor except as provided in Article 29.4.

29.3 For units that have been ordered but are only partially completed, the unit price shall be reduced by a pro rata portion of the unit price bid based upon the percentage of Work omitted subject to Article 29.4.

29.4 In the event the Contractor, with respect to any omitted Work, has purchased any non-cancelable material and/or equipment that is not capable of use except in the performance of this Contract and has been specifically fabricated for the sole purpose of this Contract, but not yet incorporated into the Work, the Contractor shall be paid for such material and/or equipment in accordance with Article 64.2.1(b); provided, however, such payment is contingent upon the Contractor's delivery of such material and/or equipment in acceptable condition to a location designated by the City.

29.5 The Contractor agrees to make no claim for damages or for loss of overhead and profit with regard to any omitted Work.

ARTICLE 30. NOTICE AND DOCUMENTATION OF COSTS AND DAMAGES; PRODUCTION OF FINANCIAL RECORDS

30.1 If the Contractor shall claim to be sustaining damages by reason of any act or omission of the City or its agents, it shall submit to the Commissioner within forty-five (45) Days from the time such damages are first incurred, and every thirty (30) Days thereafter to the extent additional damages are being incurred for the same condition, verified statements of the details and the amounts of such

damages, together with documentary evidence of such damages. The Contractor may submit any of the above statements within such additional time as may be granted by the Commissioner in writing upon written request therefor. Failure of the Commissioner to respond in writing to a written request for additional time within thirty (30) Days shall be deemed a denial of the request. On failure of the Contractor to strictly comply with the foregoing provisions, such claims shall be deemed waived and no right to recover on such claims shall exist. Damages that the Contractor may claim in any action or dispute resolution procedure arising under or by reason of this Contract shall not be different from or in excess of the statements and documentation made pursuant to this Article 30. This Article 30.1 does not apply to claims submitted to the Commissioner pursuant to Article 11 or to claims disputing a determination under Article 27.

30.2 In addition to the foregoing statements, the Contractor shall, upon notice from the Commissioner, produce for examination at the Contractor's office, by the Engineer, Architect or Project Manager, all of its books of account, bills, invoices, payrolls, subcontracts, time books, daily reports, bank deposit books, bank statements, check books, and cancelled checks, showing all of its acts and transactions in connection with or relating to or arising by reason of this Contract, and submit itself and persons in its employment, for examination under oath by any person designated by the Commissioner or Comptroller to investigate claims made or disputes against the City under this Contract. At such examination, a duly authorized representative of the Contractor may be present.

30.3 In addition to the statements required under Article 28 and this Article 30, the Contractor and/or its Subcontractor shall, within thirty (30) Days upon notice from the Commissioner or Comptroller, produce for examination at the Contractor's and/or Subcontractor's office, by a representative of either the Commissioner or Comptroller, all of its books of account, bid documents, financial statements, accountant workpapers, bills, invoices, payrolls, subcontracts, time books, daily reports, bank deposit books, bank statements, check books, and cancelled checks, showing all of its acts and transactions in connection with or relating to or arising by reason of this Contract. Further, the Contractor and/or its Subcontractor shall submit any person in its employment, for examination under oath by any person designated by the Commissioner or Comptroller to investigate claims made or disputes against the City under this Contract. At such examination, a duly authorized representative of the Contractor may be present.

30.4 Unless the information and examination required under Article 30.3 is provided by the Contractor and/or its Subcontractor upon thirty (30) Days' notice from the Commissioner or Comptroller, or upon the Commissioner's or Comptroller's written authorization to extend the time to comply, the City shall be released from all claims arising under, relating to or by reason of this Contract, except for sums certified by the Commissioner to be due under the provisions of this Contract. It is further stipulated and agreed that no person has the power to waive any of the foregoing provisions and that in any action or dispute resolution procedure against the City to recover any sum in excess of the sums certified by the Commissioner to be due under or by reason of this Contract, the Contractor must allege in its complaint and prove, at trial or during such dispute resolution procedure, compliance with the provisions of this Article 30.

30.5 In addition, after the commencement of any action or dispute resolution procedure by the Contractor arising under or by reason of this Contract, the City shall have the right to require the Contractor to produce for examination under oath, up until the trial of the action or hearing before the Contract Dispute Resolution Board, the books and documents described in Article 30.3 and submit itself and all persons in its employ for examination under oath. If this Article 30 is not complied with as required, then the Contractor hereby consents to the dismissal of the action or dispute resolution procedure.

CHAPTER VII: POWERS OF THE RESIDENT ENGINEER, THE ENGINEER OR ARCHITECT AND THE COMMISSIONER

ARTICLE 31. THE RESIDENT ENGINEER

31.1 The Resident Engineer shall have the power to inspect, supervise, and control the performance of the Work, subject to review by the Commissioner. The Resident Engineer shall not, however, have the power to issue an Extra Work order, except as specifically designated in writing by the Commissioner.

ARTICLE 32. THE ENGINEER OR ARCHITECT OR PROJECT MANAGER

32.1 The Engineer or Architect or Project Manager, in addition to those matters elsewhere herein delegated to the Engineer and expressly made subject to his/her determination, direction or approval, shall have the power, subject to review by the Commissioner:

32.1.1 To determine the amount, quality, and location of the Work to be paid for hereunder; and

32.1.2 To determine all questions in relation to the Work, to interpret the Contract Drawings, Specifications, and Addenda, and to resolve all patent inconsistencies or ambiguities therein; and

32.1.3 To determine how the Work of this Contract shall be coordinated with Work of Other Contractors engaged simultaneously on this Project, including the power to suspend any part of the Work, but not the whole thereof; and

32.1.4 To make minor changes in the Work as he/she deems necessary, provided such changes do not result in a net change in the cost to the City or to the Contractor of the Work to be done under the Contract; and

32.1.5 To amplify the Contract Drawings, add explanatory information and furnish additional Specifications and drawings, consistent with this Contract.

32.2 The foregoing enumeration shall not imply any limitation upon the power of the Engineer or Architect or Project Manager, for it is the intent of this Contract that all of the Work shall generally be subject to his/her determination, direction, and approval, except where the determination, direction or approval of someone other than the Engineer or Architect or Project Manager is expressly called for herein.

32.3 The Engineer or Architect or Project Manager shall not, however, have the power to issue an Extra Work order, except as specifically designated in writing by the Commissioner.

ARTICLE 33. THE COMMISSIONER

33.1 The Commissioner, in addition to those matters elsewhere herein expressly made subject to his/her determination, direction or approval, shall have the power:

33.1.1 To review and make determinations on any and all questions in relation to this Contract and its performance; and

33.1.2 To modify or change this Contract so as to require the performance of Extra Work (subject, however, to the limitations specified in Article 25) or the omission of Contract Work; and

33.1.3 To suspend the whole or any part of the Work whenever in his/her judgment such suspension is required:

33.1.3(a) In the interest of the City generally; or

33.1.3(b) To coordinate the Work of the various contractors engaged on this Project pursuant to the provisions of Article 12; or

33.1.3(c) To expedite the completion of the entire Project even though the completion of this particular Contract may thereby be delayed.

ARTICLE 34. NO ESTOPPEL

34.1 Neither the City nor any Agency, official, agent or employee thereof, shall be bound, precluded or estopped by any determination, decision, approval, order, letter, payment or certificate made or given under or in connection with this Contract by the City, the Commissioner, the Engineer, the Resident Engineer, or any other official, agent or employee of the City, either before or after the final completion and acceptance of the Work and payment therefor:

34.1.1 From showing the true and correct classification, amount, quality or character of the Work actually done; or that any such determination, decision, order, letter, payment or certificate was untrue, incorrect or improperly made in any particular, or that the Work, or any part thereof, does not in fact conform to the requirements of this Contract; and

34.1.2 From demanding and recovering from the Contractor any overpayment made to it, or such damages as the City may sustain by reason of the Contractor's failure to perform each and every part of its Contract.

CHAPTER VIII: LABOR PROVISIONS

ARTICLE 35. EMPLOYEES

35.1 The Contractor and its Subcontractors shall not employ on the Work:

35.1.1 Anyone who is not competent, faithful and skilled in the Work for which he/she shall be employed; and whenever the Commissioner shall inform the Contractor, in writing, that any employee is, in his/her opinion, incompetent, unfaithful or disobedient, that employee shall be discharged from the Work forthwith, and shall not again be employed upon it; or

35.1.2 Any labor, materials or means whose employment, or utilization during the course of this Contract, may tend to or in any way cause or result in strikes, work stoppages, delays, suspension of Work or similar troubles by workers employed by the Contractor or its Subcontractors, or by any of the trades working in or about the buildings and premises where Work is being performed under this Contract, or by Other Contractors or their Subcontractors pursuant to other contracts, or on any other building or premises owned or operated by the City, its Agencies, departments, boards or authorities. Any violation by the Contractor of this requirement may, upon certification of the Commissioner, be considered as proper and sufficient cause for declaring the Contractor to be in default, and for the City to take action against it as set forth in Chapter X of this Contract, or such other article of this Contract as the Commissioner may deem proper; or

35.1.3 In accordance with Section 220.3-e of the Labor Law of the State of New York (hereinafter "Labor Law"), the Contractor and its Subcontractors shall not employ on the Work any apprentice, unless he/she is a registered individual, under a bona fide program registered with the New York State Department of Labor. The allowable ratio of apprentices to journey-level workers in any craft classification shall not be greater than the ratio permitted to the Contractor as to its work force on any job under the registered program. Any employee listed on a payroll at an apprentice wage rate, who is not registered as above, shall be paid the wage rate determined by the Comptroller of the City for the classification of Work actually performed. The Contractor or Subcontractor will be required to furnish written evidence of the registration of its program and apprentices as well as all the appropriate ratios and wage rates, for the area of the construction prior to using any apprentices on the Contract Work.

35.2 If the total cost of the Work under this Contract is at least two hundred fifty thousand (\$250,000) dollars, all laborers, workers, and mechanics employed in the performance of the Contract on the public work site, either by the Contractor, Subcontractor or other person doing or contracting to do the whole or a part of the Work contemplated by the Contract, shall be certified prior to performing any Work as having successfully completed a course in construction safety and health approved by the United States Department of Labor's Occupational Safety and Health Administration that is at least ten (10) hours in duration.

35.3 In accordance with Local Law Nos. 30-2012 and 33-2012, codified at sections 6-132 and 12-113 of the Administrative Code, respectively,

35.3.1 The Contractor shall not take an adverse personnel action with respect to an officer or employee in retaliation for such officer or employee making a report of information concerning conduct which such officer or employee knows or reasonably believes to involve corruption, criminal activity, conflict of interest, gross mismanagement or abuse of authority by any officer or employee relating to this Contract to (a) the Commissioner of the Department of Investigation, (b) a member of the New York City Council, the Public Advocate, or the Comptroller, or (c) the CCPO, ACCO, Agency head, or Commissioner.

35.3.2 If any of the Contractor's officers or employees believes that he or she has been the subject of an adverse personnel action in violation of Article 35.3.1, he or she shall be entitled to bring a cause of action against the Contractor to recover all relief necessary to make him or her whole. Such relief may include but is not limited to: (a) an injunction to restrain continued retaliation, (b) reinstatement to the position such employee would have had but for the retaliation or to an equivalent position, (c) reinstatement of full fringe benefits and seniority rights, (d) payment of two times back

pay, plus interest; and (e) compensation for any special damages sustained as a result of the retaliation, including litigation costs and reasonable attorney's fees.

35.3.3 The Contractor shall post a notice provided by the City in a prominent and accessible place on any site where work pursuant to the Contract is performed that contains information about:

35.3.3(a) how its employees can report to the New York City Department of Investigation allegations of fraud, false claims, criminality or corruption arising out of or in connection with the Contract; and

35.3.3(b) the rights and remedies afforded to its employees under Administrative Code sections 7-805 (the New York City False Claims Act) and 12-113 (the Whistleblower Protection Expansion Act) for lawful acts taken in connection with the reporting of allegations of fraud, false claims, criminality or corruption in connection with the Contract.

35.3.4 For the purposes of this Article 35.3, "adverse personnel action" includes dismissal, demotion, suspension, disciplinary action, negative performance evaluation, any action resulting in loss of staff, office space, equipment or other benefit, failure to appoint, failure to promote, or any transfer or assignment or failure to transfer or assign against the wishes of the affected officer or employee.

35.3.5 This Article 35.3 is applicable to all of the Contractor's Subcontractors having subcontracts with a value in excess of \$100,000; accordingly, the Contractor shall include this rider in all subcontracts with a value a value in excess of \$100,000.

35.4 Article 35.3 is not applicable to this Contract if it is valued at \$100,000 or less. Articles 35.3.1, 35.3.2, 35.3.4, and 35.3.5 are not applicable to this Contract if it was solicited pursuant to a finding of an emergency.

35.5 Paid Sick Leave Law.

35.5.1 Introduction and General Provisions.

35.5.1(a) The Earned Sick Time Act, also known as the Paid Sick Leave Law ("PSLL"); requires covered employees who annually perform more than 80 hours of work in New York City to be provided with paid sick time.² Contractors of the City or of other governmental entities may be required to provide sick time pursuant to the PSLL.

35.5.1(b) The PSLL became effective on April 1, 2014, and is codified at Title 20, Chapter 8, of the New York City Administrative Code. It is administered by the City's Department of Consumer Affairs ("DCA"); DCA's rules promulgated under the PSLL are codified at Chapter 7 of Title 6 of the Rules of the City of New York ("Rules").

² Pursuant to the PSLL, if fewer than five employees work for the same employer, as determined pursuant to New York City Administrative Code § 20-912(g), such employer has the option of providing such employees uncompensated sick time.

35.5.1(c) The Contractor agrees to comply in all respects with the PSL and the Rules, and as amended, if applicable, in the performance of this Contract. The Contractor further acknowledges that such compliance is a material term of this Contract and that failure to comply with the PSL in performance of this Contract may result in its termination.

35.5.1(d) The Contractor must notify the Agency Chief Contracting Officer of the Agency with whom it is contracting in writing within ten (10) days of receipt of a complaint (whether oral or written) regarding the PSL involving the performance of this Contract. Additionally, the Contractor must cooperate with DCA's education efforts and must comply with DCA's subpoenas and other document demands as set forth in the PSL and Rules.

35.5.1(e) The PSL is summarized below for the convenience of the Contractor. The Contractor is advised to review the PSL and Rules in their entirety. On the website www.nyc.gov/PaidSickLeave there are links to the PSL and the associated Rules as well as additional resources for employers, such as Frequently Asked Questions, timekeeping tools and model forms, and an event calendar of upcoming presentations and webinars at which the Contractor can get more information about how to comply with the PSL. The Contractor acknowledges that it is responsible for compliance with the PSL notwithstanding any inconsistent language contained herein.

35.5.2 Pursuant to the PSL and the Rules: Applicability, Accrual, and Use.

35.5.2(a) An employee who works within the City of New York for more than eighty hours in any consecutive 12-month period designated by the employer as its "calendar year" pursuant to the PSL ("Year") must be provided sick time. Employers must provide a minimum of one hour of sick time for every 30 hours worked by an employee and compensation for such sick time must be provided at the greater of the employee's regular hourly rate or the minimum wage. Employers are not required to provide more than 40 hours of sick time to an employee in any Year.

35.5.2(b) An employee has the right to determine how much sick time he or she will use, provided that employers may set a reasonable minimum increment for the use of sick time not to exceed four hours per Day. In addition, an employee may carry over up to 40 hours of unused sick time to the following Year, provided that no employer is required to allow the use of more than forty hours of sick time in a Year or carry over unused paid sick time if the employee is paid for such unused sick time and the employer provides the employee with at least the legally required amount of paid sick time for such employee for the immediately subsequent Year on the first Day of such Year.

35.5.2(c) An employee entitled to sick time pursuant to the PSL may use sick time for any of the following:

- i. such employee's mental illness, physical illness, injury, or health condition or the care of such illness, injury, or condition or such employee's need for medical diagnosis or preventive medical care;
- ii. such employee's care of a family member (an employee's child, spouse, domestic partner, parent, sibling, grandchild or grandparent, or the child or parent of an employee's spouse or domestic partner) who has a mental

- illness, physical illness, injury or health condition or who has a need for medical diagnosis or preventive medical care;
- iii. closure of such employee's place of business by order of a public official due to a public health emergency; or
 - iv. such employee's need to care for a child whose school or childcare provider has been closed due to a public health emergency.

35.5.2(d) An employer must not require an employee, as a condition of taking sick time, to search for a replacement. However, an employer may require an employee to provide: reasonable notice of the need to use sick time; reasonable documentation that the use of sick time was needed for a reason above if for an absence of more than three consecutive work days; and/or written confirmation that an employee used sick time pursuant to the PSLL. However, an employer may not require documentation specifying the nature of a medical condition or otherwise require disclosure of the details of a medical condition as a condition of providing sick time and health information obtained solely due to an employee's use of sick time pursuant to the PSLL must be treated by the employer as confidential.

35.5.2(e) If an employer chooses to impose any permissible discretionary requirement as a condition of using sick time, it must provide to all employees a written policy containing those requirements, using a delivery method that reasonably ensures that employees receive the policy. If such employer has not provided its written policy, it may not deny sick time to an employee because of non-compliance with such a policy.

35.5.2(f) Sick time to which an employee is entitled must be paid no later than the payday for the next regular payroll period beginning after the sick time was used.

35.5.3 Exemptions and Exceptions. Notwithstanding the above, the PSLL does not apply to any of the following:

35.5.3(a) an independent contractor who does not meet the definition of employee under section 190(2) of the New York State Labor Law;

35.5.3(b) an employee covered by a valid collective bargaining agreement in effect on April 1, 2014, until the termination of such agreement;

35.5.3(c) an employee in the construction or grocery industry covered by a valid collective bargaining agreement if the provisions of the PSLL are expressly waived in such collective bargaining agreement;

35.5.3(d) an employee covered by another valid collective bargaining agreement if such provisions are expressly waived in such agreement and such agreement provides a benefit comparable to that provided by the PSLL for such employee;

35.5.3(e) an audiologist, occupational therapist, physical therapist, or speech language pathologist who is licensed by the New York State Department of Education and who calls in for work assignments at will, determines his or her own schedule, has the ability to reject or accept any assignment referred to him or her, and is paid an average hourly wage that is at least four times the federal minimum wage;

35.5.3(f) an employee in a work study program under Section 2753 of Chapter 42 of the United States Code;

35.5.3(g) an employee whose work is compensated by a qualified scholarship program as that term is defined in the Internal Revenue Code, Section 117 of Chapter 20 of the United States Code; or

35.5.3(h) a participant in a Work Experience Program (WEP) under section 336-c of the New York State Social Services Law.

35.5.4 Retaliation Prohibited. An employer may not threaten or engage in retaliation against an employee for exercising or attempting in good faith to exercise any right provided by the PSL. In addition, an employer may not interfere with any investigation, proceeding, or hearing pursuant to the PSL.

35.5.5 Notice of Rights.

35.5.5(a) An employer must provide its employees with written notice of their rights pursuant to the PSL. Such notice must be in English and the primary language spoken by an employee, provided that DCA has made available a translation into such language. Downloadable notices are available on DCA's website at <http://www.nyc.gov/html/dca/html/law/PaidSickLeave.shtml>.

35.5.5(b) Any person or entity that willfully violates these notice requirements is subject to a civil penalty in an amount not to exceed fifty dollars for each employee who was not given appropriate notice.

35.5.6 Records. An employer must retain records documenting its compliance with the PSL for a period of at least three years, and must allow DCA to access such records in furtherance of an investigation related to an alleged violation of the PSL.

35.5.7 Enforcement and Penalties.

35.5.7(a) Upon receiving a complaint alleging a violation of the PSL, DCA has the right to investigate such complaint and attempt to resolve it through mediation. Within 30 Days of written notification of a complaint by DCA, or sooner in certain circumstances, the employer must provide DCA with a written response and such other information as DCA may request. If DCA believes that a violation of the PSL has occurred, it has the right to issue a notice of violation to the employer.

35.5.7(b) DCA has the power to grant an employee or former employee all appropriate relief as set forth in New York City Administrative Code § 20-924(d). Such relief may include, among other remedies, treble damages for the wages that should have been paid, damages for unlawful retaliation, and damages and reinstatement for unlawful discharge. In addition, DCA may impose on an employer found to have violated the PSL civil penalties not to exceed \$500 for a first violation, \$750 for a second violation within two years of the first violation, and \$1,000 for each succeeding violation within two years of the previous violation.

35.5.8 More Generous Policies and Other Legal Requirements. Nothing in the PSL is intended to discourage, prohibit, diminish, or impair the adoption or retention of a more generous sick time policy, or the obligation of an employer to comply with any contract,

collective bargaining agreement, employment benefit plan or other agreement providing more generous sick time. The PSLL provides minimum requirements pertaining to sick time and does not preempt, limit or otherwise affect the applicability of any other law, regulation, rule, requirement, policy or standard that provides for greater accrual or use by employees of sick leave or time, whether paid or unpaid, or that extends other protections to employees. The PSLL may not be construed as creating or imposing any requirement in conflict with any federal or state law, rule or regulation.

35.6 HireNYC: Hiring and Reporting Requirements. This Article 35.6 applies to construction contracts of \$1,000,000 or more. The Contractor shall comply with the requirements of Articles 35.6.1-35.6.5 for all non-trades jobs (e.g., for an administrative position arising out of Work and located in New York City). The Contractor shall reasonably cooperate with SBS and the City on specific outreach events, including "Hire-on-the-Spot" events, for the hiring of trades workers in connection with the Work. If provided elsewhere in this Contract, this Contract is subject to a project labor agreement.

35.6.1 Enrollment. The Contractor shall enroll with the HireNYC system, found at www.nyc.gov/sbs, within thirty (30) days after the registration of this Contract pursuant to Section 328 of the New York City Charter. The Contractor shall provide information about the business, designate a primary contact and say whether it intends to hire for any entry to mid-level job opportunities arising from this Contract and located in New York City, and, if so, the approximate start date of the first hire.

35.6.2 Job Posting Requirements.

35.6.2(a) Once enrolled in HireNYC, the Contractor agrees to update the HireNYC portal with all entry to mid-level job opportunities arising from this Contract and located in New York City, if any, which shall be defined as jobs requiring no more than an associate degree, as provided by the New York State Department of Labor (see Column F of <https://labor.ny.gov/stats/2012-2022-NYS-Employment-Prospects.xls>). The information to be updated includes the types of entry and mid-level positions made available from the work arising from the Contract and located in New York City, the number of positions, the anticipated schedule of initiating the hiring process for these positions, and the contact information for the Contractor's representative charged with overseeing hiring. The Contractor must update the HireNYC portal with any hiring needs arising from the contract and located in New York City, and the requirements of the jobs to be filled, no less than three weeks prior to the intended first day of employment for each new position, except with the permission of SBS, not to be unreasonably withheld, and must also update the HireNYC portal as set forth below.

35.6.2(b) After enrollment through HireNYC and submission of relevant information, SBS will work with the Contractor to develop a recruitment plan which will outline the candidate screening process, and will provide clear instructions as to when, where, and how interviews will take place. HireNYC will screen applicants based on employer requirements and refer applicants whom it believes are qualified to the Contractor for interviews. The Contractor must interview referred applicants whom it believes are qualified.

35.6.2(c) After completing an interview of a candidate referred by HireNYC, the Contractor must provide feedback via the portal within twenty (20) business days to indicate which candidates were interviewed and hired, if any. In addition, the Contractor shall provide the start date of new hires, and additional information

reasonably related to such hires, within twenty (20) business days after the start date. In the event the Contractor does not have any job openings covered by this Rider in any given year, the Contractor shall be required to provide an annual update to HireNYC to that effect. For this purpose, the reporting year shall run from the date of the registration of the Contract pursuant to Charter section 328 and each anniversary date.

35.6.2(d) These requirements do not limit the Contractor's ability to assess the qualifications of prospective workers, and to make final hiring and retention decisions. No provision of this Article 35.6 shall be interpreted so as to require the Contractor to employ any particular worker.

35.6.2(e) In addition, the provisions of this Article 35.6 shall not apply to positions that the Contractor intends to fill with employees employed pursuant to the job retention provision of Section 22-505 of the Administrative Code of the City of New York. The Contractor shall not be required to report such openings with HireNYC. However, the Contractor shall enroll with the HireNYC system pursuant to Article 35.6.1, above, and, if such positions subsequently become open, then the remaining provisions of this Article 35.6 will apply.

35.6.3 Breach and Liquidated Damages. If the Contractor fails to comply with the terms of the Contract and this Article 35.6 (1) by not enrolling its business with HireNYC; (2) by not informing HireNYC, as required, of open positions; or (3) by failing to interview a qualified candidate, the Agency may assess liquidated damages in the amount of two-thousand five hundred dollars (\$2,500) per breach. For all other events of noncompliance with the terms of this Article 35.6, the Agency may assess liquidated damages in the amount of five hundred dollars (\$500) per breach. Furthermore, in the event the Contractor breaches the requirements of this Article 35.6 during the term of the Contract, the City may hold the Contractor in default of this Contract.

35.6.4 Audit Compliance. In addition to the auditing requirements set forth in other parts of the Contract, the Contractor shall permit SBS and the City to inspect any and all records concerning or relating to job openings or the hiring of individuals for work arising from the Contract and located in New York City. The Contractor shall permit an inspection within seven (7) business days of the request.

35.6.5 Other Reporting Requirements. The Contractor shall report to the City, on a monthly basis, all information reasonably requested by the City that is necessary for the City to comply with any reporting requirements imposed by Law, including any requirement that the City maintain a publicly accessible database. In addition, the Contractor agrees to comply with all reporting requirements imposed by Law, or as otherwise requested by the City.

35.6.6 Federal Hiring Requirements. If this Contract is federally funded (as indicated elsewhere in this Contract), the Contractor shall comply with all federal hiring requirements as may be set forth in this Contract, including, as applicable: (a) Section 3 of the HUD Act of 1968, which requires, to the greatest extent feasible, economic opportunities for 30 percent of new hires be given to low- and very low-income persons, particularly persons who are recipients of HUD assistance for housing and Executive Order 11246, which prohibits discrimination in employment due to race, color, religion, sex or national origin, and requires the implementation of goals for minority and female participation for work involving any construction trade.

ARTICLE 36. NO DISCRIMINATION

36.1 The Contractor specifically agrees, as required by Labor Law Section 220-e, as amended, that:

36.1.1 In the hiring of employees for the performance of Work under this Contract or any subcontract hereunder, neither the Contractor, Subcontractor, nor any person acting on behalf of such Contractor or Subcontractor, shall by reason of race, creed, color or national origin discriminate against any citizen of the State of New York who is qualified and available to perform the Work to which the employment relates;

36.1.2 Neither the Contractor, Subcontractor, nor any person on its behalf shall, in any manner, discriminate against or intimidate any employee hired for the performance of Work under this Contract on account of race, creed, color or national origin;

36.1.3 There may be deducted from the amount payable to the Contractor by the City under this Contract a penalty of fifty (\$50.00) dollars for each person for each Day during which such person was discriminated against or intimidated in violation of the provisions of this Contract; and

36.1.4 This Contract may be cancelled or terminated by the City and all moneys due or to become due hereunder may be forfeited, for a second or any subsequent violation of the terms or conditions of this Article 36.

36.1.5 This Article 36 covers all construction, alteration and repair of any public building or public work occurring in the State of New York and the manufacture, sale, and distribution of materials, equipment, and supplies to the extent that such operations are performed within the State of New York pursuant to this Contract.

36.2 The Contractor specifically agrees, as required by Section 6-108 of the Administrative Code, as amended, that:

36.2.1 It shall be unlawful for any person engaged in the construction, alteration or repair of buildings or engaged in the construction or repair of streets or highways pursuant to a Contract with the City or engaged in the manufacture, sale or distribution of materials, equipment or supplies pursuant to a Contract with the City to refuse to employ or to refuse to continue in any employment any person on account of the race, color or creed of such person.

36.2.2 It shall be unlawful for any person or any servant, agent or employee of any person, described in Article 36.1.2, to ask, indicate or transmit, orally or in writing, directly or indirectly, the race, color or creed or religious affiliation of any person employed or seeking employment from such person, firm or corporation.

36.2.3 Breach of the foregoing provisions shall be deemed a violation of a material provision of this Contract.

36.2.4 Any person, or the employee, manager or owner of or officer of such firm or corporation who shall violate any of the provisions of this Article 36.2 shall, upon

conviction thereof, be punished by a fine of not more than one hundred (\$100.00) dollars or by imprisonment for not more than thirty (30) Days, or both.

36.3 This Contract is subject to the requirements of Executive Order No. 50 (1980) ("E.O. 50"), as revised, and the rules and regulations promulgated thereunder. No contract will be awarded unless and until these requirements have been complied with in their entirety. By signing this Contract, the Contractor agrees that it:

36.3.1 Will not engage in any unlawful discrimination against any employee or applicant for employment because of race, creed, color, national origin, sex, age, disability, marital status or sexual orientation with respect to all employment decisions including, but not limited to, recruitment, hiring, upgrading, demotion, downgrading, transfer, training, rates of pay or other forms of compensation, layoff, termination, and all other terms and conditions of employment; and

36.3.2 Will not engage in any unlawful discrimination in the selection of Subcontractors on the basis of the owner's race, color, creed, national origin, sex, age, disability, marital status or sexual orientation; and

36.3.3 Will state in all solicitations or advertisements for employees placed by or on behalf of the Contractor that all qualified applicants will receive consideration for employment without unlawful discrimination based on race, creed, color, national origin, sex, age, citizens status, disability, marital status, sexual orientation, or that it is an equal employment opportunity employer; and

36.3.4 Will send to each labor organization or representative of workers with which it has a collective bargaining agreement or other contract or memorandum of understanding, written notification of its equal employment opportunity commitments under E.O. 50 and the rules and regulations promulgated thereunder; and

36.3.5 Will furnish, before the award of the Contract, all information and reports, including an employment report, that are required by E.O. 50, the rules and regulations promulgated thereunder, and orders of the City Department of Business Services, Division of Labor Services (DLS) and will permit access to its books, records, and accounts by the DLS for the purposes of investigation to ascertain compliance with such rules, regulations, and orders.

36.4 The Contractor understands that in the event of its noncompliance with the nondiscrimination clauses of this Contract or with any of such rules, regulations, or orders, such noncompliance shall constitute a material breach of this Contract and noncompliance with E.O. 50 and the rules and regulations promulgated thereunder. After a hearing held pursuant to the rules of the DLS, the Director of the DLS may direct the Commissioner to impose any or all of the following sanctions:

36.4.1 Disapproval of the Contractor; and/or

36.4.2 Suspension or termination of the Contract; and/or

36.4.3 Declaring the Contractor in default; and/or

36.4.4 In lieu of any of the foregoing sanctions, the Director of the DLS may impose an employment program.

In addition to any actions taken under this Contract, failure to comply with E.O. 50 and the rules and regulations promulgated thereunder, in one or more instances, may result in a City Agency declaring the Contractor to be non-responsible in future procurements. The Contractor further agrees that it will refrain from entering into any Contract or Contract modification subject to E.O. 50 and the rules and regulations promulgated thereunder with a Subcontractor who is not in compliance with the requirements of E.O. 50 and the rules and regulations promulgated thereunder.

36.5 The Contractor specifically agrees, as required by Section 6-123 of the Administrative Code, that:

36.5.1 The Contractor will not engage in any unlawful discriminatory practice in violation of Title 8 of the Administrative Code; and

36.5.2 Any failure to comply with this Article 36.5 may subject the Contractor to the remedies set forth in Section 6-123 of the Administrative Code, including, where appropriate, sanctions such as withholding of payment, imposition of an employment program, finding the Contractor to be in default, cancellation of the Contract, or any other sanction or remedy provided by Law or Contract.

ARTICLE 37. LABOR LAW REQUIREMENTS

37.1 The Contractor shall strictly comply with all applicable provisions of the Labor Law, as amended. Such compliance is a material term of this Contract.

37.2 The Contractor specifically agrees, as required by Labor Law Sections 220 and 220-d, as amended, that:

37.2.1 **Hours of Work:** No laborer, worker, or mechanic in the employ of the Contractor, Subcontractor or other person doing or contracting to do the whole or a part of the Work contemplated by this Contract shall be permitted or required to work more than eight (8) hours in any one (1) Day, or more than five (5) Days in any one (1) week, except as provided in the Labor Law and in cases of extraordinary emergency including fire, flood, or danger to life or property, or in the case of national emergency when so proclaimed by the President of the United States of America.

37.2.2 In situations in which there are not sufficient laborers, workers, and mechanics who may be employed to carry on expeditiously the Work contemplated by this Contract as a result of such restrictions upon the number of hours and Days of labor, and the immediate commencement or prosecution or completion without undue delay of the Work is necessary for the preservation of the Site and/or for the protection of the life and limb of the persons using the same, such laborers, workers, and mechanics shall be permitted or required to work more than eight (8) hours in any one (1) Day; or five (5) Days in any one (1) week; provided, however, that upon application of any Contractor, the Commissioner shall have first certified to the Commissioner of Labor of the State of New York (hereinafter "Commissioner of Labor") that such public Work is of an important nature and that a delay in carrying it to completion would result in serious disadvantage to the public; and provided, further, that such Commissioner of Labor shall have determined that such an emergency does in fact exist as provided in Labor Law Section 220.2.

37.2.3 Failure of the Commissioner to make such a certification to the Commissioner of Labor shall not entitle the Contractor to damages for delay or for any cause whatsoever.

37.2.4 Prevailing Rate of Wages: The wages to be paid for a legal day's Work to laborers, workers, or mechanics employed upon the Work contemplated by this Contract or upon any materials to be used thereon shall not be less than the "prevailing rate of wage" as defined in Labor Law Section 220, and as fixed by the Comptroller in the attached Schedule of Wage Rates and in updated schedules thereof. The prevailing wage rates and supplemental benefits to be paid are those in effect at the time the Work is being performed.

37.2.5 Requests for interpretation or correction in the Information for Bidders includes all requests for clarification of the classification of trades to be employed in the performance of the Work under this Contract. In the event that a trade not listed in the Contract is in fact employed during the performance of this Contract, the Contractor shall be required to obtain from the Agency the prevailing wage rates and supplementary benefits for the trades used and to complete the performance of this Contract at the price at which the Contract was awarded.

37.2.6 Minimum Wages: Except for employees whose wage is required to be fixed pursuant to Labor Law Section 220, all persons employed by the Contractor and any Subcontractor in the manufacture or furnishing of the supplies, materials, or equipment, or the furnishing of work, labor, or services, used in the performance of this Contract, shall be paid, without subsequent deduction or rebate unless expressly authorized by Law, not less than the sum mandated by Law.

37.3 Working Conditions: No part of the Work, labor or services shall be performed or rendered by the Contractor in any plants, factories, buildings or surroundings or under working conditions which are unsanitary or hazardous or dangerous to the health and safety of employees engaged in the performance of this Contract. Compliance with the safety, sanitary, and factory inspection Laws of the state in which the Work is to be performed shall be prima facie evidence of compliance with this Article 37.3.

37.4 Prevailing Wage Enforcement: The Contractor agrees to pay for all costs incurred by the City in enforcing prevailing wage requirements, including the cost of any investigation conducted by or on behalf of the Agency or the Comptroller, where the City discovers a failure to comply with any of the requirements of this Article 37 by the Contractor or its Subcontractor(s). The Contractor also agrees that, should it fail or refuse to pay for any such investigation, the Agency is hereby authorized to deduct from a Contractor's account an amount equal to the cost of such investigation.

37.4.1 The Labor Law Section 220 and Section 220-d, as amended, provide that this Contract shall be forfeited and no sum paid for any Work done hereunder on a second conviction for willfully paying less than:

37.4.1(a) The stipulated prevailing wage scale as provided in Labor Law section 220, as amended, or

37.4.1(b) The stipulated minimum hourly wage scale as provided in Labor Law section 220-d, as amended.

37.4.2 For any breach or violation of either working conditions (Article 37.3) or minimum wages (Article 37.2.6) provisions, the party responsible therefor shall be liable to the City for liquidated damages, which may be withheld from any amounts due on any contracts with the City of such party responsible, or may be recovered in actions brought by the City

Corporation Counsel in the name of the City, in addition to damages for any other breach of this Contract, for a sum equal to the amount of any underpayment of wages due to any employee engaged in the performance of this Contract. In addition, the Commissioner shall have the right to cancel contracts and enter into other contracts for the completion of the original contract, with or without public letting, and the original Contractor shall be liable for any additional cost. All sums withheld or recovered as deductions, rebates, refunds, or underpayment of wages hereunder, shall be held in a special deposit account and shall be paid without interest, on order of the Comptroller, directly to the employees who have been paid less than minimum rates of pay as set forth herein and on whose account such sums were withheld or recovered, provided that no claims by employees for such payments shall be entertained unless made within two (2) years from the date of actual notice to the Contractor of the withholding or recovery of such sums by the City.

37.4.3 A determination by the Comptroller that a Contractor and/or its Subcontractor willfully violated Labor Law Section 220 will be forwarded to the City's five District Attorneys for review.

37.4.4 The Contractor's or Subcontractor's noncompliance with this Article 37.4 and Labor Law Section 220 may result in an unsatisfactory performance evaluation and the Comptroller may also find and determine that the Contractor or Subcontractor willfully violated the New York Labor Law.

37.4.4(a) An unsatisfactory performance evaluation for noncompliance with this Article 37.4 may result in a determination that the Contractor is a non-responsible bidder on subsequent procurements with the City and thus a rejection of a future award of a contract with the City, as well as any other sanctions provided for by Law.

37.4.4(b) Labor Law Section 220-b, as amended, provides that when two (2) final determinations have been rendered against a Contractor or Subcontractor within any consecutive six (6) year period determining that such Contractor or Subcontractor has willfully failed to pay the prevailing rate of wages or to provide supplements in accordance with the Labor Law and this Article 37.4, whether such failures were concurrent or consecutive and whether or not such final determinations concerning separate public works projects are rendered simultaneously, such Contractor or Subcontractor shall be ineligible to submit a bid on or be awarded any public works contract with the City for a period of five (5) years from the second final determination. If the final determination involves the falsification of payroll records or the kickback of wages or supplements, the Contractor or Subcontractor shall be ineligible to submit a bid on or be awarded any public works contract with the City for a period of five (5) years from the first final determination.

37.4.4(c) Labor Law Section 220, as amended, provides that the Contractor or Subcontractor found to have violated this Article 37.4 may be directed to make payment of wages or supplements including interest found to be due, and the Contractor or Subcontractor may be directed to make payment of a further sum as a civil penalty in an amount not exceeding twenty-five (25%) percent of the total amount found to be due.

37.5 The Contractor and its Subcontractors shall within ten (10) Days after mailing of a Notice of Award or written order, post in prominent and conspicuous places in each and every plant, factory, building, and structure where employees of the Contractor and its Subcontractors engaged in the

performance of this Contract are employed, notices furnished by the City, in relation to prevailing wages and supplements, minimum wages, and other stipulations contained in Sections 220 and 220-h of the Labor Law, and the Contractor and its Subcontractors shall continue to keep such notices posted in such prominent and conspicuous places until Final Acceptance of the supplies, materials, equipment, or Work, labor, or services required to be furnished or rendered under this Contract.

37.6 The Contractor shall strictly comply with all of the provisions of Articles 37.6.1 through 37.6.5, and provide for all workers, laborers or mechanics in its employ, the following:

37.6.1 Notices Posted At Site: Post, in a location designated by the City, schedules of prevailing wages and supplements for this Project, a copy of all re-determinations of such schedules for the Project, the Workers' Compensation Law Section 51 notice, all other notices required by Law to be posted at the Site, the City notice that this Project is a public works project on which each worker is entitled to receive the prevailing wages and supplements for the occupation at which he or she is working, and all other notices which the City directs the Contractor to post. The Contractor shall provide a surface for such notices which is satisfactory to the City. The Contractor shall maintain and keep current such notices in a legible manner and shall replace any notice or schedule which is damaged, defaced, illegible or removed for any reason. The Contractor shall post such notices before commencing any Work on the Site and shall maintain such notices until all Work on the Site is complete; and

37.6.2 Daily Site Sign-in Sheets: Maintain daily Site sign-in sheets, and require that Subcontractors maintain daily Site sign-in sheets for its employees, which include blank spaces for an employee's name to be both printed and signed, job title, date started and Social Security number, the time the employee began work and the time the employee left work, until Final Acceptance of the supplies, materials, equipment, or Work, labor, or services to be furnished or rendered under this Contract unless exception is granted by the Comptroller upon application by the Agency. In the alternative, subject to the approval of the CCPO, the Contractor and Subcontractor may maintain an electronic or biometric sign-in system, which provides the information required by this Article 37.6.2; and

37.6.3 Individual Employee Information Notices: Distribute a notice to each worker, laborer or mechanic employed under this Contract; in a form provided by the Agency, that this Project is a public works project on which each worker, laborer or mechanic is entitled to receive the prevailing rate of wages and supplements for the occupation at which he or she is working. If the total cost of the Work under this Contract is at least two hundred fifty thousand (\$250,000) dollars, such notice shall also include a statement that each worker, laborer or mechanic must be certified prior to performing any Work as having successfully completed a course in construction safety and health approved by the United States Department of Labor's Occupational Safety and Health Administration that is at least ten (10) hours in duration. Such notice shall be distributed to each worker before he or she starts performing any Work of this Contract and with the first paycheck after July first of each year. "Worker, laborer or mechanic" includes employees of the Contractor and all Subcontractors and all employees of suppliers entering the Site. At the time of distribution, the Contractor shall have each worker, laborer or mechanic sign a statement, in a form provided by the Agency, certifying that the worker has received the notice required by this Article 37.6.3, which signed statement shall be maintained with the payroll records required by this Contract; and

37.6.3(a) The Contractor and each Subcontractor shall notify each worker, laborer or mechanic employed under this Contract in writing of the prevailing rate of

wages for their particular job classification. Such notification shall be given to every worker, laborer, and mechanic on their first pay stub and with every pay stub thereafter; and

37.6.4 Site Laminated Identification Badges: The Contractor shall provide laminated identification badges which include a photograph of the worker's, laborer's or mechanic's face and indicate the worker's, laborer's or mechanic's name, trade, employer's name, and employment starting date (month/day/year). Further, the Contractor shall require as a condition of employment on the Site, that each and every worker, laborer or mechanic wear the laminated identification badge at all times and that it may be seen by any representative of the City. The Commissioner may grant a written waiver from the requirement that the laminated identification badge include a photograph if the Contractor demonstrates that the identity of an individual wearing a laminated identification badge can be easily verified by another method; and

37.6.5 Language Other Than English Used On-Site: Provide the ACCO notice when three (3) or more employees (worker and/or laborer and/or mechanic) on the Site, at any time, speak a language other than English. The ACCO will then provide the Contractor the notices described in Article 37.6.1 in that language or languages as may be required. The Contractor is responsible for all distributions under this Article 37; and

37.6.6 Provision of Records: The Contractor and Subcontractor(s) shall produce within five (5) Days on the Site of the Work and upon a written order of the Engineer, the Commissioner, the ACCO, the Agency EAO, or the Comptroller, such records as are required to be kept by this Article 37.6; and

37.6.7 The Contractor and Subcontractor(s) shall pay employees by check or direct deposit. If this Contract is for an amount greater than one million (\$1,000,000) dollars, checks issued by the Contractor to covered employees shall be generated by a payroll service or automated payroll system (an in-house system may be used if approved by the Agency). For any subcontract for an amount greater than seven hundred fifty thousand (\$750,000) dollars, checks issued by a Subcontractor to covered employees shall be generated by a payroll service or automated payroll system (an in-house system may be used if approved by the Agency); and

37.6.8 The failure of the Contractor or Subcontractor(s) to comply with the provisions of Articles 37.6.1 through 37.6.7 may result in the Commissioner declaring the Contractor in default and/or the withholding of payments otherwise due under the Contract.

37.7 The Contractor and its Subcontractors shall keep such employment and payroll records as are required by Section 220 of the Labor Law. The failure of the Contractor or Subcontractor(s) to comply with the provisions of this Article 37.7 may result in the Commissioner declaring the Contractor in default and/or the withholding of payments otherwise due under the Contract.

37.8 At the time the Contractor makes application for each partial payment and for final payment, the Contractor shall submit to the Commissioner a written payroll certification, in the form provided by this Contract, of compliance with the prevailing wage, minimum wage, and other provisions and stipulations required by Labor Law Section 220 and of compliance with the training requirements of Labor Law Section 220-h set forth in Article 35.2. This certification of compliance shall be a condition precedent to payment and no payment shall be made to the Contractor unless and until each such certification shall have been submitted to and received by the Commissioner.

37.9 This Contract is executed by the Contractor with the express warranty and representation that the Contractor is not disqualified under the provisions of Section 220 of the Labor Law from the award of the Contract.

37.10 Any breach or violation of any of the foregoing shall be deemed a breach or violation of a material provision of this Contract, and grounds for cancellation thereof by the City.

ARTICLE 38. PAYROLL REPORTS

38.1 The Contractor and its Subcontractor(s) shall maintain on the Site during the performance of the Work the original payrolls or transcripts thereof which the Contractor and its Subcontractor(s) are required to maintain and shall submit such original payrolls or transcripts, subscribed and affirmed by it as true, within thirty (30) Days after issuance of its first payroll, and every thirty (30) Days thereafter, pursuant to Labor Law Section 220(3-a)(a)(iii). The Contractor and Subcontractor(s) shall submit such original payrolls or transcripts along with each and every payment requisition. If payment requisitions are not submitted at least once a month, the Contractor and its Subcontractor(s) shall submit original payrolls and transcripts both along with its payment requisitions and independently of its payment requisitions.

38.2 The Contractor shall maintain payrolls or transcripts thereof for six (6) years from the date of completion of the Work on this Contract. If such payrolls and transcripts are maintained outside of New York City after the completion of the Work and their production is required pursuant to this Article 38, the Contractor shall produce such records in New York City upon request by the City.

38.3 The Contractor and Subcontractor(s) shall comply with any written order, direction, or request made by the Engineer, the Commissioner, the ACCO, the Agency EAO, the Agency Labor Law Investigator(s), or the Comptroller, to provide to the requesting party any of the following information and/or records within five (5) Days of such written order, direction, or request:

38.3.1 Such original payrolls or transcripts thereof subscribed and affirmed by it as true and the statements signed by each worker pursuant to this Chapter VIII; and/or

38.3.2 Attendance sheets for each Day on which any employee of the Contractor and/or any of the Subcontractor(s) performed Work on the Site, which attendance sheet shall be in a form acceptable to the Agency and shall provide information acceptable to the Agency to identify each such employee; and/or

38.3.3 Any other information to satisfy the Engineer, the Commissioner, the ACCO, the Agency EAO, the Agency Labor Law Investigator(s) or the Comptroller, that this Chapter VIII and the Labor Law, as to the hours of employment and prevailing rates of wages and/or supplemental benefits, are being observed.

38.4 The failure of the Contractor or Subcontractor(s) to comply with the provisions of Articles 38.1 and/or 38.2 may result in the Commissioner declaring the Contractor in default and/or the withholding of payments otherwise due under the Contract.

ARTICLE 39. DUST HAZARDS

39.1 Should a harmful dust hazard be created in performing the Work of this Contract, for the elimination of which appliances or methods have been approved by the Board of Standards and Appeals

of the City of New York, such appliances and methods shall be installed, maintained, and effectively operated during the continuance of such harmful dust hazard. Failure to comply with this provision after notice shall make this Contract voidable at the sole discretion of the City.

CHAPTER IX: PARTIAL AND FINAL PAYMENTS

ARTICLE 40. CONTRACT PRICE

40.1 The City shall pay, and the Contractor agrees to accept, in full consideration for the Contractor's performance of the Work subject to the terms and conditions hereof, the lump sum price or unit prices for which this Contract was awarded, plus the amount required to be paid for any Extra Work ordered by the Commissioner under Article 25, less credit for any Work omitted pursuant to Article 29.

ARTICLE 41. BID BREAKDOWN ON LUMP SUM

41.1 Within fifteen (15) Days after the commencement date specified in the Notice to Proceed or Order to Work, unless otherwise directed by the Resident Engineer, the Contractor shall submit to the Resident Engineer a breakdown of its bid price, or of lump sums bid for items of the Contract, showing the various operations to be performed under the Contract, as directed in the progress schedule required under Article 9, and the value of each of such operations, the total of such items to equal the lump sum price bid. Said breakdown must be approved in writing by the Resident Engineer.

41.2 No partial payment will be approved until the Contractor submits a bid breakdown that is acceptable to the Resident Engineer.

41.3 The Contractor shall also submit such other information relating to the bid breakdown as directed by the Resident Engineer. Thereafter, the breakdown may be used only for checking the Contractor's applications for partial payments hereunder, but shall not be binding upon the City, the Commissioner, or the Engineer for any purpose whatsoever.

ARTICLE 42. PARTIAL PAYMENTS

42.1 From time to time as the Work progresses satisfactorily, but not more often than once each calendar month (except where the Commissioner approves in writing the submission of invoices on a more frequent basis and for invoices relating to Work performed pursuant to a change order), the Contractor may submit to the Engineer a requisition for a partial payment in the prescribed form, which shall contain an estimate of the quantity and the fair value of the Work done during the payment period.

42.2 Partial payments may be made for materials, fixtures, and equipment in advance of their actual incorporation in the Work, as the Commissioner may approve, and upon the terms and conditions set forth in the General Conditions.

42.3 The Contractor shall also submit to the Commissioner in connection with every application for partial payment a verified statement in the form prescribed by the Comptroller setting forth the information required under Labor Law Section 220-a.

42.4 Within thirty (30) Days after receipt of a satisfactory payment application, and within sixty (60) Days after receipt of a satisfactory payment application in relation to Work performed pursuant to a change order, the Engineer will prepare and certify, and the Commissioner will approve, a voucher for a partial payment in the amount of such approved estimate, less any and all deductions authorized to be made by the Commissioner under the terms of this Contract or by Law.

ARTICLE 43. PROMPT PAYMENT

43.1 The Prompt Payment provisions of the PPB Rules in effect at the time of the bid will be applicable to payments made under this Contract. The provisions require the payment to the Contractor of interest on payments made after the required payment date, except as set forth in the PPB Rules.

43.2 The Contractor shall submit a proper invoice to receive payment, except where the Contract provides that the Contractor will be paid at predetermined intervals without having to submit an invoice for each scheduled payment.

43.3 Determination of interest due will be made in accordance with the PPB Rules.

43.4 If the Contractor is paid interest, the proportionate share(s) of that interest shall be forwarded by the Contractor to its Subcontractor(s).

43.5 The Contractor shall pay each Subcontractor or Materialman not later than seven (7) Days after receipt of payment out of amounts paid to the Contractor by the City for Work performed by the Subcontractor or Materialman under this Contract.

43.5.1 If Contractor fails to make any payment to any Subcontractor or Materialman within seven (7) Days after receipt of payment by the City pursuant to this Article 43.5, then the Contractor shall pay interest on amounts due to such Subcontractor or Materialman at the rate of interest in effect on the date such payment is made by the Contractor computed in accordance with Section 756-b (1)(b) of the New York General Business Law. Accrual of interest shall commence on the Day immediately following the expiration of the seventh Day following receipt of payment by the Contractor from the City and shall end on the date on which payment is made.

43.6 The Contractor shall include in each of its subcontracts a provision requiring each Subcontractor to make payment to each of its Subcontractors or Materialmen for Work performed under this Contract in the same manner and within the same time period set forth above.

ARTICLE 44. SUBSTANTIAL COMPLETION PAYMENT

44.1 The Contractor shall submit with the Substantial Completion requisition:

44.1.1 A final verified statement of any pending Article 27 disputes in accordance with the PPB Rules and this Contract and any and all alleged claims against the City, in any way connected with or arising out of this Contract (including those as to which details may have been furnished pursuant to Articles 11, 27, 28, and 30) setting forth with respect to each such claim the total amount thereof, the various items of labor and materials included therein, and the alleged value of each item; and if the alleged claim be one for delay, the alleged cause of each such delay, the period or periods of time, giving the dates when the

Contractor claims the performance of the Work or a particular part thereof was delayed, and an itemized statement and breakdown of the amount claimed for each such delay.

44.1.1(a) With respect to each such claim, the Commissioner, the Comptroller and, in the event of litigation, the City Corporation Counsel shall have the same right to inspect, and to make extracts or copies of, the Contractor's books, vouchers, records, etc., as is referred to in Articles 11, 27, 28, and 30. Nothing contained in this Article 44.1.1(a) is intended to or shall relieve the Contractor from the obligation of complying strictly with Articles 11, 27, 28, and 30. The Contractor is warned that unless such claims are completely set forth as herein required, the Contractor upon acceptance of the Substantial Completion payment pursuant to this Article 44, will have waived any such claims.

44.1.2 A Final Approved Punch List.

44.1.3 Where required, a request for an extension of time to achieve Substantial Completion or final extension of time.

44.2 The Commissioner shall issue a voucher calling for payment of any part or all of the balance due for Work performed under the Contract, including monies retained under Article 21, less any and all deductions authorized to be made by the Commissioner, under this Contract or by Law, and less twice the amount the Commissioner considers necessary to ensure the completion of the balance of the Work by the Contractor. Such a payment shall be considered a partial and not a final payment. No Substantial Completion payment shall be made under this Article 44 where the Contractor failed to complete the Work within the time fixed for such completion in the Schedule A of the General Conditions; or within the time to which completion may have been extended, until an extension or extensions of time for the completion of Work have been acted upon pursuant to Article 13.

44.3 No further partial payments shall be made to the Contractor after Substantial Completion, except the Substantial Completion payment and payment pursuant to any Contractor's requisition that were properly filed with the Commissioner prior to the date of Substantial Completion; however, the Commissioner may grant a waiver for further partial payments after the date of Substantial Completion to permit payments for change order Work and/or release of retainage and deposits pursuant to Articles 21 and 24. Such waiver shall be in writing.

44.4 The Contractor acknowledges that nothing contained in this Article 44 is intended to or shall in any way diminish the force and effect of Article 13.

ARTICLE 45. FINAL PAYMENT

45.1 After completion and Final Acceptance of the Work, the Contractor shall submit all required certificates and documents, together with a requisition for the balance claimed to be due under the Contract, less the amount authorized to be retained for maintenance under Article 24. Such submission shall be within 90 days of the date of the Commissioner's written determination of Final Acceptance, or within such additional time as may be granted by the Commissioner in writing. If the Contractor fails to submit all required certificates and documents within the time allowed, no payment of the balance claimed shall be made to the Contractor and the Contractor shall be deemed to have forfeited its right to payment of any balance claimed. A verified statement similar to that required in connection with applications for partial payments shall also be submitted to the Commissioner.

45.2 Amended Verified Statement of Claims: The Contractor shall also submit with the final requisition any amendments to the final verified statement of any pending dispute resolution procedures in accordance with the PPB Rules and this Contract and any and all alleged claims against the City, in any way connected with or arising out of this Contract (including those as to which details may have been furnished pursuant to Articles 11, 27, 28, and 30) that have occurred subsequent to Substantial Completion, setting forth with respect to each such claim the total amount thereof, the various items of labor and materials included therein, and the alleged value of each such item; and if the alleged claim be one for delay, the alleged cause of each such delay, the period or periods of time, giving the dates when the Contractor claims the performance of the Work or a particular part thereof was delayed, and an itemized statement and breakdown of the amount claimed for each such delay. With reference to each such claim, the Commissioner, the Comptroller and, in the event of litigation, the City Corporation Counsel shall have the same right to inspect, and to make extracts or copies of, the Contractor's books, vouchers, records, etc., as is referred to in Articles 11, 27, 28, and 30. Nothing contained in this Article 45.2, is intended to or shall relieve the Contractor from the obligation of complying strictly with Articles 11, 27, 28, and 30. The Contractor is warned that unless such claims are completely set forth as herein required, the Contractor, upon acceptance of the Final Payment pursuant to Article 46, will have waived any such claims.

45.3 Preparation of Final Voucher: Upon determining the balance due hereunder other than on account of claims, the Engineer will prepare and certify, for the Commissioner's approval, a voucher for final payment in that amount less any and all deductions authorized to be made by the Commissioner under this Contract or by Law. In the case of a lump sum Contract, the Commissioner shall certify the voucher for final payment within thirty (30) Days from the date of completion and acceptance of the Work, provided all requests for extensions of time have been acted upon.

45.3.1 All prior certificates and vouchers upon which partial payments were made, being merely estimates made to enable the Contractor to prosecute the Work more advantageously, shall be subject to correction in the final voucher, and the certification of the Engineer thereon and the approval of the Commissioner thereof, shall be conditions precedent to the right of the Contractor to receive any money hereunder. Such final voucher shall be binding and conclusive upon the Contractor.

45.3.2 Payment pursuant to such final voucher, less any deductions authorized to be made by the Commissioner under this Contract or by Law, shall constitute the final payment, and shall be made by the Comptroller within thirty (30) Days after the filing of such voucher in his/her office.

45.4 The Contractor acknowledges that nothing contained in this Article 45 is intended to or shall in any way diminish the force and effect of Article 13.

ARTICLE 46. ACCEPTANCE OF FINAL PAYMENT

46.1 The acceptance by the Contractor, or by anyone claiming by or through it, of the final payment, whether such payment be made pursuant to any judgment of any court, or otherwise, shall constitute and operate as a release of the City from any and all claims of and liability to the Contractor for anything heretofore done or furnished for the Contractor relating to or arising out of this Contract and the Work done hereunder, and for any prior act, neglect or default on the part of the City or any of its officials, agents or employees, excepting only a claim against the City for the amounts deducted or retained in accordance with the terms and provisions of this Contract or by Law, and excepting any claims, not otherwise waived, or any pending dispute resolution procedures which are contained in the

verified statement filed with the Contractor's substantial and final requisitions pursuant to Articles 44 and 45.

46.2 The Contractor is warned that the execution by it of a release, in connection with the acceptance of the final payment, containing language purporting to reserve claims other than those herein specifically excepted from the operation of this Article 46, or those for amounts deducted by the Commissioner from the final requisition or from the final payment as certified by the Engineer and approved by the Commissioner, shall not be effective to reserve such claims, anything stated to the Contractor orally or in writing by any official, agent or employee of the City to the contrary notwithstanding.

46.3 Should the Contractor refuse to accept the final payment as tendered by the Comptroller, it shall constitute a waiver of any right to interest thereon.

46.4 The Contractor, however, shall not be barred by this Article 46 from commencing an action for breach of Contract to the extent permitted by Law and by the terms of the Contract for any claims that are contained in the verified statement filed with the Contractor's substantial and final requisitions pursuant to Articles 44 and 45 or that arose after submission of the final payment requisition, provided that a detailed and verified statement of claim is served upon the contracting Agency and Comptroller not later than forty (40) Days after the making of such final payment by electronic funds transfer (EFT) or the mailing of such final payment. The statement shall specify the items upon which the claim will be based and any such claim shall be limited to such items.

ARTICLE 47. APPROVAL BY PUBLIC DESIGN COMMISSION

47.1 All works of art, including paintings, mural decorations, stained glass, statues, bas-reliefs, and other sculptures, monuments, fountains, arches, and other structures of a permanent character intended for ornament or commemoration, and every design of the same to be used in the performance of this Contract, and the design of all bridges, approaches, buildings, gates, fences, lamps, or structures to be erected, pursuant to the terms of this Contract, shall be submitted to the Art Commission, d/b/a the Public Design Commission of the City of New York, and shall be approved by the Public Design Commission prior to the erection or placing in position of the same. The final payment shall not become due or payable under this Contract unless and until the Public Design Commission shall certify that the design for the Work herein contracted for has been approved by the said Public Design Commission, and that the same has been executed in substantial accordance with the design so approved, pursuant to the provisions of Chapter 37, Section 854 of the City Charter, as amended.

CHAPTER X: CONTRACTOR'S DEFAULT

ARTICLE 48. COMMISSIONER'S RIGHT TO DECLARE CONTRACTOR IN DEFAULT

48.1 In addition to those instances specifically referred to in other Articles herein, the Commissioner shall have the right to declare the Contractor in default of this Contract if:

48.1.1 The Contractor fails to commence Work when notified to do so by the Commissioner; or if

48.1.2 The Contractor shall abandon the Work; or if

48.1.3 The Contractor shall refuse to proceed with the Work when and as directed by the Commissioner; or if

48.1.4 The Contractor shall, without just cause, reduce its working force to a number which, if maintained, would be insufficient, in the opinion of the Commissioner, to complete the Work in accordance with the progress schedule; or if

48.1.5 The Contractor shall fail or refuse to increase sufficiently such working force when ordered to do so by the Commissioner; or if

48.1.6 The Contractor shall sublet, assign, transfer, convert or otherwise dispose of this Contract other than as herein specified; or sell or assign a majority interest in the Contractor; or if

48.1.7 The Contractor fails to secure and maintain all required insurance; or if

48.1.8 A receiver or receivers are appointed to take charge of the Contractor's property or affairs; or if

48.1.9 The Commissioner shall be of the opinion that the Contractor is or has been unnecessarily or unreasonably or willfully delaying the performance and completion of the Work, or the award of necessary subcontracts, or the placing of necessary material and equipment orders; or if

48.1.10 The Commissioner shall be of the opinion that the Contractor is or has been willfully or in bad faith violating any of the provisions of this Contract; or if

48.1.11 The Commissioner shall be of the opinion that the Work cannot be completed within the time herein provided therefor or within the time to which such completion may have been extended; provided, however, that the impossibility of timely completion is, in the Commissioner's opinion, attributable to conditions within the Contractor's control; or if

48.1.12 The Work is not completed within the time herein provided therefor or within the time to which the Contractor may be entitled to have such completion extended; or if

48.1.13 Any statement or representation of the Contractor in the Contract or in any document submitted by the Contractor with respect to the Work, the Project, or the Contract (or for purposes of securing the Contract) was untrue or incorrect when made; or if

48.1.14 The Contractor or any of its officers, directors, partners, five (5%) percent shareholders, principals, or other persons substantially involved in its activities, commits any of the acts or omissions specified as the grounds for debarment in the PPB Rules.

48.2 Before the Commissioner shall exercise his/her right to declare the Contractor in default, the Commissioner shall give the Contractor an opportunity to be heard, upon not less than two (2) Days' notice.

ARTICLE 49. EXERCISE OF THE RIGHT TO DECLARE DEFAULT

49.1 The right to declare the Contractor in default for any of the grounds specified or referred to in Article 48 shall be exercised by sending the Contractor a notice, signed by the Commissioner, setting forth the ground or grounds upon which such default is declared (hereinafter referred to as a "Notice of Default").

49.2 The Commissioner's determination that the Contractor is in default shall be conclusive, final, and binding on the parties and such a finding shall preclude the Contractor from commencing a plenary action for any damages relating to the Contract. If the Contractor protests the determination of the Commissioner, the Contractor may commence an action in a court of competent jurisdiction of the State of New York under Article 78 of the New York Civil Practice Law and Rules.

ARTICLE 50. QUITTING THE SITE

50.1 Upon receipt of such notice the Contractor shall immediately discontinue all further operations under this Contract and shall immediately quit the Site, leaving untouched all plant, materials, equipment, tools, and supplies then on the Site.

ARTICLE 51. COMPLETION OF THE WORK

51.1 The Commissioner, after declaring the Contractor in default, may then have the Work completed by such means and in such manner, by contract with or without public letting, or otherwise, as he/she may deem advisable, utilizing for such purpose such of the Contractor's plant, materials, equipment, tools, and supplies remaining on the Site, and also such Subcontractors, as he/she may deem advisable.

51.2 After such completion, the Commissioner shall make a certificate stating the expense incurred in such completion, which shall include the cost of re-letting and also the total amount of liquidated damages (at the rate provided for in the Contract) from the date when the Work should have been completed by the Contractor in accordance with the terms hereof to the date of actual completion of the Work. Such certificate shall be binding and conclusive upon the Contractor, its sureties, and any person claiming under the Contractor, as to the amount thereof.

51.3 The expense of such completion, including any and all related and incidental costs, as so certified by the Commissioner, and any liquidated damages assessed against the Contractor, shall be charged against and deducted out of monies which are earned by the Contractor prior to the date of default. Should the expense of such completion, as certified by the Commissioner, exceed the total sum which would have been payable under the Contract if it had been completed by the Contractor, any excess shall be paid by the Contractor.

ARTICLE 52. PARTIAL DEFAULT

52.1 In case the Commissioner shall declare the Contractor in default as to a part of the Work only, the Contractor shall discontinue such part, shall continue performing the remainder of the Work in strict conformity with the terms of this Contract, and shall in no way hinder or interfere with any Other Contractor(s) or persons whom the Commissioner may engage to complete the Work as to which the Contractor was declared in default.

52.2 The provisions of this Chapter relating to declaring the Contractor in default as to the entire Work shall be equally applicable to a declaration of partial default, except that the Commissioner shall be entitled to utilize for completion of the part of the Work as to which the Contractor was declared in default only such plant, materials, equipment, tools, and supplies as had been previously used by the Contractor on such part.

ARTICLE 53. PERFORMANCE OF UNCOMPLETED WORK

53.1 In completing the whole or any part of the Work under the provisions of this Chapter X, the Commissioner shall have the power to depart from or change or vary the terms and provisions of this Contract, provided, however, that such departure, change or variation is made for the purpose of reducing the time or expense of such completion. Such departure, change or variation, even to the extent of accepting a lesser or different performance, shall not affect the conclusiveness of the Commissioner's certificate of the cost of completion referred to in Article 51, nor shall it constitute a defense to an action to recover the amount by which such certificate exceeds the amount which would have been payable to the Contractor hereunder but for its default.

ARTICLE 54. OTHER REMEDIES

54.1 In addition to the right to declare the Contractor in default pursuant to this Chapter X, the Commissioner shall have the absolute right, in his/her sole discretion and without a hearing, to complete or cause to be completed in the same manner as described in Articles 51 and 53, any or all unsatisfactory or uncompleted punch list Work that remains after the completion date specified in the Final Approved Punch List. A written notice of the exercise of this right shall be sent to the Contractor who shall immediately quit the Site in accordance with the provisions of Article 50.

54.2 The expense of completion permitted under Article 54.1, including any and all related and incidental costs, as so certified by the Commissioner, shall be charged against and deducted out of monies which have been earned by the Contractor prior to the date of the exercise of the right set forth in Article 54.1; the balance of such monies, if any, subject to the other provisions of this Contract, to be paid to the Contractor without interest after such completion. Should the expense of such completion, as certified by the Commissioner, exceed the total sum which would have been payable under the Contract if it had been completed by the Contractor, any excess shall be paid by the Contractor.

54.3 The previous provisions of this Chapter X shall be in addition to any and all other remedies available under Law or in equity.

54.4 The exercise by the City of any remedy set forth herein shall not be deemed a waiver by the City of any other legal or equitable remedy contained in this Contract or provided under Law.

CHAPTER XI: MISCELLANEOUS PROVISIONS

ARTICLE 55. CONTRACTOR'S WARRANTIES

55.1 In consideration of, and to induce, the award of this Contract to the Contractor, the Contractor represents and warrants:

55.1.1 That it is financially solvent, sufficiently experienced and competent to perform the Work; and

55.1.2 That the facts stated in its bid and the information given by it pursuant to the Information for Bidders is true and correct in all respects; and

55.1.3 That it has read and complied with all requirements set forth in the Contract.

ARTICLE 56. CLAIMS AND ACTIONS THEREON

56.1 Any claim, that is not subject to dispute resolution under the PPB Rules or this Contract, against the City for damages for breach of Contract shall not be made or asserted in any action, unless the Contractor shall have strictly complied with all requirements relating to the giving of notice and of information with respect to such claims, as herein before provided.

56.2 Nor shall any action be instituted or maintained on any such claims unless such action is commenced within six (6) months after Substantial Completion; except that:

56.2.1 Any claims arising out of events occurring after Substantial Completion and before Final Acceptance of the Work shall be asserted within six (6) months of Final Acceptance of the Work;

56.2.2 If the Commissioner exercises his/her right to complete or cause to complete any or all unsatisfactory or uncompleted punch list Work that remains after the completion date specified in the Final Approved Punch List pursuant to Article 54, any such action shall be commenced within six (6) months from the date the Commissioner notifies the Contractor in writing that he/she has exercised such right. Any claims for monies deducted, retained or withheld under the provisions of this Contract shall be asserted within six (6) months after the date when such monies otherwise become due and payable hereunder; and

56.2.3 If the Commissioner exercises his/her right to terminate the Contract pursuant to Article 64, any such action shall be commenced within six (6) months of the date the Commissioner exercises said right.

ARTICLE 57. INFRINGEMENT

57.1 The Contractor shall be solely responsible for and shall defend, indemnify, and hold the City harmless from any and all claims (even if the allegations of the lawsuit are without merit) and judgments for damages and from costs and expenses to which the City may be subject to or which it may suffer or incur allegedly arising out of or in connection with any infringement by the Contractor of any copyright, trade secrets, trademark or patent rights or any other property or personal right of any third party by the Contractor and/or its Subcontractors in the performance or completion of the Work. Insofar as the facts or Law relating to any claim would preclude the City from being completely indemnified by the Contractor, the City shall be partially indemnified by the Contractor to the fullest extent permitted by Law.

ARTICLE 58. NO CLAIM AGAINST OFFICIALS, AGENTS OR EMPLOYEES

58.1 No claim whatsoever shall be made by the Contractor against any official, agent or employee of the City for, or on account of, anything done or omitted to be done in connection with this Contract.

ARTICLE 59. SERVICE OF NOTICES

59.1 The Contractor hereby designates the business address, fax number, and email address specified in its bid, as the place where all notices, directions or other communications to the Contractor may be delivered, or to which they may be mailed. Any notice, direction, or communication from either party to the other shall be in writing and shall be deemed to have been given when (i) delivered personally; (ii) sent by certified mail, return receipt requested; (iii) delivered by overnight or same day courier service in a properly addressed envelope with confirmation; or (iv) sent by fax or email and, unless receipt of the fax or e-mail is acknowledged by the recipient by fax or e-mail, deposited in a post office box regularly maintained by the United States Postal Service in a properly addressed, postage pre-paid envelope.

59.2 Contractor's notice address, email address, or fax number may be changed at any time by an instrument in writing, executed and acknowledged by the Contractor, and delivered to the Commissioner.

59.3 Nothing herein contained shall, however, be deemed to preclude or render inoperative the service of any notice, direction or other communication upon the Contractor personally, or, if the Contractor is a corporation, upon any officer thereof.

ARTICLE 60. UNLAWFUL PROVISIONS DEEMED STRICKEN FROM CONTRACT

60.1 If this Contract contains any unlawful provision not an essential part of the Contract and which shall not appear to have been a controlling or material inducement to the making thereof, the same shall be deemed of no effect and shall, upon notice by either party, be deemed stricken from the Contract without affecting the binding force of the remainder.

ARTICLE 61. ALL LEGAL PROVISIONS DEEMED INCLUDED

61.1 It is the intent and understanding of the parties to this Contract that each and every provision of Law required to be inserted in this Contract shall be and is inserted herein. Furthermore, it is hereby stipulated that every such provision is to be deemed to be inserted herein, and if, through mistake or otherwise, any such provision is not inserted, or is not inserted in correct form, then this Contract shall forthwith upon the application of either party be amended by such insertion so as to comply strictly with the Law and without prejudice to the rights of either party hereunder.

ARTICLE 62. TAX EXEMPTION

62.1 The City is exempt from payment of Federal, State, and local taxes, including sales and compensating use taxes of the State of New York and its cities and counties on all tangible personal property sold to the City pursuant to the provisions of this Contract. These taxes are not to be included in bids. However, this exemption does not apply to tools, machinery, equipment or other property leased by or to the Contractor, Subcontractor or Materialman or to tangible personal property which, even

though it is consumed, is not incorporated into the completed Work (consumable supplies) and tangible personal property that the Contractor is required to remove from the Site during or upon completion of the Work. The Contractor and its Subcontractors and Materialmen shall be responsible for and pay any and all applicable taxes, including sales and compensating use taxes, on such leased tools, machinery, equipment or other property and upon all such consumable supplies and tangible personal property that the Contractor is required to remove from the Site during or upon completion of the Work.

62.2 The Contractor agrees to sell and the City agrees to purchase all tangible personal property, other than consumable supplies and other tangible personal property that the Contractor is required to remove from the Site during or upon completion of the Work, that is required, necessary or proper for or incidental to the construction of the Project covered by this Contract. The sum paid under this Contract for such tangible personal property shall be in full payment and consideration for the sale of such tangible personal property.

62.2.1 The Contractor agrees to construct the Project and to perform all Work, labor and services rendered, necessary, proper or incidental thereto for the sum shown in the bid for the performance of such Work, labor, and services, and the sum so paid pursuant to this Contract for such Work, labor, and services, shall be in full consideration for the performance by the Contractor of all its duties and obligations under this Contract in connection with said Work, labor, and services.

62.3 20 NYCRR Section 541.3(d) provides that a Contractor's purchases of tangible personal property that is either incorporated into real property owned by a governmental entity or purchased for and sold to a governmental entity are exempt from sales and use tax. The City shall not pay sales tax for any such tangible personal property that it purchases from the Contractor pursuant to the Contract. With respect to such tangible personal property, the Contractor, at the request of the City, shall furnish to the City such bills of sale and other instruments as may be required by the City, properly executed, acknowledged and delivered assuring to the City title to such tangible personal property, free of liens and/or encumbrances, and the Contractor shall mark or otherwise identify all such tangible personal property as the property of the City.

62.4 Title to all tangible personal property to be sold by the Contractor to the City pursuant to the provisions of the Contract shall immediately vest in and become the sole property of the City upon delivery of such tangible personal property to the Site. Notwithstanding such transfer of title, the Contractor shall have the full and continuing responsibility to install such tangible personal property in accordance with the provisions of this Contract, protect it, maintain it in a proper condition and forthwith repair, replace and make good any damage thereto, theft or disappearance thereof, and furnish additional tangible personal property in place of any that may be lost, stolen or rendered unusable, without cost to the City, until such time as the Work covered by the Contract is fully accepted by the City. Such transfer of title shall in no way affect any of the Contractor's obligations hereunder. In the event that, after title has passed to the City, any of the tangible personal property is rejected as being defective or otherwise unsatisfactory, title to all such tangible personal property shall be deemed to have been transferred back to the Contractor.

62.5 The purchase by Subcontractors or Materialmen of tangible personal property to be sold hereunder shall be a purchase or procurement for resale to the Contractor (either directly or through other Subcontractors) and therefore not subject to the aforesaid sales and compensating use taxes, provided that the subcontracts and purchase agreements provide for the resale of such tangible personal property and that such subcontracts and purchase agreements are in a form similar to this Contract with respect to the separation of the sale of consumable supplies and tangible personal property that the

Contractor is required to remove from the Site during or upon completion of the Work from the Work and labor, services, and any other matters to be provided, and provided further that the subcontracts and purchase agreements provide separate prices for tangible personal property and all other services and matters. Such separation shall actually be followed in practice, including the separation of payments for tangible personal property from the payments for other Work and labor and other things to be provided.

62.6 The Contractor and its Subcontractors and Materialmen shall furnish a Contractor Exempt Purchase Certificate to all persons, firms or corporations from which they purchase tangible personal property for the performance of the Work covered by this Contract.

62.7 In the event any of the provisions of this Article 62 shall be deemed to be in conflict with any other provisions of this Contract or create any ambiguity, then the provisions of this Article 62 shall control.

ARTICLE 63. INVESTIGATION(S) CLAUSE

63.1 The parties to this Contract agree to cooperate fully and faithfully with any investigation, audit or inquiry conducted by a United States, a State of New York (State) or a City governmental agency or authority that is empowered directly or by designation to compel the attendance of witnesses and to examine witnesses under oath, or conducted by the Inspector General of a governmental agency that is a party in interest to the transaction, submitted bid, submitted proposal, contract, lease, permit or license that is the subject of the investigation, audit or inquiry.

63.2 If any person who has been advised that his/her statement, and any information from such statement, will not be used against him/her in any subsequent criminal proceeding refuses to testify before a grand jury or other governmental agency or authority empowered directly or by designation to compel the attendance of witnesses and to examine witnesses under oath concerning the award of or performance under any transaction, agreement, lease, permit, contract, or license entered into with the City, the State, or any political subdivision or public authority thereof, or the Port Authority of New York and New Jersey, or any local development corporation within the City, or any public benefit corporation organized under the Laws of the State of New York, or;

63.3 If any person refuses to testify for a reason other than the assertion of his/her privilege against self incrimination in an investigation, audit or inquiry conducted by a City or State governmental agency or authority empowered directly or by designation to compel the attendance of witnesses and to take testimony under oath, or by the Inspector General of the governmental agency that is a party in interest in, and is seeking testimony concerning the award of, or performance under any transaction, agreement, lease, permit, contract, or license entered into with the City, the State, or any political subdivision thereof or any local development corporation within the City, then;

63.4 The Commissioner whose Agency is a party in interest to the transaction, submitted bid, submitted proposal, contract, lease, permit, or license shall convene a hearing, upon not less than five (5) Days' written notice to the parties involved to determine if any penalties should attach for the failure of a person to testify.

63.5 If any non-governmental party to the hearing requests an adjournment, the Commissioner who convened the hearing may, upon granting the adjournment, suspend any contract, lease, permit, or license, pending the final determination pursuant to Article 63.7 without the City incurring any penalty or damages for delay or otherwise.

63.6 The penalties which may attach after a final determination by the Commissioner may include but shall not exceed:

63.6.1 The disqualification for a period not to exceed five (5) years from the date of an adverse determination for any person, or any entity of which such person was a member at the time the testimony was sought, from submitting bids for, or transacting business with, or entering into or obtaining any contract, lease, permit or license with or from the City; and/or

63.6.2 The cancellation or termination of any and all such existing City contracts, leases, permits or licenses that the refusal to testify concerns and that have not been assigned as permitted under this Contract, nor the proceeds of which pledged, to an unaffiliated and unrelated institutional lender for fair value prior to the issuance of the notice scheduling the hearing, without the City incurring any penalty or damages on account of such cancellation or termination; monies lawfully due for goods delivered, work done, rentals, or fees accrued prior to the cancellation or termination shall be paid by the City.

63.7 The Commissioner shall consider and address in reaching his/her determination and in assessing an appropriate penalty the factors in Articles 63.7.1 and 63.7.2. The Commissioner may also consider, if relevant and appropriate, the criteria established in Articles 63.7.3 and 63.7.4, in addition to any other information which may be relevant and appropriate:

63.7.1 The party's good faith endeavors or lack thereof to cooperate fully and faithfully with any governmental investigation or audit, including but not limited to the discipline, discharge, or disassociation of any person failing to testify, the production of accurate and complete books and records, and the forthcoming testimony of all other members, agents, assignees or fiduciaries whose testimony is sought.

63.7.2 The relationship of the person who refused to testify to any entity that is a party to the hearing, including but not limited to, whether the person whose testimony is sought has an ownership interest in the entity and/or the degree of authority and responsibility the person has within the entity.

63.7.3 The nexus of the testimony sought to the subject entity and its contracts, leases, permits or licenses with the City.

63.7.4 The effect a penalty may have on an unaffiliated and unrelated party or entity that has a significant interest in an entity subject to penalties under Article 63.6, provided that the party or entity has given actual notice to the Commissioner upon the acquisition of the interest, or at the hearing called for in Article 63.4, gives notice and proves that such interest was previously acquired. Under either circumstance the party or entity shall present evidence at the hearing demonstrating the potential adverse impact a penalty will have on such person or entity.

63.8 Definitions:

63.8.1 The term "license" or "permit" as used in this Article 63 shall be defined as a license, permit, franchise or concession not granted as a matter of right.

63.8.2 The term "person" as used in this Article 63 shall be defined as any natural person doing business alone or associated with another person or entity as a partner, director, officer, principal or employee.

63.8.3 The term "entity" as used in this Article 63 shall be defined as any firm, partnership, corporation, association, joint venture, or person that receives monies, benefits, licenses, leases, or permits from or through the City or otherwise transacts business with the City.

63.8.4 The term "member" as used in this Article 63 shall be defined as any person associated with another person or entity as a partner, director, officer, principal or employee.

63.9 In addition to and notwithstanding any other provision of this Contract, the Commissioner may in his/her sole discretion terminate this Contract upon not less than three (3) Days' written notice in the event the Contractor fails to promptly report in writing to the Commissioner of the Department of Investigations ("DOP") of the City any solicitation of money, goods, requests for future employment or other benefit or thing of value, by or on behalf of any employee of the City or other person, firm, corporation or entity for any purpose which may be related to the procurement or obtaining of this Contract by the Contractor, or affecting the performance of this Contract.

ARTICLE 64: TERMINATION BY THE CITY

64.1 In addition to termination pursuant to any other article of this Contract, the Commissioner may, at any time, terminate this Contract by written notice to the Contractor. In the event of termination, the Contractor shall, upon receipt of such notice, unless otherwise directed by the Commissioner:

64.1.1 Stop Work on the date specified in the notice;

64.1.2 Take such action as may be necessary for the protection and preservation of the City's materials and property;

64.1.3 Cancel all cancelable orders for material and equipment;

64.1.4 Assign to the City and deliver to the Site or another location designated by the Commissioner, any non-cancelable orders for material and equipment that is not capable of use except in the performance of this Contract and has been specifically fabricated for the sole purpose of this Contract and not incorporated in the Work;

64.1.5 Take no action which will increase the amounts payable by the City under this Contract.

64.2 In the event of termination by the City pursuant to this Article 64, payment to the Contractor shall be in accordance with Articles 64.2.1, 64.2.2 or 64.2.3, to the extent that each respective article applies.

64.2.1 Lump Sum Contracts or Items: On all lump sum Contracts, or on lump sum items in a Contract, the City will pay the Contractor the sum of the amounts described in Articles 64.2.1(a) and 64.2.1(b), less all payments previously made pursuant to this Contract. On lump sum Contracts only, the City will also pay the Contractor an additional sum as provided in Article 64.2.1(c).

64.2.1(a) For Work completed prior to the notice of termination, the Contractor shall be paid a pro rata portion of the lump sum bid amount, plus approved change orders, based upon the percent completion of the Work, as determined by the

Commissioner. For the purpose of determining the pro rata portion of the lump sum bid amount to which the Contractor is entitled, the bid breakdown submitted in accordance with Article 41 shall be considered, but shall not be dispositive. The Commissioner's determination hereunder shall be final, binding, and conclusive.

64.2.1(b) For non-cancelable material and equipment that is not capable of use except in the performance of this Contract and has been specifically fabricated for the sole purpose of this Contract, but not yet incorporated in the Work, the Contractor shall be paid the lesser of the following, less salvage value:

64.2.1(b)(i) The Direct Cost, as defined in Article 64.2.4; or

64.2.1(b)(ii) The fair and reasonable value, if less than Direct Cost, of such material and equipment, plus necessary and reasonable delivery costs.

64.2.1(b)(iii) In addition, the Contractor shall be paid five (5%) percent of the amount described in Article 64.2.1(b)(i) or Article 64.2.1(b)(ii), whichever applies.

64.2.1(c) Except as otherwise provided in Article 64.2.1(d), on all lump sum Contracts, the Contractor shall be paid the percentage indicated below applied to the difference between the total lump sum bid amount and the total of all payments made prior to the notice of termination plus all payments allowed pursuant to Articles 64.2.1(a) and 64.2.1(b):

64.2.1(c)(i) Five (5%) percent of the first five million (\$5,000,000) dollars; and

64.2.1(c)(ii) Three (3%) percent of any amount between five million (\$5,000,000) dollars and fifteen million (\$15,000,000) dollars; plus

64.2.1(c)(iii) One (1%) percent of any amount over fifteen million (\$15,000,000) dollars.

64.2.1(d) In the event the City terminates a lump sum Contract pursuant to this Article 64 within ninety (90) Days after registration of the Contract with the Comptroller, the Contractor shall be paid one (1%) percent of the difference between the lump sum bid amount and the total of all payments made pursuant to this Article 64.2.

64.2.2 Unit Price Contracts or Items: On all unit price Contracts, or on unit price items in a Contract, the City will pay the Contractor the sum of the amounts described in Articles 64.2.2(a) and 64.2.2(b), less all payments previously made pursuant to this Contract:

64.2.2(a) For all completed units, the unit price stated in the Contract, and

64.2.2(b) For units that have been ordered but are only partially completed, the Contractor will be paid:

64.2.2(b)(i) A pro rata portion of the unit price stated in the Contract based upon the percent completion of the unit and

64.2.2(b)(ii) For non-cancelable material and equipment, payment will be made pursuant to Article 64.2.1(b).

64.2.3 Time and Materials Contracts or Items Based on Time and Material Records: On all Contracts or items in a Contract where payment for the Work is based on time and material records, the Contractor shall be paid in accordance with Article 26, less all payments previously made pursuant to this Contract.

64.2.4 Direct Costs: Direct Costs as used in this Article 64.2 shall mean:

64.2.4(a) The actual purchase price of material and equipment, plus necessary and reasonable delivery costs,

64.2.4(b) The actual cost of labor involved in construction and installation at the Site, and

64.2.4(c) The actual cost of necessary bonds and insurance purchased pursuant to requirements of this Contract less any amounts that have been or should be refunded by the Contractor's sureties or insurance carriers.

64.2.4(d) Direct Costs shall not include overhead.

64.3 In no event shall any payments under this Article 64 exceed the Contract price for such items.

64.4 All payments pursuant to Article 64 shall be in the nature of liquidated damages and shall be accepted by the Contractor in full satisfaction of all claims against the City.

64.5 The City may deduct or set off against any sums due and payable pursuant to this Article 64, any deductions authorized by this Contract or by Law (including but not limited to liquidated damages) and any claims it may have against the Contractor. The City's exercise of the right to terminate the Contract pursuant to this Article 64 shall not impair or otherwise effect the City's right to assert any claims it may have against the Contractor in a plenary action.

64.6 Where the Work covered by the Contract has been substantially completed, as determined in writing by the Commissioner, termination of the Work shall be handled as an omission of Work pursuant to Articles 29 and 33, in which case a change order will be issued to reflect an appropriate reduction in the Contract sum, or if the amount is determined after final payment, such amount shall be paid by the Contractor.

ARTICLE 65. CHOICE OF LAW, CONSENT TO JURISDICTION AND VENUE

65.1 This Contract shall be deemed to be executed in the City regardless of the domicile of the Contractor, and shall be governed by and construed in accordance with the Laws of the State of New York and the Laws of the United States, where applicable.

65.2 The parties agree that any and all claims asserted against the City arising under this Contract or related thereto shall be heard and determined in the courts of the State of New York ("New York State Courts") located in the City and County of New York. To effect this Contract and intent, the Contractor agrees:

65.2.1 If the City initiates any action against the Contractor in Federal court or in a New York State Court, service of process may be made on the Contractor either in person, wherever such Contractor may be found, or by registered mail addressed to the Contractor at its address as set forth in this Contract, or to such other address as the Contractor may provide to the City in writing; and

65.2.2 With respect to any action between the City and the Contractor in a New York State Court, the Contractor hereby expressly waives and relinquishes any rights it might otherwise have:

65.2.2(a) To move to dismiss on grounds of forum non conveniens;

65.2.2(b) To remove to Federal Court; and

65.2.2(c) To move for a change of venue to a New York State Court outside New York County.

65.2.3 With respect to any action brought by the City against the Contractor in a Federal Court located in the City, the Contractor expressly waives and relinquishes any right it might otherwise have to move to transfer the action to a Federal Court outside the City.

65.2.4 If the Contractor commences any action against the City in a court located other than in the City and County of New York, upon request of the City, the Contractor shall either consent to a transfer of the action to a New York State Court of competent jurisdiction located in the City and County of New York or, if the Court where the action is initially brought will not or cannot transfer the action, the Contractor shall consent to dismiss such action without prejudice and may thereafter reinstate the action in a New York State Court of competent jurisdiction in New York County.

65.3 If any provision(s) of this Article 65 is held unenforceable for any reason, each and all other provision(s) shall nevertheless remain in full force and effect.

ARTICLE 66. PARTICIPATION IN AN INTERNATIONAL BOYCOTT

66.1 The Contractor agrees that neither the Contractor nor any substantially owned affiliated company is participating or shall participate in an international boycott in violation of the provisions of the Federal Export Administration Act of 1979, as amended, or the regulations of the United States Department of Commerce (Commerce Department) promulgated thereunder.

66.2 Upon the final determination by the Commerce Department or any other agency of the United States as to, or conviction of the Contractor or a substantially-owned affiliated company thereof for participation in an international boycott in violation of the provisions of the Export Administration Act of 1979, as amended, or the regulations promulgated thereunder, the Comptroller may, at his/her option, render forfeit and void this Contract.

66.3 The Contractor shall comply in all respects, with the provisions of Section 6-114 of the Administrative Code and the rules and regulations issued by the Comptroller thereunder.

ARTICLE 67. LOCALLY BASED ENTERPRISE PROGRAM

67.1 This Contract is subject to the requirements of Section 6-108.1 of the Administrative Code and regulations promulgated thereunder. No construction contract shall be awarded unless and until these requirements have been complied with in their entirety; however, compliance with this Article 67 is not required if the Agency sets Subcontractor Participation Goals for Minority- and Women-Owned Business Enterprises (M/WBEs).

67.2 Unless specifically waived by the Commissioner with the approval of the Division of Economic and Financial Opportunity of the City Department of Business Services, if any portion of the Contract is subcontracted, not less than ten (10%) percent of the total dollar amount of the Contract shall be awarded to locally based enterprises (LBEs); except that where less than ten (10%) percent of the total dollar amount of the Contract is subcontracted, such lesser percentage shall be so awarded.

67.3 The Contractor shall not require performance and payment bonds from LBE Subcontractors.

67.4 If the Contractor has indicated prior to award that no Work will be subcontracted, no Work shall be subcontracted without the prior approval of the Commissioner, which shall be granted only if the Contractor makes a good faith effort beginning at least six (6) weeks before the Work is to be performed to obtain LBE Subcontractors to perform the Work.

67.5 If the Contractor has not identified sufficient LBE Subcontractors prior to award, it shall sign a letter of compliance stating that it complies with Section 6-108.1 of the Administrative Code, recognizes that achieving the LBE requirement is a condition of its Contract, and shall submit documentation demonstrating its good faith efforts to obtain LBEs. After award, the Contractor shall begin to solicit LBE's to perform subcontracted Work at least six (6) weeks before the date such Work is to be performed and shall demonstrate that a good faith effort has been made to obtain LBEs on each subcontract until it meets the required percentage.

67.6 Failure of the Contractor to comply with the requirements of Section 6-108.1 of the Administrative Code and the regulations promulgated thereunder shall constitute a material breach of this Contract. Remedy for such breach may include the imposition of any or all of the following sanctions:

67.6.1 Reducing the Contractor's compensation by an amount equal to the dollar value of the percentage of the LBE subcontracting requirement not complied with;

67.6.2 Declaring the Contractor in default;

67.6.3 If the Contractor is an LBE, de-certifying and declaring the Contractor ineligible to participate in the LBE program for a period of up to three (3) years.

ARTICLE 68. ANTITRUST

68.1 The Contractor hereby assigns, sells, and transfers to the City all right, title, and interest in and to any claims and causes of action arising under the antitrust Laws of New York State or of the United States relating to the particular goods or services purchased or procured by the City under this Contract.

ARTICLE 69. MacBRIDE PRINCIPLES PROVISIONS

69.1 Notice To All Prospective Contractors:

69.1.1 Local Law No. 34 of 1991 became effective on September 10, 1991 and added Section 6-115.1 of the Administrative Code. The local Law provides for certain restrictions on City Contracts to express the opposition of the people of the City to employment discrimination practices in Northern Ireland to promote freedom of work-place opportunity.

69.1.2 Pursuant to Section 6-115.1, prospective Contractors for Contracts to provide goods or services involving an expenditure of an amount greater than ten thousand (\$10,000.) dollars, or for construction involving an amount greater than fifteen thousand (\$15,000.) dollars, are asked to sign a rider in which they covenant and represent, as a material condition of their Contract, that any business operations in Northern Ireland conducted by the Contractor and any individual or legal entity in which the Contractor holds a ten (10%) percent or greater ownership interest in the Contractor will be conducted in accordance with the MacBride Principles of nondiscrimination in employment.

69.1.3 Prospective Contractors are not required to agree to these conditions. However, in the case of Contracts let by competitive sealed bidding, whenever the lowest responsible bidder has not agreed to stipulate to the conditions set forth in this notice and another bidder who has agreed to stipulate to such conditions has submitted a bid within five (5%) percent of the lowest responsible bid for a Contract to supply goods, services or construction of comparable quality, the Agency shall refer such bids to the Mayor, the Speaker or other officials, as appropriate, who may determine, in accordance with applicable Law, that it is in the best interest of the City that the Contract be awarded to other than the lowest responsible pursuant to Section 313(b)(2) of the City Charter.

69.1.4 In the case of Contracts let by other than competitive sealed bidding, if a prospective Contractor does not agree to these conditions, no Agency, elected official or the City Council shall award the Contract to that bidder unless the Agency seeking to use the goods, services or construction certifies in writing that the Contract is necessary for the Agency to perform its functions and there is no other responsible Contractor who will supply goods, services or construction of comparable quality at a comparable price.

69.2 In accordance with Section 6-115.1 of the Administrative Code, the Contractor stipulates that such Contractor and any individual or legal entity in which the Contractor holds a ten (10%) percent or greater ownership interest in the Contractor either:

69.2.1 Have no business operations in Northern Ireland, or

69.2.2 Shall take lawful steps in good faith to conduct any business operations they have in Northern Ireland in accordance with the MacBride Principles, and shall permit independent monitoring of their compliance with such principles.

69.3 For purposes of this Article, the following terms shall have the following meanings:

69.3.1 "MacBride Principles" shall mean those principles relating to nondiscrimination in employment and freedom of work-place opportunity which require employers doing business in Northern Ireland to:

69.3.1(a) increase the representation of individuals from under-represented religious groups in the workforce, including managerial, supervisory, administrative, clerical and technical jobs;

69.3.1(b) take steps to promote adequate security for the protection of employees from under-represented religious groups both at the work-place and while traveling to and from Work;

69.3.1(c) ban provocative religious or political emblems from the workplace;

69.3.1(d) publicly advertise all job openings and make special recruitment efforts to attract applicants from under-represented religious groups;

69.3.1(e) establish layoff, recall, and termination procedures which do not in practice favor a particular religious group;

69.3.1(f) abolish all job reservations, apprenticeship restrictions and different employment criteria which discriminate on the basis of religion;

69.3.1(g) develop training programs that will prepare substantial numbers of current employees from under-represented religious groups for skilled jobs, including the expansion of existing programs and the creation of new programs to train, upgrade, and improve the skills of workers from under-represented religious groups;

69.3.1(h) establish procedures to assess, identify, and actively recruit employees from under-represented religious groups with potential for further advancement; and

69.3.1(i) appoint a senior management staff member to oversee affirmative action efforts and develop a timetable to ensure their full implementation.

69.4 The Contractor agrees that the covenants and representations in Article 69.2 are material conditions to this Contract. In the event the Agency receives information that the Contractor who made the stipulation required by this Article 69 is in violation thereof, the Agency shall review such information and give the Contractor an opportunity to respond. If the Agency finds that a violation has occurred, the Agency shall have the right to declare the Contractor in default and/or terminate this Contract for cause and procure supplies, services or Work from another source in the manner the Agency deems proper. In the event of such termination, the Contractor shall pay to the Agency, or the Agency in its sole discretion may withhold from any amounts otherwise payable to the Contractor, the difference between the Contract price for the uncompleted portion of this Contract and the cost to the Agency of completing performance of this Contract either itself or by engaging another Contractor or Contractors. In the case of a requirement Contract, the Contractor shall be liable for such difference in price for the entire amount of supplies required by the Agency for the uncompleted term of Contractor's Contract. In the case of a construction Contract, the Agency shall also have the right to hold the Contractor in partial or total default in accordance with the default provisions of this Contract, and/or may seek debarment or suspension of the Contractor. The rights and remedies of the Agency hereunder shall be in addition to, and not in lieu of, any rights and remedies the Agency has pursuant to this Contract or by operation of Law.

ARTICLE 70. ELECTRONIC FILING/NYC DEVELOPMENT HUB

70.1 The Contractor shall electronically file all alteration type-2 and alteration type-3 applications via the New York City Development Hub Web site, except applications for the following types of minor alterations: enlargements, curb cuts, legalizations, fire alarms, builders pavement plans, and jobs filed on Landmark Preservation Commission calendared properties. All such filings must be professionally certified. Information about electronic filing via the New York City Development Hub is available on the City Department of Buildings Web site at www.nyc.gov/buildings.

ARTICLE 71. PROHIBITION OF TROPICAL HARDWOODS

71.1 Tropical hardwoods, as defined in Section 165 of the New York State Finance Law (Finance Law), shall not be utilized in the performance of this Contract except as expressly permitted by Section 165 of the Finance Law.

ARTICLE 72. CONFLICTS OF INTEREST

72.1 Section 2604 of the City Charter and other related provisions of the City Charter, the Administrative Code, and the Penal Law are applicable under the terms of this Contract in relation to conflicts of interest and shall be extended to Subcontractors authorized to perform Work, labor and services pursuant to this Contract and further, it shall be the duty and responsibility of the Contractor to so inform its respective Subcontractors. Notice is hereby given that, under certain circumstances, penalties may be invoked against the donor as well as the recipient of any form of valuable gift.

ARTICLE 73. MERGER CLAUSE

73.1 The written Contract herein, contains all the terms and conditions agreed upon by the parties hereto, and no other agreement, oral or otherwise, regarding the subject matter of this Contract shall be deemed to exist or to bind any of the parties hereto, or to vary any of the terms contained herein.

ARTICLE 74. STATEMENT OF WORK

74.1 The Contractor shall furnish all labor and materials and perform all Work in strict accordance with the Specifications and Addenda thereto, numbered as shown in Schedule A.

ARTICLE 75. COMPENSATION TO BE PAID TO CONTRACTOR

75.1 The City will pay and the Contractor will accept in full consideration for the performance of the Contract, subject to additions and deductions as provided herein, the total sum shown in Schedule A, this said sum being the amount at which the Contract was awarded to the Contractor at a public letting thereof, based upon the Contractor's bid for the Contract.

ARTICLE 76. ELECTRONIC FUNDS TRANSFER

76.1 In accordance with Section 6-107.1 of the Administrative Code, the Contractor agrees to accept payments under this Contract from the City by electronic funds transfer (EFT). An EFT is any

transfer of funds, other than a transaction originated by check, draft or similar paper instrument, which is initiated through an electronic terminal, telephonic instrument or computer or magnetic tape so as to order, instruct or authorize a financial institution to debit or credit an account. Prior to the first payment made under this Contract, the Contractor shall designate one financial institution or other authorized payment agent and shall complete the attached "EFT Vendor Payment Enrollment Form" in order to provide the Commissioner of the City Department of Finance with information necessary for the Contractor to receive electronic funds transfer payments through a designated financial institution or authorized payment agent. The crediting of the amount of a payment to the appropriate account on the books of a financial institution or other authorized payment agent designated by the Contractor shall constitute full satisfaction by the City for the amount of the payment under this Contract. The account information supplied by the Contractor to facilitate the electronic funds transfer shall remain confidential to the fullest extent provided by Law.

76.2 The Commissioner may waive the application of the requirements of this Article 76 to payments on contracts entered into pursuant to Section 315 of the City Charter. In addition, the Commissioner of the Department of Finance and the Comptroller may jointly issue standards pursuant to which the Agency may waive the requirements of this Article 76 for payments in the following circumstances: (i) for individuals or classes of individuals for whom compliance imposes a hardship; (ii) for classifications or types of checks; or (iii) in other circumstances as may be necessary in the interest of the City.

ARTICLE 77. RECORDS RETENTION

77.1 The Contractor agrees to retain all books, records, and other documents relevant to this Contract for six years after the final payment or termination of this Contract, whichever is later. City, state, and federal auditors and any other persons duly authorized by the City shall have full access to and the right to examine any such books, records, and other documents during the retention period.

ARTICLE 78. EXAMINATION AND VIEWING OF SITE, CONSIDERATION OF OTHER SOURCES OF INFORMATION AND CHANGED SITE CONDITIONS

78.1 Pre-Bidding (Investigation) Viewing of Site – Bidders must carefully view and examine the Site of the proposed Work, as well as its adjacent area, and seek other usual sources of information, for they will be conclusively presumed to have full knowledge of any and all conditions and hazards on, about or above the Site relating to or affecting in any way the performance of the Work to be done under the Contract that were or should have been known by a reasonably prudent bidder. To arrange a date for visiting the Site, bidders are to contact the Agency contact person specified in the bid documents.

78.2 Should the Contractor encounter during the progress of the Work site conditions or environmental hazards at the Site materially differing from any shown on the Contract Drawings or indicated in the Specifications or such conditions or environmental hazards as could not reasonably have been anticipated by the Contractor, which conditions or hazards will materially affect the cost of the Work to be done under the Contract, the attention of the Commissioner must be called immediately to such conditions or hazards before they are disturbed. The Commissioner shall thereupon promptly investigate the conditions or hazards. If the Commissioner finds that they do so materially differ, and that they could not have been reasonably anticipated by the Contractor, the Contract may be modified with the Commissioner's written approval.

**ARTICLE 79. PARTICIPATION BY MINORITY-OWNED AND WOMEN-OWNED
BUSINESS ENTERPRISES IN CITY PROCUREMENT**

NOTICE TO ALL PROSPECTIVE CONTRACTORS

ARTICLE I. M/WBE PROGRAM

Local Law No. 129 of 2005 added and Local Law 1 of 2013 amended Section 6-129 of the Administrative Code of the City of New York (hereinafter "Section 6-129"). Section 6-129 establishes the program for participation in City procurement ("M/WBE Program") by minority-owned business enterprises ("MBEs") and women-owned business enterprises ("WBEs"), certified in accordance with Section 1304 of the New York City Charter. As stated in Section 6-129, the intent of the program is to address the impact of discrimination on the City's procurement process, and to promote the public interest in avoiding fraud and favoritism in the procurement process, increasing competition for City business, and lowering contract costs. The contract provisions contained herein are pursuant to Section 6-129, and the rules of the Department of Small Business Services ("DSBS") promulgated thereunder.

If this Contract is subject to the M/WBE Program established by Section 6-129, the specific requirements of MBE and/or WBE participation for this Contract are set forth in Schedule B of the Contract (entitled the "M/WBE Utilization Plan"), and are detailed below. The Contractor must comply with all applicable MBE and WBE requirements for this Contract.

All provisions of Section 6-129 are hereby incorporated in the Contract by reference and all terms used herein that are not defined herein shall have the meanings given such terms in Section 6-129. Article I, Part A, below, sets forth provisions related to the participation goals for construction, standard and professional services contracts. Article I, Part B, below, sets forth miscellaneous provisions related to the M/WBE Program.

PART A

**PARTICIPATION GOALS FOR CONSTRUCTION, STANDARD
AND PROFESSIONAL SERVICES CONTRACTS OR TASK ORDERS**

1. The MBE and/or WBE Participation Goals established for this Contract or Task Orders issued pursuant to this Contract, ("Participation Goals"), as applicable, are set forth on Schedule B, Part I to this Contract (see Page 1, line 1 Total Participation Goals) or will be set forth on Schedule B, Part I to Task Orders issued pursuant to this Contract, as applicable.

The Participation Goals represent a percentage of the total dollar value of the Contract or Task Order, as applicable, that may be achieved by awarding subcontracts to firms certified with New York City Department of Small Business Services as MBEs and/or WBEs, and/or by crediting the participation of prime contractors and/or qualified joint ventures as provided in Section 3 below, unless the goals have been waived or modified by Agency in accordance with Section 6-129 and Part A, Sections 10 and 11 below, respectively.

2. If Participation Goals have been established for this Contract or Task Orders issued pursuant to this Contract, Contractor agrees or shall agree as a material term of the Contract that Contractor shall be subject to the Participation Goals, unless the goals are waived or modified by Agency in accordance with Section 6-129 and Part A, Sections 10 and 11 below, respectively.

3. If Participation Goals have been established for this Contract or Task Order issued pursuant to this Contract, a Contractor that is an MBE and/or WBE shall be permitted to count its own participation toward fulfillment of the relevant Participation Goal, provided that in accordance with Section 6-129 the value of Contractor's participation shall be determined by subtracting from the total value of the Contract or Task Order, as applicable, any amounts that the Contractor pays to direct subcontractors (as defined in Section 6-129(c)(13)), and provided further that a Contractor that is certified as both an MBE and a WBE may count its own participation either toward the goal for MBEs or the goal for WBEs, but not both.

A Contractor that is a qualified joint venture (as defined in Section 6-129(c)(30)) shall be permitted to count a percentage of its own participation toward fulfillment of the relevant Participation Goal. In accordance with Section 6-129, the value of Contractor's participation shall be determined by subtracting from the total value of the Contract or Task Order, as applicable, any amounts that Contractor pays to direct subcontractors, and then multiplying the remainder by the percentage to be applied to total profit to determine the amount to which an MBE or WBE is entitled pursuant to the joint venture agreement, provided that where a participant in a joint venture is certified as both an MBE and a WBE, such amount shall be counted either toward the goal for MBEs or the goal for WBEs, but not both.

4. A. If Participation Goals have been established for this Contract, a prospective contractor shall be required to submit with its bid or proposal, as applicable, a completed Schedule B, M/WBE Utilization Plan, Part II (see Pages 2-4) indicating: (a) whether the contractor is an MBE or WBE, or qualified joint venture; (b) the percentage of work it intends to award to direct subcontractors; and (c) in cases where the contractor intends to award direct subcontracts, a description of the type and dollar value of work designated for participation by MBEs and/or WBEs, and the time frames in which such work is scheduled to begin and end. In the event that this M/WBE Utilization Plan indicates that the bidder or proposer, as applicable, does not intend to meet the Participation Goals, the bid or proposal, as applicable, shall be deemed non-responsive, unless Agency has granted the bidder or proposer, as applicable, a pre-award waiver of the Participation Goals in accordance with Section 6-129 and Part A, Section 10 below.

B. (i) If this Contract is for a master services agreement or other requirements type contract that will result in the issuance of Task Orders that will be individually registered ("Master Services Agreement") and is subject to M/WBE Participation Goals, a prospective contractor shall be required to submit with its bid or proposal, as applicable, a completed Schedule B, M/WBE Participation Requirements for Master Services Agreements That Will Require Individually Registered Task Orders, Part II (page 2) indicating the prospective contractor's certification and required affirmations to make all reasonable good faith efforts to meet participation goals established on each individual Task Order issued pursuant to this Contract, or if a partial waiver is obtained or such goals are modified by the Agency, to meet the modified Participation Goals by soliciting and obtaining the participation of certified MBE and/or WBE firms. In the event that the Schedule B indicates that the bidder or proposer, as applicable, does not intend to meet the Participation Goals that may be established on Task Orders issued pursuant to this Contract, the bid or proposal, as applicable, shall be deemed nonresponsive.

(ii) Participation Goals on a Master Services Agreement will be established for individual Task Orders issued after the Master Services Agreement is awarded. If Participation Goals have been established on a Task Order, a contractor shall be required to submit a Schedule B - M/WBE Utilization Plan For Independently Registered Task Orders That Are Issued Pursuant to Master Services Agreements, Part II (see Pages 2-4) indicating: (a) whether the contractor is an MBE or WBE, or qualified joint venture; (b) the percentage of work it intends to award to direct subcontractors; and (c) in cases where the contractor intends to award direct subcontracts, a description of the type and dollar value of work designated for participation by MBEs and/or WBEs, and the time frames in which such work is scheduled to begin and end. The contractor must engage in good faith efforts to meet the Participation Goals as established for the Task Order unless Agency has granted the contractor a pre-award waiver of the Participation Goals in accordance with Section 6-129 and Part A, Section 10 below.

C. THE BIDDER/PROPOSER MUST COMPLETE THE SCHEDULE B INCLUDED HEREIN (SCHEDULE B, PART II). A SCHEDULE B SUBMITTED BY THE BIDDER/PROPOSER WHICH DOES NOT INCLUDE THE VENDOR CERTIFICATION AND REQUIRED AFFIRMATIONS (SEE SECTION V OF PART II) WILL BE DEEMED TO BE NON-RESPONSIVE, UNLESS A FULL WAIVER OF THE PARTICIPATION GOALS IS GRANTED (SCHEDULE B, PART III). IN THE EVENT THAT THE CITY DETERMINES THAT THE BIDDER/PROPOSER HAS SUBMITTED A SCHEDULE B WHERE THE VENDOR CERTIFICATION AND REQUIRED AFFIRMATIONS ARE COMPLETED BUT OTHER ASPECTS OF THE SCHEDULE B ARE NOT COMPLETE, OR CONTAIN A COPY OR COMPUTATION ERROR THAT IS AT ODDS WITH THE VENDOR CERTIFICATION AND AFFIRMATIONS, THE BIDDER/PROPOSER WILL BE NOTIFIED BY THE AGENCY AND WILL BE GIVEN FOUR (4) CALENDAR DAYS FROM RECEIPT OF NOTIFICATION TO CURE THE SPECIFIED DEFICIENCIES AND RETURN A COMPLETED SCHEDULE B TO THE AGENCY. FAILURE TO DO SO WILL RESULT IN A DETERMINATION THAT THE BID/PROPOSAL IS NON-RESPONSIVE. RECEIPT OF NOTIFICATION IS DEFINED AS THE DATE NOTICE IS E-MAILED OR FAXED (IF THE BIDDER/PROPOSER HAS PROVIDED AN E-MAIL ADDRESS OR FAX NUMBER), OR NO LATER THAN FIVE (5) CALENDAR DAYS FROM THE DATE OF MAILING OR UPON DELIVERY, IF DELIVERED.

5. Where an M/WBE Utilization Plan has been submitted, the Contractor shall, within 30 days of issuance by Agency of a notice to proceed, submit a list of proposed persons or entities to which it intends to award subcontracts within the subsequent 12 months. In the case of multiyear contracts, such list shall also be submitted every year thereafter. The Agency may also require the Contractor to report periodically about the contracts awarded by its direct subcontractors to indirect subcontractors (as defined in Section 6-129(c)(22)). **PLEASE NOTE: If this Contract is a public works project subject to GML §101(5) (i.e., a contract valued at or below \$3M for projects in New York City) or if the Contract is subject to a project labor agreement in accordance with Labor Law §222, and the bidder is required to identify at the time of bid submission its intended subcontractors for the Wicks trades (plumbing and gas fitting, steam heating, hot water heating, ventilating and air conditioning (HVAC), and electric wiring), the Contractor must identify all those to which it intends to award construction subcontracts for any portion of the Wicks trade work at the time of bid submission, regardless of what point in the life of the contract such subcontracts will occur. In identifying intended subcontractors in the bid submission, bidders may satisfy any Participation Goals established for this Contract by proposing one or more subcontractors that are MBEs and/or WBEs for any portion of the Wicks trade work. In the event that the Contractor's selection of a subcontractor is disapproved, the Contractor shall have a reasonable time to propose alternate subcontractors.**

6. MBE and WBE firms must be certified by DSBS in order for the Contractor to credit such firms' participation toward the attainment of the Participation Goals. Such certification must occur prior to the

firms' commencement of work. A list of MBE and WBE firms may be obtained from the DSBS website at www.nyc.gov/buycertified, by emailing DSBS at buyer@sbs.nyc.gov, by calling (212) 513-6356, or by visiting or writing DSBS at 110 William St., New York, New York, 10038, 7th floor. Eligible firms that have not yet been certified may contact DSBS in order to seek certification by visiting www.nyc.gov/getcertified, emailing MWBE@sbs.nyc.gov, or calling the DSBS certification helpline at (212) 513-6311. A firm that is certified as both an MBE and a WBE may be counted either toward the goal for MBEs or the goal for WBEs, but not both. No credit shall be given for participation by a graduate MBE or graduate WBE, as defined in Section 6-129(c)(20).

7. Where an M/WBE Utilization Plan has been submitted, the Contractor shall, with each voucher for payment, and/or periodically as Agency may require, submit statements, certified under penalty of perjury, which shall include, but not be limited to, the total amount the Contractor paid to its direct subcontractors, and, where applicable pursuant to Section 6-129(j), the total amount direct subcontractors paid to indirect subcontractors; the names, addresses and contact numbers of each MBE or WBE hired as a subcontractor by the Contractor, and, where applicable, hired by any of the Contractor's direct subcontractors; and the dates and amounts paid to each MBE or WBE. The Contractor shall also submit, along with its voucher for final payment: the total amount it paid to subcontractors, and, where applicable pursuant to Section 6-129(j), the total amount its direct subcontractors paid directly to their indirect subcontractors; and a final list, certified under penalty of perjury, which shall include the name, address and contact information of each subcontractor that is an MBE or WBE, the work performed by, and the dates and amounts paid to each.

8. If payments made to, or work performed by, MBEs or WBEs are less than the amount specified in the Contractor's M/WBE Utilization Plan, Agency shall take appropriate action, in accordance with Section 6-129 and Article II below, unless the Contractor has obtained a modification of its M/WBE Utilization Plan in accordance with Section 6-129 and Part A, Section 11 below.

9. Where an M/WBE Utilization Plan has been submitted, and the Contractor requests a change order the value of which exceeds the greater of 10 percent of the Contract or Task Order, as applicable, or \$500,000, Agency shall review the scope of work for the Contract or Task Order, as applicable, and the scale and types of work involved in the change order, and determine whether the Participation Goals should be modified.

10. Pre-award waiver of the Participation Goals. (a) A bidder or proposer, or contractor with respect to a Task Order, may seek a pre-award full or partial waiver of the Participation Goals in accordance with Section 6-129, which requests that Agency change one or more Participation Goals on the grounds that the Participation Goals are unreasonable in light of the availability of certified firms to perform the services required, or by demonstrating that it has legitimate business reasons for proposing a lower level of subcontracting in its M/WBE Utilization Plan.

(b) To apply for a full or partial waiver of the Participation Goals, a bidder, proposer, or contractor, as applicable, must complete Part III (Page 5) of Schedule B and submit such request no later than seven (7) calendar days prior to the date and time the bids, proposals, or Task Orders are due, in writing to the Agency by email at poped@ddc.nyc.gov or via facsimile at (718) 391-1886. Bidders, proposers, or contractors, as applicable, who have submitted requests will receive an Agency response by no later than two (2) calendar days prior to the due date for bids, proposals, or Task Orders; provided, however, that if that date would fall on a weekend or holiday, an Agency response will be provided by close-of-business on the business day before such weekend or holiday date.

(c) If the Agency determines that the Participation Goals are unreasonable in light of the availability of certified firms to perform the services required, it shall revise the solicitation and extend the deadline for bids and proposals, or revise the Task Order, as applicable.

(d) Agency may grant a full or partial waiver of the Participation Goals to a bidder, proposer or contractor, as applicable, who demonstrates—before submission of the bid, proposal or Task Order, as applicable—that it has legitimate business reasons for proposing the level of subcontracting in its M/WBE Utilization Plan. In making its determination, Agency shall consider factors that shall include, but not be limited to, whether the bidder, proposer or contractor, as applicable, has the capacity and the bona fide intention to perform the Contract without any subcontracting, or to perform the Contract without awarding the amount of subcontracts represented by the Participation Goals. In making such determination, Agency may consider whether the M/WBE Utilization Plan is consistent with past subcontracting practices of the bidder, proposer or contractor, as applicable, whether the bidder, proposer or contractor, as applicable, has made efforts to form a joint venture with a certified firm, and whether the bidder, proposer, or contractor, as applicable, has made good faith efforts to identify other portions of the Contract that it intends to subcontract.

11. Modification of M/WBE Utilization Plan. (a) A Contractor may request a modification of its M/WBE Utilization Plan after award of this Contract. PLEASE NOTE: If this Contract is a public works project subject to GML §101(5) (i.e., a contract valued at or below \$3M for projects in New York City) or if the Contract is subject to a project labor agreement in accordance with Labor Law §222, and the bidder is required to identify at the time of bid submission its intended subcontractors for the Wicks trades (plumbing and gas fitting; steam heating, hot water heating, ventilating and air conditioning (HVAC); and electric wiring), the Contractor may request a Modification of its M/WBE Utilization Plan as part of its bid submission. The Agency may grant a request for Modification of a Contractor's M/WBE Utilization Plan if it determines that the Contractor has established, with appropriate documentary and other evidence, that it made reasonable, good faith efforts to meet the Participation Goals. In making such determination, Agency shall consider evidence of the following efforts, as applicable, along with any other relevant factors:

- (i) The Contractor advertised opportunities to participate in the Contract, where appropriate, in general circulation media, trade and professional association publications and small business media, and publications of minority and women's business organizations;
- (ii) The Contractor provided notice of specific opportunities to participate in the Contract, in a timely manner, to minority and women's business organizations;
- (iii) The Contractor sent written notices, by certified mail or facsimile, in a timely manner, to advise MBEs or WBEs that their interest in the Contract was solicited;
- (iv) The Contractor made efforts to identify portions of the work that could be substituted for portions originally designated for participation by MBEs and/or WBEs in the M/WBE Utilization Plan, and for which the Contractor claims an inability to retain MBEs or WBEs;
- (v) The Contractor held meetings with MBEs and/or WBEs prior to the date their bids or proposals were due, for the purpose of explaining in detail the scope and requirements of the work for which their bids or proposals were solicited;
- (vi) The Contractor made efforts to negotiate with MBEs and/or WBEs as relevant to perform specific subcontracts, or act as suppliers or service providers;
- (vii) Timely written requests for assistance made by the Contractor to Agency's M/WBE liaison officer and to DSBS;
- (viii) Description of how recommendations made by DSBS and Agency were acted upon and an explanation of why action upon such recommendations did not lead to the desired level of participation of MBEs and/or WBEs.

Agency's M/WBE officer shall provide written notice to the Contractor of the determination.

(b) The Agency may modify the Participation Goals when the scope of the work has been changed by the Agency in a manner that affects the scale and types of work that the Contractor indicated in its M/WBE Utilization Plan would be awarded to subcontractors.

12. If this Contract is for an indefinite quantity of construction, standard or professional services or is a requirements type contract and the Contractor has submitted an M/WBE Utilization Plan and has committed to subcontract work to MBEs and/or WBEs in order to meet the **Participation Goals**, the Contractor will not be deemed in violation of the M/WBE Program requirements for this Contract with regard to any work which was intended to be subcontracted to an MBE and/or WBE to the extent that the Agency has determined that such work is not needed.

13. If **Participation Goals** have been established for this Contract or a Task Order issued pursuant to this Contract, at least once annually during the term of the Contract or Task Order, as applicable, Agency shall review the Contractor's progress toward attainment of its M/WBE Utilization Plan, including but not limited to, by reviewing the percentage of work the Contractor has actually awarded to MBE and/or WBE subcontractors and the payments the Contractor made to such subcontractors.

14. If **Participation Goals** have been established for this Contract or a Task Order issued pursuant to this Contract, Agency shall evaluate and assess the Contractor's performance in meeting those goals, and such evaluation and assessment shall become part of the Contractor's overall contract performance evaluation.

PART B: MISCELLANEOUS

1. The Contractor shall take notice that, if this solicitation requires the establishment of an M/WBE Utilization Plan, the resulting contract may be audited by DSBS to determine compliance with Section 6-129. See §6-129(e)(10). Furthermore, such resulting contract may also be examined by the City's Comptroller to assess compliance with the M/WBE Utilization Plan.

2. Pursuant to DSBS rules, construction contracts that include a requirement for an M/WBE Utilization Plan shall not be subject to the law governing Locally Based Enterprises set forth in Section 6-108.1 of the Administrative Code of the City of New York.

3. DSBS is available to assist contractors and potential contractors in determining the availability of MBEs and/or WBEs to participate as subcontractors, and in identifying opportunities that are appropriate for participation by MBEs and/or WBEs in contracts.

4. Prospective contractors are encouraged to enter into qualified joint venture agreements with MBEs and/or WBEs as defined by Section 6-129(c)(30).

5. By submitting a bid or proposal the Contractor hereby acknowledges its understanding of the M/WBE Program requirements set forth herein and the pertinent provisions of Section 6-129, and any rules promulgated thereunder, and if awarded this Contract, the Contractor hereby agrees to comply with the M/WBE Program requirements of this Contract and pertinent provisions of Section 6-129, and any rules promulgated thereunder, all of which shall be deemed to be material terms of this Contract. The Contractor hereby agrees to make all reasonable, good faith efforts to solicit and obtain the participation of MBEs and/or WBEs to meet the required **Participation Goals**.

ARTICLE II. ENFORCEMENT

1. If Agency determines that a bidder or proposer, as applicable, has, in relation to this procurement, violated Section 6-129 or the DSBS rules promulgated pursuant to Section 6-129, Agency may disqualify such bidder or proposer, as applicable, from competing for this Contract and the Agency may revoke such bidder's or proposer's prequalification status, if applicable.

2. Whenever Agency believes that the Contractor or a subcontractor is not in compliance with Section 6-129 or the DSBS rules promulgated pursuant to Section 6-129, or any provision of this Contract that implements Section 6-129, including, but not limited to any M/WBE Utilization Plan, Agency shall send a written notice to the Contractor describing the alleged noncompliance and offering the Contractor an opportunity to be heard. Agency shall then conduct an investigation to determine whether such Contractor or subcontractor is in compliance.

3. In the event that the Contractor has been found to have violated Section 6-129, the DSBS rules promulgated pursuant to Section 6-129, or any provision of this Contract that implements Section 6-129, including, but not limited to, any M/WBE Utilization Plan, Agency may determine that one of the following actions should be taken:

- (a) entering into an agreement with the Contractor allowing the Contractor to cure the violation;
- (b) revoking the Contractor's pre-qualification to bid or make proposals for future contracts;
- (c) making a finding that the Contractor is in default of the Contract;
- (d) terminating the Contract;
- (e) declaring the Contractor to be in breach of Contract;
- (f) withholding payment or reimbursement;
- (g) determining not to renew the Contract;
- (h) assessing actual and consequential damages;
- (i) assessing liquidated damages or reducing fees, provided that liquidated damages may be based on amounts representing costs of delays in carrying out the purposes of the M/WBE Program, or in meeting the purposes of the Contract, the costs of meeting utilization goals through additional procurements, the administrative costs of investigation and enforcement, or other factors set forth in the Contract;
- (j) exercising rights under the Contract to procure goods, services or construction from another contractor and charge the cost of such contract to the Contractor that has been found to be in noncompliance; or
- (k) taking any other appropriate remedy.

4. If an M/WBE Utilization Plan has been submitted, and pursuant to this Article II, Section 3, the Contractor has been found to have failed to fulfill its Participation Goals contained in its M/WBE Utilization Plan or the Participation Goals as modified by Agency pursuant to Article I, Part A, Section 11, Agency may assess liquidated damages in the amount of ten percent (10%) of the difference between the dollar amount of work required to be awarded to MBE and/or WBE firms to meet the Participation Goals and the dollar amount the Contractor actually awarded and paid, and/or credited, to MBE and/or WBE firms. In view of the difficulty of accurately ascertaining the loss which the City will suffer by reason of Contractor's failure to meet the Participation Goals, the foregoing amount is hereby fixed and agreed as the liquidated damages that the City will suffer by reason of such failure, and not as a penalty. Agency may deduct and retain out of any monies which may become due under this Contract the amount of any such liquidated damages; and in case the amount which may become due under this Contract shall be less than the amount of liquidated damages suffered by the City, the Contractor shall be liable to pay the difference.

5. Whenever Agency has reason to believe that an MBE and/or WBE is not qualified for certification, or is participating in a contract in a manner that does not serve a commercially useful function (as defined in Section 6-129(c)(8)), or has violated any provision of Section 6-129, Agency shall notify the Commissioner of DSBS who shall determine whether the certification of such business enterprise should be revoked.

6. Statements made in any instrument submitted to Agency pursuant to Section 6-129 shall be submitted under penalty of perjury and any false or misleading statement or omission shall be grounds for the application of any applicable criminal and/or civil penalties for perjury. The making of a false or fraudulent statement by an MBE and/or WBE in any instrument submitted pursuant to Section 6-129 shall, in addition, be grounds for revocation of its certification.

7. The Contractor's record in implementing its M/WBE Utilization Plan shall be a factor in the evaluation of its performance. Whenever Agency determines that a Contractor's compliance with an M/WBE Utilization Plan has been unsatisfactory, Agency shall, after consultation with the City Chief Procurement Officer, file an advice of caution form for inclusion in VENDEX as caution data.

IN WITNESS WHEREOF, the Commissioner, on behalf of the City of New York, and the Contractor, have executed this agreement in quadruplicate, two parts of which are to remain with the Commissioner, another to be filed with the Comptroller of the City, and the fourth to be delivered to the Contractor.

THE CITY OF NEW YORK

By: Lorraine Gallo
Commissioner

CONTRACTOR:

By: James Giv
(Member of Firm or Officer of Corporation)

Title: PRESIDENT

(Where Contractor is a Corporation, add):
Attest:

Secretary

(Seal)

ACKNOWLEDGEMENT OF PRINCIPAL, IF A CORPORATION

State of _____ County of _____ ss:

On this _____ day of _____, _____, before me personally came _____ to me known who, being by me duly sworn did depose and say that he resides at _____ that he is the _____ of the corporation described in and which executed the foregoing instrument; that he knows the seal of said corporation; that one of the seals affixed to said instrument is such seal; that it was so affixed by order of the directors of said corporation, and that he signed his name thereto by like order.

Notary Public or Commissioner of Deeds

LLC

ACKNOWLEDGEMENT OF PRINCIPAL, IF A PARTNERSHIP

State of NEW YORK County of QUEENS ss:

On this 3rd day of JUNE, 2020, before me personally appeared DOMENICK Cipollone to me known, and known to me to be one of the members of the firm of ADC CONSTRUCTION, LLC described in and who executed the foregoing instrument; and he acknowledged to me that he executed the same as and for the act and deed of said firm.

Melissa Gallagher
Notary Public or Commissioner of Deeds

MELISSA GALLAGHER
NOTARY PUBLIC, STATE OF NEW YORK
Registration No. 01GA6013314
Qualified in Queens County
Commission Expires 09-14-2022

ACKNOWLEDGEMENT OF PRINCIPAL, IF AN INDIVIDUAL

State of _____ County of _____ ss:

On this _____ day of _____, _____, before me personally appeared _____ to me known, and known to me to be the person described in and who executed the foregoing instrument; and acknowledged that he executed the same.

Notary Public or Commissioner of Deeds

MELISSA GALLAGHER
NOTARY PUBLIC, STATE OF NEW YORK
Registration No. 01GA6013314
Qualified in Queens County
Commission Expires 09-14-2022

ACKNOWLEDGEMENT BY COMMISSIONER

State of _____ County of _____ ss:

On this _____ day of _____, _____, before me personally came _____ to me known, and known to be the Deputy Commissioner of the Department of Design and Construction of The City of New York, the person described as such in and who as such executed the foregoing instrument and acknowledged to me that he executed the same as Deputy Commissioner for the purposes therein mentioned.

Notary Public or Commissioner of Deeds

AUTHORITY

MAYOR'S CERTIFICATE NO. CBX
BUDGET DIRECTOR'S CERTIFICATE NO.

DATED
DATED

APPROPRIATION
COMMISSIONER'S CERTIFICATE

In conformity with the provisions of Section 6-101 of the Administrative Code of the City of New York, it is hereby certified that the estimated cost of the work, materials and supplies required by the within Contract, amounting to

seven million five hundred eighty-six thousand

forty-seven and seven tenths

Dollars (\$ 7,586,047.70)

is chargeable to the fund of the Department of Design and Construction entitled Code

SEQBN11

Department of Design and Construction

I hereby certify that the specifications contained herein comply with the terms and conditions of the BUDGET.

Lorraine Gallo

Commissioner

COMPTROLLER'S CERTIFICATE

The City of New York _____

Pursuant to the provisions of Section 6-101 of the Administrative Code of the City of New York, I hereby certify that there remains unapplied and unexpended a balance of the above mentioned fund applicable to this Contract sufficient to pay the estimated expense of executing the same viz:

\$ _____

Comptroller

**MAYOR'S CERTIFICATE OR
CERTIFICATE OF THE DIRECTOR
OF THE BUDGET**

Performance Bond #1 (Pages 100 to 103): Use if the total contract price is \$5 Million Or Less. Performance Bond #1 has been approved by the U.S. Small Business Administration ("SBA") for participation in its Bond Guarantee Program.

PERFORMANCE BOND #1 (Page 1)

PERFORMANCE BOND #1

KNOW ALL PERSONS BY THESE PRESENTS;

That we, _____

hereinafter referred to as the "Principal,"
and, _____

hereinafter referred to as the "Surety" ("Sureties") are held and firmly bound to THE CITY OF NEW YORK, hereinafter referred to as the "City" or to its successors and assigns in the penal sum of _____

(\$ _____) Dollars, lawful money of the United States for the payment of which said sum of money well and truly to be made, we, and each of us, bind ourselves, our heirs, executors, administrators, successors and assigns, jointly and severally, firmly by these presents.

WHEREAS, the Principal is about to enter, or has entered, into a Contract in writing with the City for _____

a copy of which Contract is annexed to and hereby made a part of this bond as though herein set forth in full;

NOW, THEREFORE, the conditions of this obligation are such that if the Principal, his or its representatives or assigns, shall well and faithfully perform the said Contract and all modifications, amendments, additions and alterations thereto that may hereafter be made, according to its terms and its true intent and meaning, including repair and or replacement of defective work and guarantees of maintenance for the periods stated in the Contract, and shall fully indemnify and save harmless the City from all cost and damage which it may suffer by reason of the Principal's default of the Contract, and shall fully reimburse and repay the City for all outlay and expense which the City may incur in making

Performance Bond #1 (Pages 100 to 103): Use if the total contract price is \$5 Million Or Less. Performance Bond #1 has been approved by the U.S. Small Business Administration ("SBA") for participation in its Bond Guarantee Program.

PERFORMANCE BOND #1 (Page 2)

good any such default and shall protect the said City of New York against, and pay any and all amounts, damages, cost and judgments which may or shall be recovered against said City or its officers or agents or which the said City of New York may be called upon to pay any person or corporation by reason of any damages arising or growing out of the Principal's default of the Contract, then this obligation shall be null and void, otherwise to remain in full force and effect.

The Surety (Sureties), for value received, hereby stipulates and agrees, upon written notice from the City that the City has determined that the Principal is in default of the Contract, to (1) pay the City the cost to complete the contract as determined by the City in excess of the balance of the Contract held by the City, plus any damages or costs to which the City is entitled, up to the full amount of the above penal sum, (2) fully perform and complete the Work to be performed under the Contract, pursuant to the terms, conditions, and covenants thereof, or (3) tender a completion Contractor that is acceptable to the City. The Surety (Sureties) further agrees, at its option, either to notify the City that it elects to pay the city the cost of completion plus any applicable damages and costs under option (1) above, or to commence and diligently perform the Work specified in the Contract, including physical site work, within twenty-five (25) business days after written notice thereof from the City and, if the Surety elects to fully perform and complete the Work, then to complete all Work within the time set forth in the Contract or such other time as agreed to between the City and Surety in accordance with the Contract. If the Surety elects to tender payment pursuant to (1) above, then the Surety shall tender such amount within fifteen (15) business days notification from the City of the cost of completion. The Surety and the City reserve all rights and defenses each may have against the other; provided, however, that the Surety expressly agrees that its reservation of rights shall not provide a basis for non-performance of its obligation to pay the City the cost of completion, to commence and complete all Work as provided herein, or to tender a completion contractor.

The Surety (Sureties), for value received, for itself and its successors and assigns, hereby stipulates and agrees that the obligation of said Surety (Sureties) and its bond shall be in no way impaired or affected by any extension of time, modification, omission, addition, or change in or to the said Contract or the Work to be performed thereunder, or by any payment thereunder before the time required therein, or by any waiver of any provisions thereof, or any moneys due or to become due thereunder; and said Surety (Sureties) does hereby waive notice of any and all of such extensions, modifications, omissions, additions, changes, payments, and waivers, and hereby expressly stipulates and agrees that any and all things done and omitted to be done by and in relation to subcontractors shall have the same effect as to said Surety (Sureties) as though done or omitted to be done by or in relation to said Principal. Notwithstanding the above, if the City makes payments to the Principal before the time required by the contract that in the aggregate exceed \$100,000 or 10% of the Contract price, whichever is less, and that have not become earned prior to the Principal being found to be in default, then all payments made to the Principal before the time required by the Contract shall be added to the remaining contract value available to be paid for the completion of the Contract as if such sums had not been paid to the Principal, but shall not provide a basis for non-performance of its obligation to pay the City the cost of completion, to commence and to complete all Work as provided herein, or to tender a completion contractor.

Performance Bond #1 (Pages 100 to 103): Use if the total contract price is \$5 Million Or Less. Performance Bond #1 has been approved by the U.S. Small Business Administration ("SBA") for participation in its Bond Guarantee Program.

PERFORMANCE BOND #1 (Page 3)

IN WITNESS WHEREOF, The Principal and the Surety (Sureties) have hereunto set their hands and seals, and such of them as are corporations have caused their corporate seals to be hereunto affixed and these presents to be signed by their proper officers, this

_____ day of _____, 20_____

(Seal) _____ (L.S.)
Principal

(Seal) By: _____
Surety

(Seal) By: _____
Surety

(Seal) By: _____
Surety

(Seal) By: _____
Surety

(Seal) By: _____
Surety

(Seal) By: _____

Bond Premium Rate _____

Bond Premium Cost _____

If the Contractor (Principal) is a partnership, the bond should be signed by each of the individuals who are partners.

If the Contractor (Principal) is a corporation, the bond should be signed in its correct corporate name by a duly authorized officer, agent, or attorney-in-fact.

There should be executed an appropriate number of counterparts of the bond corresponding to the number of counterparts of the Contract.

Performance Bond #1 (Pages 100 to 103): Use if the total contract price is \$5 Million Or Less.
Performance Bond #1 has been approved by the U.S. Small Business Administration ("SBA")
for participation in its Bond Guarantee Program.

PERFORMANCE BOND #1 (Page 4)

ACKNOWLEDGMENT OF PRINCIPAL IF A CORPORATION

State of _____ County of _____ ss:
On this _____ day of _____, 20____ before me personally
came _____
to me known, who, being by me duly sworn did depose and say that he/she resides
at _____

_____ ; that he/she is the _____
of the corporation described in and which executed the foregoing instrument; and that he/she signed his/her name to
the foregoing instrument by order of the directors of said corporation as the duly authorized and binding act thereof.

Notary Public or Commissioner of Deeds.

ACKNOWLEDGMENT OF PRINCIPAL IF A PARTNERSHIP

State of _____ County of _____ ss:
On this _____ day of _____, 20____ before me personally
came _____
to me known, who, being by me duly sworn did depose and say that he/she resides
at _____

_____ ; that he/she is _____ partner of
_____, a limited/general partnership existing under the laws of the State of
_____, the partnership described in and which executed the foregoing instrument;
and that he/she signed his/her name to the foregoing instrument as the duly authorized and binding act of
said partnership.

Notary Public or Commissioner of Deeds.

ACKNOWLEDGMENT OF PRINCIPAL IF AN INDIVIDUAL

State of _____ County of _____ ss:
On this _____ day of _____, 20____ before me personally
came _____
to me known, who, being by me duly sworn did depose and say that he/she resides
at _____

_____, and that he/she is the individual whose name is
~~subscribed to the within instrument and acknowledged to me that by his/her signature on the~~
instrument, said individual executed the instrument.

Notary Public or Commissioner of Deeds

Each executed bond should be accompanied by: (a) appropriate acknowledgments of the respective parties; (b) appropriate
duly certified copy of Power of Attorney or other certificate of authority where bond is executed by agent, officer or other
representative of Principal or Surety; (c) a duly certified extract from By-Laws or resolutions of Surety under which Power
of Attorney or other certificate of authority of its agent, officer or representative was issued, and (d) certified copy of latest
published financial statement of assets and liabilities of Surety.

Affix Acknowledgments and Justification of Sureties.

CITY OF NEW YORK
DDC

103

STANDARD CONSTRUCTION CONTRACT
March 2017

Performance Bond #2 (Pages 104 to 107): Use if the total contract price is more than \$5 Million.

PERFORMANCE BOND #2 (Page 1)

Bond #107211337

PERFORMANCE BOND #2

KNOW ALL PERSONS BY THESE PRESENTS;

That we, ADC Construction, LLC

58-08 48th St.

Maspeth, Ny 11378

hereinafter referred to as the "Principal,"

and, Travelers Casualty & Surety Company of America

One Tower Square

Hartford, CT 06183

hereinafter referred to as the "Surety" ("Sureties") are held and firmly bound to THE CITY OF NEW YORK, hereinafter referred to as the "City" or to its successors and assigns in the penal sum of Seven Million Five Hundred Eighty Six Thousand Forty Seven and 70/100

(\$ 7,586,047.70) Dollars, lawful money of the United States for the payment of which said sum of money well and truly to be made, we, and each of us, bind ourselves, our heirs, executors, administrators, successors and assigns, jointly and severally, firmly by these presents.

WHEREAS, the Principal is about to enter, or has entered, into a Contract in writing with the City for

Cont. #SEQBN11 - E-PIN: 85020B0005001 - DDC PIN: 8502019SE0033C

Reconstruction of Existing Sewers, North Queens - Borough of Queens

a copy of which Contract is annexed to and hereby made a part of this bond as though herein set forth in full;

NOW, THEREFORE, the conditions of this obligation are such that if the Principal, his or its representatives or assigns, shall well and faithfully perform the said Contract and all modifications, amendments, additions and alterations thereto that may hereafter be made, according to its terms and its true intent and meaning, including repair and or replacement of defective work and guarantees of maintenance for the periods stated in the Contract, and shall fully indemnify and save harmless the City from all cost and damage which it may suffer by reason of the Principal's default of the Contract, and shall fully reimburse and repay the City for all outlay and expense which the City may incur in making

Performance Bond #2 (Pages 104 to 107): Use if the total contract price is more than \$5 Million.

PERFORMANCE BOND #2 (Page 2)

good any such default and shall protect the said City of New York against, and pay any and all amounts, damages, cost and judgments which may or shall be recovered against said City or its officers or agents or which the said City of New York may be called upon to pay any person or corporation by reason of any damages arising or growing out of the Principal's default of the Contract, then this obligation shall be null and void, otherwise to remain in full force and effect.

The Surety (Sureties), for value received, hereby stipulates and agrees, upon written notice from the City that the City has determined that the Principal is in default of the Contract, to either (1) pay the full amount of the above penal sum in complete discharge and exoneration of this bond and of all the liabilities of the Surety relating to this bond, or (2) fully perform and complete the Work to be performed under the Contract, pursuant to the terms, conditions, and covenants thereof. The Surety (Sureties) further agrees, at its option, either to tender the penal sum or to commence and diligently perform the Work specified in the Contract, including physical site work, within twenty-five (25) business days after written notice thereof from the City and to complete all Work within the time set forth in the Contract or such other time as agreed to between the City and Surety in accordance with the Contract. The Surety and the City reserve all rights and defenses each may have against the other; provided, however, that the Surety expressly agrees that its reservation of rights shall not provide a basis for non-performance of its obligation to commence and to complete all Work as provided herein.

The Surety (Sureties), for value received, for itself and its successors and assigns, hereby stipulates and agrees that the obligation of said Surety (Sureties) and its bond shall be in no way impaired or affected by any extension of time, modification, omission, addition, or change in or to the said Contract or the Work to be performed thereunder, or by any payment thereunder before the time required therein, or by any waiver of any provisions thereof, or by any assignment, subletting or other transfer thereof or of any Work to be performed or any moneys due or to become due thereunder; and said Surety (Sureties) does hereby waive notice of any and all of such extensions, modifications, omissions, additions, changes, payments, waivers, assignments, subcontracts and transfers, and hereby expressly stipulates and agrees that any and all things done and omitted to be done by and in relation to assignees, subcontractors, and other transferees shall have the same effect as to said Surety (Sureties) as though done or omitted to be done by or in relation to said Principal.

Performance Bond #2 (Pages 104 to 107): Use if the total contract price is more than \$5 Million.

PERFORMANCE BOND #2 (Page 3)

IN WITNESS WHEREOF, The Principal and the Surety (Sureties) have hereunto set their hands and seals, and such of them as are corporations have caused their corporate seals to be hereunto affixed and these presents to be signed by their proper officers, this

_____ 1st _____ day of June _____ 20 20 _____
(Seal)

ADC Construcion, LLC (L.S.)
Principal

By: *David [Signature]*

(Seal)

Surety

By: _____
Travelers Casualty & Surety Company of America

(Seal)

Surety

By: *Robert M. Kempner*
Robert M. Kempner, Attorney-In-Fact

(Seal)

Surety

By: _____

(Seal)

Surety

By: _____

(Seal)

Surety

By: _____

Bond Premium Rate _____

Bond Premium Cost _____

If the Contractor (Principal) is a partnership, the bond should be signed by each of the individuals who are partners.

If the Contractor (Principal) is a corporation, the bond should be signed in its correct corporate name by a duly authorized officer, agent, or attorney-in-fact.

There should be executed an appropriate number of counterparts of the bond corresponding to the number of counterparts of the Contract.

Performance Bond #2 (Pages 104 to 107): Use if the total contract price is more than \$5 Million.

PERFORMANCE BOND #2 (Page 4)

ACKNOWLEDGMENT OF PRINCIPAL IF A CORPORATION

State of _____ County of _____ ss:

On this _____ day of _____, 20 _____ before me personally came _____ to me known, who, being by me duly sworn did depose and say that he resides at _____

_____ ; that he/she is the _____ of the corporation described in and which executed the foregoing instrument; that he/she signed his/her name to the foregoing instrument by order of the directors of said corporation as the duly authorized and binding act thereof.

Notary Public or Commissioner of Deeds.

ACKNOWLEDGMENT OF PRINCIPAL IF A PARTNERSHIP

State of NEW YORK County of QUEENS ss:

On this 3rd day of JUNE, 20 20 before me personally came DOMENICK CIPOLLONE to me known, who, being by me duly sworn did depose and say that he/she resides at HASTINGS NY

_____ ; that he/she is PRESIDENT partner of ADC CONSTRUCTION, a limited/general partnership existing under the laws of the State of _____, the partnership described in and which executed the foregoing instrument; and that he/she signed his/her name to the foregoing instrument as the duly authorized and binding act of said partnership.

Melissa Gallagher
Notary Public or Commissioner of Deeds

MELISSA GALLAGHER
NOTARY PUBLIC, STATE OF NEW YORK
Registration No. 01GA6013314
Qualified in Queens County
Commission Expires 09-14-2022

ACKNOWLEDGMENT OF PRINCIPAL IF AN INDIVIDUAL

State of _____ County of _____ ss:

On this _____ day of _____, 20 _____ before me personally came _____ to me known, who, being by me duly sworn did depose and say that he/she resides at _____

_____ and that he/she is the individual whose name is subscribed to the within instrument and acknowledged to me that by his/her signature on the instrument, said individual executed the instrument.

Notary Public or Commissioner of Deeds

Each executed bond should be accompanied by: (a) appropriate acknowledgments of the respective parties; (b) appropriate duly certified copy of Power of Attorney or other certificate of authority where bond is executed by agent, officer or other representative of Principal or Surety; (c) a duly certified extract from By-Laws or resolutions of Surety under which Power of Attorney or other certificate of authority of its agent, officer or representative was issued, and (d) certified copy of latest published financial statement of assets and liabilities of Surety.

Affix Acknowledgments and Justification of Sureties.



**Travelers Casualty and Surety Company of America
Travelers Casualty and Surety Company
St. Paul Fire and Marine Insurance Company**

POWER OF ATTORNEY

KNOW ALL MEN BY THESE PRESENTS: That Travelers Casualty and Surety Company of America, Travelers Casualty and Surety Company, and St. Paul Fire and Marine Insurance Company are corporations duly organized under the laws of the State of Connecticut (herein collectively called the "Companies"), and that the Companies do hereby make, constitute and appoint **Robert M. Kempner of Plainview, New York**, their true and lawful Attorney-in-Fact to sign, execute, seal and acknowledge any and all bonds, recognizances, conditional undertakings and other writings obligatory in the nature thereof on behalf of the Companies in their business of guaranteeing the fidelity of persons, guaranteeing the performance of contracts and executing or guaranteeing bonds and undertakings required or permitted in any actions or proceedings allowed by law.

IN WITNESS WHEREOF, the Companies have caused this instrument to be signed, and their corporate seals to be hereto affixed, this **3rd** day of **February**, 2017.



State of Connecticut

City of Hartford ss.

By: 
Robert L. Raney, Senior Vice President

On this the **3rd** day of **February**, 2017, before me personally appeared **Robert L. Raney**, who acknowledged himself to be the Senior Vice President of Travelers Casualty and Surety Company of America, Travelers Casualty and Surety Company, and St. Paul Fire and Marine Insurance Company, and that he, as such, being authorized so to do, executed the foregoing instrument for the purposes therein contained by signing on behalf of the corporations by himself as a duly authorized officer.

In Witness Whereof, I hereunto set my hand and official seal.

My Commission expires the **30th** day of **June**, 2021



Marie C. Tetreault, Notary Public

This Power of Attorney is granted under and by the authority of the following resolutions adopted by the Boards of Directors of Travelers Casualty and Surety Company of America, Travelers Casualty and Surety Company, and St. Paul Fire and Marine Insurance Company, which resolutions are now in full force and effect, reading as follows:

RESOLVED, that the Chairman, the President, any Vice Chairman, any Executive Vice President, any Senior Vice President, any Vice President, any Second Vice President, the Treasurer, any Assistant Treasurer, the Corporate Secretary or any Assistant Secretary may appoint Attorneys-in-Fact and Agents to act for and on behalf of the Company and may give such appointee such authority as his or her certificate of authority may prescribe to sign with the Company's name and seal with the Company's seal bonds, recognizances, contracts of indemnity, and other writings obligatory in the nature of a bond, recognizance, or conditional undertaking, and any of said officers or the Board of Directors at any time may remove any such appointee and revoke the power given him or her; and it is

FURTHER RESOLVED, that the Chairman, the President, any Vice Chairman, any Executive Vice President, any Senior Vice President or any Vice President may delegate all or any part of the foregoing authority to one or more officers or employees of this Company, provided that each such delegation is in writing and a copy thereof is filed in the office of the Secretary; and it is

FURTHER RESOLVED, that any bond, recognizance, contract of indemnity, or writing obligatory in the nature of a bond, recognizance, or conditional undertaking shall be valid and binding upon the Company when (a) signed by the President, any Vice Chairman, any Executive Vice President, any Senior Vice President or any Vice President, any Assistant Treasurer, the Treasurer, any Assistant Treasurer, the Corporate Secretary or any Assistant Secretary and duly attested and sealed with the Company's seal by a Secretary or Assistant Secretary; or (b) duly executed (under seal, if required) by one or more Attorneys-in-Fact and Agents pursuant to the power prescribed in his or her certificate or their certificates of authority or by one or more Company officers pursuant to a written delegation of authority; and it is

FURTHER RESOLVED, that the signature of each of the following officers: President, any Executive Vice President, any Senior Vice President, any Vice President, any Assistant Vice President, any Secretary, any Assistant Secretary, and the seal of the Company may be affixed by facsimile to any Power of Attorney or to any certificate relating thereto appointing Resident Vice Presidents, Resident Assistant Secretaries or Attorneys-in-Fact for purposes only of executing and attesting bonds and undertakings and other writings obligatory in the nature thereof, and any such Power of Attorney or certificate bearing such facsimile signature or facsimile seal shall be valid and binding upon the Company and any such power so executed and certified by such facsimile signature and facsimile seal shall be valid and binding on the Company in the future with respect to any bond or understanding to which it is attached.

I, **Kevin E. Hughes**, the undersigned, Assistant Secretary of Travelers Casualty and Surety Company of America, Travelers Casualty and Surety Company, and St. Paul Fire and Marine Insurance Company, do hereby certify that the above and foregoing is a true and correct copy of the Power of Attorney executed by said Companies, which remains in full force and effect.

Dated this 1st day of June, 2020



Kevin E. Hughes, Assistant Secretary

**To verify the authenticity of this Power of Attorney, please call us at 1-800-421-3880.
Please refer to the above-named Attorney-in-Fact and the details of the bond to which the power is attached.**

TRAVELERS CASUALTY AND SURETY COMPANY OF AMERICA

HARTFORD, CT 06183

PRINCIPAL'S ACKNOWLEDGMENT

State of _____, County of _____ }ss.

On this _____ day of _____ in the year 20____, before me, the undersigned, personally appeared _____, personally known to me or proved to me on the basis of satisfactory evidence to be the individual whose name is subscribed to the within instrument and acknowledged to me that he/she executed the same in his/her capacity, and that by his/her signature on the instrument, the individual, or the person upon behalf of which the individual acted, executed the instrument.

Notary Public

SURETY COMPANY'S ACKNOWLEDGMENT

State of New York, County of Nassau }ss.

On this 1st day of June in the year 20 20, before me, the undersigned, personally appeared Robert M. Kempner, personally known to me, and who, being by me duly sworn, did depose and say: That he/she resides in Centerport, NY; that he/she is Attorney-in-Fact of **TRAVELERS CASUALTY AND SURETY COMPANY OF AMERICA**, the corporation described in and which executed the within instrument; that he/she knows the corporate seal of said Company; that the seal affixed to said instrument is such corporate seal; and that he/she signed said instrument as Attorney-in-Fact by authority of the Board of Directors of said Company; and affiant did further depose and say that the Superintendent of the State of New York Department of Financial Services has, pursuant to Section 1111 of the New York Insurance Law, issued to **TRAVELERS CASUALTY AND SURETY COMPANY OF AMERICA** his/her certificate that said Company is qualified to become and be accepted as surety or guarantor on all bonds, undertakings, recognizances, guaranties, and other obligations required or permitted by law; and that such certificate has not been revoked.



Notary Public

HARTFORD, CONNECTICUT 06183

FINANCIAL STATEMENT AS OF DECEMBER 31, 2019

AS FILED IN THE STATE OF NEW YORK

CAPITAL STOCK \$ 6,480,000

LYNN ANN INFANTI
Notary Public, State of New York
No. 011N6004351
Qualified in Suffolk County 2022
Commission Expires March 23, 2022

ASSETS		LIABILITIES & SURPLUS	
CASH AND INVESTED CASH	\$ 90,238,215	UNEARNED PREMIUMS	\$ 1,079,715,557
BONDS	3,590,884,327	LOSSES	772,047,572
STOCKS	297,933,044	LOSS ADJUSTMENT EXPENSES	174,714,866
INVESTMENT INCOME DUE AND ACCRUED	37,250,410	COMMISSIONS	46,970,467
OTHER INVESTED ASSETS	3,986,514	TAXES, LICENSES AND FEES	14,728,588
PREMIUM BALANCES	263,364,263	OTHER EXPENSES	43,134,646
NET DEFERRED TAX ASSET	52,134,926	CURRENT FEDERAL AND FOREIGN INCOME TAXES	12,674,197
REINSURANCE RECOVERABLE	31,203,529	REMITTANCES AND ITEMS NOT ALLOCATED	17,964,746
SECURITIES LENDING REINVESTED COLLATERAL ASSETS	3,732,602	AMOUNTS WITHHELD / RETAINED BY COMPANY FOR OTHERS	26,565,278
RECEIVABLES FROM PARENT, SUBSIDIARIES AND AFFILIATES	11,831,826	RETROACTIVE REINSURANCE RESERVE ASSUMED	826,255
ASSUMED REINSURANCE RECEIVABLE AND PAYABLE	567,396	POLICYHOLDER DIVIDENDS	11,482,845
OTHER ASSETS	3,574,968	PROVISION FOR REINSURANCE	9,837,205
		ADVANCE PREMIUM	2,140,883
		PAYABLE FOR SECURITIES LENDING	3,732,602
		CEDED REINSURANCE NET PREMIUMS PAYABLE	46,059,812
		OTHER ACCRUED EXPENSES AND LIABILITIES	421,937
		TOTAL LIABILITIES	\$ 2,263,017,456
		CAPITAL STOCK	\$ 6,480,000
		PAID IN SURPLUS	433,803,760
		OTHER SURPLUS	1,683,400,804
		TOTAL SURPLUS TO POLICYHOLDERS	\$ 2,123,684,564
TOTAL ASSETS	\$ 4,386,702,020	TOTAL LIABILITIES & SURPLUS	\$ 4,386,702,020

Payment Bond (Pages 108 to 111): Use for any contract for which a Payment Bond is required.

PAYMENT BOND (Page 1)

PAYMENT BOND

Bond #107211337

KNOW ALL PERSONS BY THESE PRESENTS, That we, _____

ADC Construction, LLC _____

58-08 48th Street _____

Maspeth, NY 11378 _____

hereinafter referred to as the "Principal", and _____

Travelers Casualty & Surety Company of America _____

One Tower Square _____

Hartford, CT 06183 _____

hereinafter referred to as the "Surety" ("Sureties") are held and firmly bound to THE CITY OF NEW YORK, hereinafter referred to as the "City" or to its successors and assigns, in the penal sum of

Seven Million five Hundred Eighty Six Thousand Forty Seven and 70/100 _____

(\$ 7,586,047.70) Dollars, lawful money of the United States, for the payment of which said sum of money well and truly to be made, we, and each of us, bind ourselves, our heirs, executors, administrators, successors and assigns, jointly and severally, firmly by these presents.

WHEREAS, the Principal is about to enter, or has entered, into a Contract in writing with the City for

Cont. #SEQBN11 - E-PIN: 85020B0005001 - DDC PIN: 8502019SE0033C _____

Reconstruction of Existing Sewers, North Queens - Borough of Queens _____

a copy of which Contract is annexed to and hereby made a part of this bond as though herein set forth in full;

NOW, THEREFORE, the conditions of this obligation are such that if the Principal, his or its representatives or assigns and other Subcontractors to whom Work under this Contract is sublet and his or their successors and assigns shall promptly pay or cause to be paid all lawful claims for

(a) Wages and compensation for labor performed and services rendered by all persons engaged in the prosecution of the Work under said Contract, and any amendment or extension thereof or addition thereto, whether such persons be agents servants or employees of the Principal or any such Subcontractor, including all persons so engaged who perform the work of laborers or mechanics at or in the vicinity of the site

Payment Bond (Pages 108 to 111): Use for any contract for which a Payment Bond is required.

PAYMENT BOND (Page 2)

of the Project regardless of any contractual relationship between the Principal or such Subcontractors, or his or their successors or assigns, on the one hand and such laborers or mechanics on the other, but not including office employees not regularly stationed at the site of the project; and

(b) Materials and supplies (whether incorporated in the permanent structure or not), as well as teams, fuels, oils, implements or machinery furnished, used or consumed by said Principal or any subcontractor at or in the vicinity of the site of the Project in the prosecution of the Work under said Contract and any amendment or extension thereof or addition thereto; then this obligation shall be void, otherwise to remain in full force and effect.

This bond is subject to the following additional conditions, limitations and agreements:

(a) The Principal and Surety (Sureties) agree that this bond shall be for the benefit of any materialmen or laborer having a just claim, as well as the City itself.

(b) All persons who have performed labor, rendered services or furnished materials and supplies, as aforesaid, shall have a direct right of action against the Principal and his, its or their successors and assigns, and the Surety (Sureties) herein, or against either or both or any of them and their successors and assigns. Such persons may sue in their own name, and may prosecute the suit to judgment and execution without the necessity of joining with any other persons as party plaintiff.

(c) The Principal and Surety (Sureties) agree that neither of them will hold the City liable for any judgment for costs of otherwise, obtained by either or both of them against a laborer or materialman in a suit brought by either a laborer or materialman under this bond for moneys allegedly due for performing work or furnishing material.

(d) The Surety (Sureties) or its successors and assigns shall not be liable for any compensation recoverable by an employee or laborer under the Workmen's Compensation Law.

(e) In no event shall the Surety (Sureties), or its successors or assigns, be liable for a greater sum than the penalty of this bond or be subject to any suit, action or proceeding hereon that is instituted by any person, firm, or corporation hereunder later than two years after the complete performance of said Contract and final settlement thereof.

The Principal, for himself and his successors and assigns, and the Surety (Sureties), for itself and its successors and assigns, do hereby expressly waive any objection that might be interposed as to the right of the City to require a bond containing the foregoing provisions, and they do hereby further expressly waive any defense which they or either of them might interpose to an action brought hereon by any person, firm or corporation, including subcontractors, materialmen and third persons, for work, labor, services, supplies or material performed rendered, or furnished as aforesaid upon the ground that there is no law authorizing the City to require the foregoing provisions to be placed in this bond.

And the Surety (Sureties), for value received, for itself and its successors and assigns, hereby stipulates and agrees that the obligation of said Surety (Sureties), and its bonds shall be in no way impaired or affected by any extension of time, modification, omission, addition, or change in or of the said Contract or the work to be performed thereunder, or by any payment thereunder before the time required therein, or by any waiver of any provisions thereof, or by any assignment, subletting or other transfer thereof or of any part thereof, or of any Work to be performed, or any moneys due to become due thereunder and said Surety (Sureties) does hereby waive notice of any and all of such extensions, modifications, omissions, additions, changes, payments, waivers, assignments, subcontracts and transfers, and hereby expressly stipulates and agrees that any and all things done and omitted to be done by and in relation to assignees, Subcontractors, and other transferees shall have the same effect as to said Surety (Sureties) as though done or omitted to be done or in relation to said Principal.

Payment Bond (Pages 108 to 111): Use for any contract for which a Payment Bond is required.

PAYMENT BOND (Page 3)

IN WITNESS WHEREOF, the Principal and the Surety (Sureties) have hereunto set their hands and seals, and such of them as are corporations have caused their corporate seals to be hereunto affixed and these presents to be signed by their proper officers, this 1st day of June, 2020.

(Seal)

ADC Construction, LLC (L.S.)
Principal

By: *[Signature]*

(Seal)

Travelers Casualty & Surety Company of America
Surety

By: *[Signature]*
Robert M. Kempner, Attorney-In-Fact

(Seal)

Surety

By: _____

(Seal)

Surety

By: _____

(Seal)

Surety

By: _____

If the Contractor (Principal) is a partnership, the bond should be signed by each of the individuals who are partners.

If the Contractor (Principal) is a corporation, the bond should be signed in its correct corporate name by a duly authorized officer, agent, or attorney-in-fact.

There should be executed an appropriate number of counterparts of the bond corresponding to the number of counterparts of the Contract.

Payment Bond (Pages 108 to 111): Use for any contract for which a Payment Bond is required.

PAYMENT BOND (Page 4)

ACKNOWLEDGMENT OF PRINCIPAL, IF A CORPORATION

State of _____ County of _____ ss:

On this _____ day of _____, before me personally came _____ to me known, who, being by me duly sworn did depose and say that he resides at _____ that he is the _____ of the corporation described in and which executed the foregoing instrument; that he knows the seal of said corporation; that one of the seals affixed to said instrument is such seal; that it was so affixed by order of the directors of said corporation, and that he signed his name thereto by like order.

Notary Public or Commissioner of Deeds

LLC

ACKNOWLEDGMENT OF PRINCIPAL, IF A PARTNERSHIP

State of NEW YORK County of QUEENS ss:

On this 3rd day of June, 2020, before me personally appeared DOMENICK Cipollone to me known, and known to me to be one of the members of the firm of ADC CONSTRUCTION described in and who executed the foregoing instrument; and he acknowledged to me that he executed the same as and for the act and deed of said firm.

Melissa Gallagher

Notary Public or Commissioner of Deeds

MELISSA GALLAGHER
NOTARY PUBLIC, STATE OF NEW YORK
Registration No. 01GA6013314
Qualified in Queens County
Commission Expires 09-14-2022

ACKNOWLEDGMENT OF PRINCIPAL, IF AN INDIVIDUAL

State of _____ County of _____ ss:

On this _____ day of _____, before me personally appeared _____ to me known, and known to me to be the person described in and who executed the foregoing instrument; and acknowledged that he executed the same.

Notary Public or Commissioner of Deeds

Each executed bond should be accompanied by: (a) appropriate acknowledgments of the respective parties; (b) appropriate duly certified copy of Power of Attorney or other certificate of authority where bond is executed by agent, officer or other representative of Principal or Surety; (c) a duly certified extract from By-Laws or resolutions of Surety under which Power of Attorney or other certificate of authority of its agent, officer or representative was issued, and (d) certified copy of latest published financial statement of assets and liabilities of Surety.

Affix Acknowledgments and Justification of Sureties.



**Travelers Casualty and Surety Company of America
Travelers Casualty and Surety Company
St. Paul Fire and Marine Insurance Company**

POWER OF ATTORNEY

KNOW ALL MEN BY THESE PRESENTS: That Travelers Casualty and Surety Company of America, Travelers Casualty and Surety Company, and St. Paul Fire and Marine Insurance Company are corporations duly organized under the laws of the State of Connecticut (herein collectively called the "Companies"), and that the Companies do hereby make, constitute and appoint **Robert M. Kempner of Plainview, New York**, their true and lawful Attorney-in-Fact to sign, execute, seal and acknowledge any and all bonds, recognizances, conditional undertakings and other writings obligatory in the nature thereof on behalf of the Companies in their business of guaranteeing the fidelity of persons, guaranteeing the performance of contracts and executing or guaranteeing bonds and undertakings required or permitted in any actions or proceedings allowed by law.

IN WITNESS WHEREOF, the Companies have caused this instrument to be signed, and their corporate seals to be hereto affixed, this **3rd** day of **February**, 2017.



State of Connecticut
City of Hartford ss.

By:
Robert L. Raney, Senior Vice President

On this the **3rd** day of **February**, 2017, before me personally appeared **Robert L. Raney**, who acknowledged himself to be the Senior Vice President of Travelers Casualty and Surety Company of America, Travelers Casualty and Surety Company, and St. Paul Fire and Marine Insurance Company, and that he, as such, being authorized so to do, executed the foregoing instrument for the purposes therein contained by signing on behalf of the corporations by himself as a duly authorized officer.

In Witness Whereof, I hereunto set my hand and official seal.

My Commission expires the **30th** day of **June**, 2021



Marie C. Tetreault, Notary Public

This Power of Attorney is granted under and by the authority of the following resolutions adopted by the Boards of Directors of Travelers Casualty and Surety Company of America, Travelers Casualty and Surety Company, and St. Paul Fire and Marine Insurance Company, which resolutions are now in full force and effect, reading as follows:

RESOLVED, that the Chairman, the President, any Vice Chairman, any Executive Vice President, any Senior Vice President, any Vice President, any Second Vice President, the Treasurer, any Assistant Treasurer, the Corporate Secretary or any Assistant Secretary may appoint Attorneys-in-Fact and Agents to act for and on behalf of the Company and may give such appointee such authority as his or her certificate of authority may prescribe to sign with the Company's name and seal with the Company's seal bonds, recognizances, contracts of indemnity, and other writings obligatory in the nature of a bond, recognizance, or conditional undertaking, and any of said officers or the Board of Directors at any time may remove any such appointee and revoke the power given him or her; and it is

FURTHER RESOLVED, that the Chairman, the President, any Vice Chairman, any Executive Vice President, any Senior Vice President or any Vice President may delegate all or any part of the foregoing authority to one or more officers or employees of this Company, provided that each such delegation is in writing and a copy thereof is filed in the office of the Secretary; and it is

FURTHER RESOLVED, that any bond, recognizance, contract of indemnity, or writing obligatory in the nature of a bond, recognizance, or conditional undertaking shall be valid and binding upon the Company when (a) signed by the President, any Vice Chairman, any Executive Vice President, any Senior Vice President or any Vice President, any Second Vice President, the Treasurer, any Assistant Treasurer, the Corporate Secretary or any Assistant Secretary and duly attested and sealed with the Company's seal by a Secretary or Assistant Secretary; or (b) duly executed (under seal, if required) by one or more Attorneys-in-Fact and Agents pursuant to the power prescribed in his or her certificate or their certificates of authority or by one or more Company officers pursuant to a written delegation of authority; and it is

FURTHER RESOLVED, that the signature of each of the following officers: President, any Executive Vice President, any Senior Vice President, any Vice President, any Assistant Vice President, any Secretary, any Assistant Secretary, and the seal of the Company may be affixed by facsimile to any Power of Attorney or to any certificate relating thereto appointing Resident Vice Presidents, Resident Assistant Secretaries or Attorneys-in-Fact for purposes only of executing and attesting bonds and undertakings and other writings obligatory in the nature thereof, and any such Power of Attorney or certificate bearing such facsimile signature or facsimile seal shall be valid and binding upon the Company and any such power so executed and certified by such facsimile signature and facsimile seal shall be valid and binding on the Company in the future with respect to any bond or understanding to which it is attached.

I, **Kevin E. Hughes**, the undersigned, Assistant Secretary of Travelers Casualty and Surety Company of America, Travelers Casualty and Surety Company, and St. Paul Fire and Marine Insurance Company, do hereby certify that the above and foregoing is a true and correct copy of the Power of Attorney executed by said Companies, which remains in full force and effect.

Dated this 1st day of June, 2020



Kevin E. Hughes, Assistant Secretary

**To verify the authenticity of this Power of Attorney, please call us at 1-800-421-3880.
Please refer to the above-named Attorney-in-Fact and the details of the bond to which the power is attached.**

TRAVELERS CASUALTY AND SURETY COMPANY OF AMERICA

HARTFORD, CT 06183

PRINCIPAL'S ACKNOWLEDGMENT

State of _____, County of _____ }ss.

On this _____ day of _____ in the year 20____, before me, the undersigned, personally appeared _____, personally known to me or proved to me on the basis of satisfactory evidence to be the individual whose name is subscribed to the within instrument and acknowledged to me that he/she executed the same in his/her capacity, and that by his/her signature on the instrument, the individual, or the person upon behalf of which the individual acted, executed the instrument.

Notary Public

SURETY COMPANY'S ACKNOWLEDGMENT

State of New York, County of Nassau }ss.

On this 1st day of June in the year 20 20, before me, the undersigned, personally appeared Robert M. Kempner, personally known to me, and who, being by me duly sworn, did depose and say: That he/she resides in Centerport, NY; that he/she is Attorney-in-Fact of **TRAVELERS CASUALTY AND SURETY COMPANY OF AMERICA**, the corporation described in and which executed the within instrument; that he/she knows the corporate seal of said Company; that the seal affixed to said instrument is such corporate seal; and that he/she signed said instrument as Attorney-in-Fact by authority of the Board of Directors of said Company; and affiant did further depose and say that the Superintendent of the State of New York Department of Financial Services has, pursuant to Section 1111 of the New York Insurance Law, issued to **TRAVELERS CASUALTY AND SURETY COMPANY OF AMERICA** his/her certificate that said Company is qualified to become and be accepted as surety or guarantor on all bonds, undertakings, recognizances, guaranties, and other obligations required or permitted by law; and that such certificate has not been revoked.

L

Notary Public

HARTFORD, CONNECTICUT 06183
FINANCIAL STATEMENT AS OF DECEMBER 31, 2019
AS FILED IN THE STATE OF NEW YORK
CAPITAL STOCK \$ 6,480,000

LYNN ANN INFANTI
Notary Public, State of New York
No. 011N6004351
Qualified in Suffolk County *2020*
Commission Expires March 23, *2022*

ASSETS		LIABILITIES & SURPLUS	
CASH AND INVESTED CASH	\$ 90,238,215	UNEARNED PREMIUMS	\$ 1,079,715,557
BONDS	3,590,884,327	LOSSES	772,047,572
STOCKS	297,933,044	LOSS ADJUSTMENT EXPENSES	174,714,866
INVESTMENT INCOME DUE AND ACCRUED	37,250,410	COMMISSIONS	46,970,467
OTHER INVESTED ASSETS	3,986,514	TAXES, LICENSES AND FEES	14,728,588
PREMIUM BALANCES	263,364,263	OTHER EXPENSES	43,134,646
NET DEFERRED TAX ASSET	52,134,926	CURRENT FEDERAL AND FOREIGN INCOME TAXES	12,674,197
REINSURANCE RECOVERABLE	31,203,529	REMITTANCES AND ITEMS NOT ALLOCATED	17,964,746
SECURITIES LENDING REINVESTED COLLATERAL ASSETS	3,732,602	AMOUNTS WITHHELD / RETAINED BY COMPANY FOR OTHERS	26,565,278
RECEIVABLES FROM PARENT, SUBSIDIARIES AND AFFILIATES	11,831,826	RETROACTIVE REINSURANCE RESERVE ASSUMED	826,255
ASSUMED REINSURANCE RECEIVABLE AND PAYABLE	567,396	POLICYHOLDER DIVIDENDS	11,482,845
OTHER ASSETS	3,574,968	PROVISION FOR REINSURANCE	9,837,205
		ADVANCE PREMIUM	2,140,883
		PAYABLE FOR SECURITIES LENDING	3,732,602
		CEDED REINSURANCE NET PREMIUMS PAYABLE	46,059,812
		OTHER ACCRUED EXPENSES AND LIABILITIES	421,937
		TOTAL LIABILITIES	\$ 2,263,017,456
		CAPITAL STOCK	\$ 6,480,000
		PAID IN SURPLUS	433,803,760
		OTHER SURPLUS	1,683,400,804
		TOTAL SURPLUS TO POLICYHOLDERS	\$ 2,123,684,564
TOTAL ASSETS	\$ 4,386,702,020	TOTAL LIABILITIES & SURPLUS	\$ 4,386,702,020

THIS ENDORSEMENT CHANGES THE POLICY. PLEASE READ IT CAREFULLY.

ADDITIONAL INSURED – OWNERS, LESSEES OR CONTRACTORS – COMPLETED OPERATIONS

This endorsement modifies insurance provided under the following:

COMMERCIAL GENERAL LIABILITY COVERAGE PART
PRODUCTS/COMPLETED OPERATIONS LIABILITY COVERAGE PART.

SCHEDULE

Name Of Additional Insured Person(s) Or Organization(s)	Location And Description Of Completed Operations
The City of New York, including its officials and employees.	FMS ID: SEQBN11, E-Pin: 85020B0005001, DDC Pin: 8502019SE0033C, Reconstruction of Existing Sewers, North Queens
Information required to complete this Schedule, if not shown above, will be shown in the Declarations.	

A. Section II – Who Is An Insured is amended to include as an additional insured the person(s) or organization(s) shown in the Schedule, but only with respect to liability for "bodily injury" or "property damage" caused, in whole or in part, by "your work" at the location designated and described in the Schedule of this endorsement performed for that additional insured and included in the "products-completed operations hazard".

However:

1. The insurance afforded to such additional insured only applies to the extent permitted by law; and
2. If coverage provided to the additional insured is required by a contract or agreement, the insurance afforded to such additional insured will not be broader than that which you are required by the contract or agreement to provide for such additional insured.

B. With respect to the insurance afforded to these additional insureds, the following is added to Section III – Limits Of Insurance:

If coverage provided to the additional insured is required by a contract or agreement, the most we will pay on behalf of the additional insured is the amount of insurance:

1. Required by the contract or agreement; or
2. Available under the applicable Limits of Insurance shown in the Declarations;

whichever is less.

This endorsement shall not increase the applicable Limits of Insurance shown in the Declarations.

THIS ENDORSEMENT CHANGES THE POLICY. PLEASE READ IT CAREFULLY.

ADDITIONAL INSURED – DESIGNATED PERSON OR ORGANIZATION

This endorsement modifies insurance provided under the following:

COMMERCIAL GENERAL LIABILITY COVERAGE PART

SCHEDULE

Name Of Additional Insured Person(s) Or Organization(s)
National Grid and Consolidated Edison
Job: FMS ID: SEQBN11
Information required to complete this Schedule, if not shown above, will be shown in the Declarations.

A. Section II – Who Is An Insured is amended to include as an additional insured the person(s) or organization(s) shown in the Schedule, but only with respect to liability for "bodily injury", "property damage" or "personal and advertising injury" caused, in whole or in part, by your acts or omissions or the acts or omissions of those acting on your behalf:

1. In the performance of your ongoing operations; or
2. In connection with your premises owned by or rented to you.

However:

1. The insurance afforded to such additional insured only applies to the extent permitted by law; and
2. If coverage provided to the additional insured is required by a contract or agreement, the

insurance afforded to such additional insured will not be broader than that which you are required by the contract or agreement to provide for such additional insured.

B. With respect to the insurance afforded to these additional insureds, the following is added to Section III – Limits Of Insurance:

If coverage provided to the additional insured is required by a contract or agreement, the most we will pay on behalf of the additional insured is the amount of insurance:

1. Required by the contract or agreement; or
 2. Available under the applicable Limits of Insurance shown in the Declarations;
- whichever is less.

This endorsement shall not increase the applicable Limits of Insurance shown in the Declarations.

NOTICE: THESE POLICY FORMS AND THE APPLICABLE RATES ARE EXEMPT FROM THE FILING REQUIREMENTS OF THE NEW YORK INSURANCE LAW AND REGULATIONS. HOWEVER, THE FORMS AND RATES MUST MEET THE MINIMUM STANDARDS OF THE NEW YORK INSURANCE LAW AND REGULATIONS.

THIS ENDORSEMENT CHANGES THE POLICY. PLEASE READ IT CAREFULLY.

**ADDITIONAL INSURED – OWNERS, LESSEES OR
CONTRACTORS – SCHEDULED PERSON OR
ORGANIZATION**

This endorsement modifies insurance provided under the following:

COMMERCIAL GENERAL LIABILITY COVERAGE PART

SCHEDULE

Name Of Additional Insured Person(s) Or Organization(s)	Location(s) Of Covered Operations
The City of New York, including its officials and employees.	FMS ID: SEQBN11, E-Pin: 85020B0005001, DDC Pin: 8502019SE0033C, Reconstruction of Existing Sewers, North Queens
Information required to complete this Schedule, if not shown above, will be shown in the Declarations.	

A. Section II – Who Is An Insured is amended to include as an additional insured the person(s) or organization(s) shown in the Schedule, but only with respect to liability for "bodily injury", "property damage" or "personal and advertising injury" caused, in whole or in part, by:

1. Your acts or omissions; or
2. The acts or omissions of those acting on your behalf;

in the performance of your ongoing operations for the additional insured(s) at the location(s) designated above.

However:

1. The insurance afforded to such additional insured only applies to the extent permitted by law; and
2. If coverage provided to the additional insured is required by a contract or agreement, the insurance afforded to such additional insured will not be broader than that which you are required by the contract or agreement to provide for such additional insured.

B. With respect to the insurance afforded to these additional insureds, the following additional exclusions apply:

This insurance does not apply to "bodily injury" or "property damage" occurring after:

1. All work, including materials, parts or equipment furnished in connection with such work, on the project (other than service, maintenance or repairs) to be performed by or on behalf of the additional insured(s) at the location of the covered operations has been completed; or
2. That portion of "your work" out of which the injury or damage arises has been put to its intended use by any person or organization other than another contractor or subcontractor engaged in performing operations for a principal as a part of the same project.

C. With respect to the insurance afforded to these additional insureds, the following is added to **Section III – Limits Of Insurance:**

If coverage provided to the additional insured is required by a contract or agreement, the most we will pay on behalf of the additional insured is the amount of insurance:

1. Required by the contract or agreement; or

2. Available under the applicable Limits of Insurance shown in the Declarations;
whichever is less.

This endorsement shall not increase the applicable Limits of Insurance shown in the Declarations.



Workers' Compensation Board

**CERTIFICATE OF
NYS WORKERS' COMPENSATION INSURANCE COVERAGE**

<p>1a. Legal Name & Address of Insured (use street address only) ADC Construction LLC 58-08 48th Street Maspeth, NY 11378</p> <p>Work Location of Insured (Only required if coverage is specifically limited to certain locations in New York State, i.e., a Wrap-Up Policy)</p>	<p>1b. Business Telephone Number of Insured 718-628-5555</p> <p>1c. NYS Unemployment Insurance Employer Registration Number of Insured</p> <p>1d. Federal Employer Identification Number of Insured or Social Security Number 11-3353007</p>
<p>2. Name and Address of Entity Requesting Proof of Coverage (Entity Being Listed as the Certificate Holder)</p> <p>City of New York Department of Design and Construction 30-30 Thomson Ave Long Island City, NY 11101</p>	<p>3a. Name of Insurance Carrier Starr Indemnity & Liability Co.</p> <p>3b. Policy Number of Entity Listed in Box "1a" 1000001321</p> <p>3c. Policy effective period 10/18/2019 to 10/18/2020</p> <p>3d. The Proprietor, Partners or Executive Officers are <input type="checkbox"/> included. (Only check box if all partners/officers included) <input checked="" type="checkbox"/> all excluded or certain partners/officers excluded.</p>

This certifies that the insurance carrier indicated above in box "3" insures the business referenced above in box "1a" for workers' compensation under the New York State Workers' Compensation Law. **(To use this form, New York (NY) must be listed under Item 3A on the INFORMATION PAGE of the workers' compensation insurance policy).** The Insurance Carrier or its licensed agent will send this Certificate of Insurance to the entity listed above as the certificate holder in box "2".

Will the carrier notify the certificate holder within 10 days of a policy being cancelled for non-payment of premium or within 30 days if cancelled for any other reason or if the insured is otherwise eliminated from the coverage indicated on this certificate prior to the end of the policy effective period? YES NO

This certificate is issued as a matter of information only and confers no rights upon the certificate holder. This certificate does not amend, extend or alter the coverage afforded by the policy listed, nor does it confer any rights or responsibilities beyond those contained in the referenced policy.

This certificate may be used as evidence of a Workers' Compensation contract of insurance only while the underlying policy is in effect.

Please Note: Upon cancellation of the workers' compensation policy indicated on this form, if the business continues to be named on a permit, license or contract issued by a certificate holder, the business must provide that certificate holder with a new Certificate of Workers' Compensation Coverage or other authorized proof that the business is complying with the mandatory coverage requirements of the New York State Workers' Compensation Law.

Under penalty of perjury, I certify that I am an authorized representative or licensed agent of the insurance carrier referenced above and that the named insured has the coverage as depicted on this form.

Approved by: Robin Burger
(Print name of authorized representative or licensed agent of insurance carrier)

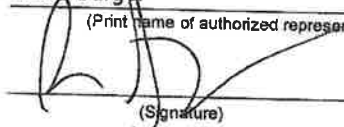
Approved by: 
(Signature)

6/2/2020
(Date)

Title: Senior Account Manager

Telephone Number of authorized representative or licensed agent of insurance carrier: 516-349-1333

Please Note: Only insurance carriers and their licensed agents are authorized to issue Form C-105.2. Insurance brokers are NOT authorized to issue it.

Workers' Compensation Law

Section 57. Restriction on issue of permits and the entering into contracts unless compensation is secured.

1. The head of a state or municipal department, board, commission or office authorized or required by law to issue any permit for or in connection with any work involving the employment of employees in a hazardous employment defined by this chapter, and notwithstanding any general or special statute requiring or authorizing the issue of such permits, shall not issue such permit unless proof duly subscribed by an insurance carrier is produced in a form satisfactory to the chair, that compensation for all employees has been secured as provided by this chapter. Nothing herein, however, shall be construed as creating any liability on the part of such state or municipal department, board, commission or office to pay any compensation to any such employee if so employed.
2. The head of a state or municipal department, board, commission or office authorized or required by law to enter into any contract for or in connection with any work involving the employment of employees in a hazardous employment defined by this chapter, notwithstanding any general or special statute requiring or authorizing any such contract, shall not enter into any such contract unless proof duly subscribed by an insurance carrier is produced in a form satisfactory to the chair, that compensation for all employees has been secured as provided by this chapter.



CERTIFICATE OF INSURANCE COVERAGE
DISABILITY AND PAID FAMILY LEAVE BENEFITS LAW

PART 1. To be completed by Disability and Paid Family Leave Benefits Carrier or Licensed Insurance Agent of that Carrier

<p>1a. Legal Name & Address of Insured (use street address only) ADC CONSTRUCTION LLC. ATT: DOMINICK CIPOLLONE 58-08 48TH STREET MASPETH, NY 11378</p> <p>Work Location of Insured (Only required if coverage is specifically limited to certain locations in New York State, i.e., Wrap-Up Policy) 59-17 JUNCTION BLVD</p>	<p>1b. Business Telephone Number of Insured 7186280234</p> <p>1c. Federal Employer Identification Number of Insured or Social Security Number 11-3353007</p>
<p>2. Name and Address of Entity Requesting Proof of Coverage (Entity Being Listed as the Certificate Holder) NYC DEPARTMENT OF ENVIRONMENTAL PROTECTION 59-17 JUNCTION BLVD FLUSHING, NY 11373 11373</p>	<p>3a. Name of Insurance Carrier Standard Security Life Insurance Company of New York</p> <p>3b. Policy Number of Entity Listed in Box "1a" R90999-000</p> <p>3c. Policy effective period 1/1/2013 to 2/8/2021</p>

4. Policy provides the following benefits:

- A. Both disability and paid family leave benefits.
- B. Disability benefits only.
- C. Paid family leave benefits only.

5. Policy covers:

- A. All of the employer's employees eligible under the NYS Disability and Paid Family Leave Benefits Law.
- B. Only the following class or classes of employer's employees:

Under penalty of perjury, I certify that I am an authorized representative or licensed agent of the insurance carrier referenced above and that the named insured has NYS Disability and/or Paid Family Leave Benefits insurance coverage as described above.

Date Signed 2/10/2020 By *Beth A. Spampal*
(Signature of insurance carrier's authorized representative or NYS Licensed Insurance Agent of that insurance carrier)

Telephone Number (212) 355-4141 Name and Title SUPERVISOR-DBL/POLICY SERVICES

IMPORTANT: If Boxes 4A and 5A are checked, and this form is signed by the insurance carrier's authorized representative or NYS Licensed Insurance Agent of that carrier, this certificate is COMPLETE. Mail it directly to the certificate holder.

If Box 4B, 4C or 5B is checked, this certificate is NOT COMPLETE for purposes of Section 220, Subd. 8 of the NYS Disability and Paid Family Leave Benefits Law. It must be mailed for completion to the Workers' Compensation Board, Plans Acceptance Unit, PO Box 5200, Binghamton, NY 13902-5200.

PART 2. To be completed by the NYS Workers' Compensation Board (Only if Box 4C or 5B of Part 1 has been checked)

**State of New York
Workers' Compensation Board**

According to information maintained by the NYS Workers' Compensation Board, the above-named employer has complied with the NYS Disability and Paid Family Leave Benefits Law with respect to all of his/her employees.

Date Signed _____ By _____
(Signature of Authorized NYS Workers' Compensation Board Employee)

Telephone Number _____ Name and Title _____

Please Note: Only insurance carriers licensed to write NYS disability and paid family leave benefits insurance policies and NYS licensed insurance agents of those insurance carriers are authorized to issue Form DB-120.1. Insurance brokers are NOT authorized to issue this form.



Additional Instructions for Form DB-120.1

By signing this form, the insurance carrier identified in Box 3 on this form is certifying that it is insuring the business referenced in box "1a" for disability and/or paid family leave benefits under the New York State Disability and Paid Family Leave Benefits Law. The Insurance Carrier or its licensed agent will send this Certificate of Insurance to the entity listed as the certificate holder in Box 2.

The insurance carrier must notify the above certificate holder and the Workers' Compensation Board within 10 days IF a policy is cancelled due to nonpayment of premiums or within 30 days IF there are reasons other than nonpayment of premiums that cancel the policy or eliminate the insured from coverage indicated on this Certificate. (These notices may be sent by regular mail.) Otherwise, this Certificate is valid for one year after this form is approved by the insurance carrier or its licensed agent, or until the policy expiration date listed in Box 3c, whichever is earlier.

This certificate is issued as a matter of information only and confers no rights upon the certificate holder. This certificate does not amend, extend or alter the coverage afforded by the policy listed, nor does it confer any rights or responsibilities beyond those contained in the referenced policy.

This certificate may be used as evidence of a Disability and/or Paid Family Leave Benefits contract of insurance only while the underlying policy is in effect.

Please Note: Upon the cancellation of the disability and/or paid family leave benefits policy indicated on this form, if the business continues to be named on a permit, license or contract issued by a certificate holder, the business must provide that certificate holder with a new Certificate of NYS Disability and/or Paid Family Leave Benefits Coverage or other authorized proof that the business is complying with the mandatory coverage requirements of the New York State Disability and Paid Family Leave Benefits Law.

DISABILITY AND PAID FAMILY LEAVE BENEFITS LAW

§220. Subd. 8

(a) The head of a state or municipal department, board, commission or office authorized or required by law to issue any permit for or in connection with any work involving the employment of employees in employment as defined in this article, and notwithstanding any general or special statute requiring or authorizing the issue of such permits, shall not issue such permit unless proof duly subscribed by an insurance carrier is produced in a form satisfactory to the chair, that the payment of disability benefits and after January first, two thousand and twenty-one, the payment of family leave benefits for all employees has been secured as provided by this article. Nothing herein, however, shall be construed as creating any liability on the part of such state or municipal department, board, commission or office to pay any disability benefits to any such employee if so employed.

(b) The head of a state or municipal department, board, commission or office authorized or required by law to enter into any contract for or in connection with any work involving the employment of employees in employment as defined in this article and notwithstanding any general or special statute requiring or authorizing any such contract, shall not enter into any such contract unless proof duly subscribed by an insurance carrier is produced in a form satisfactory to the chair, that the payment of disability benefits and after January first, two thousand eighteen, the payment of family leave benefits for all employees has been secured as provided by this article.

CITY OF NEW YORK

CERTIFICATION BY INSURANCE BROKER OR AGENT

The undersigned insurance broker represents to the City of New York that the attached Certificate of Insurance is accurate in all material respects.

Vanguard Coverage
[Name of broker or agent (typewritten)]

101 Sunnyside Blvd Suite 100 Plainview, NY 11803
[Address of broker or agent (typewritten)]

Rburger @ vanguard Coverage. Com
[Email address of broker or agent (typewritten)]

516-349-1333
[Phone number/Fax number of broker or agent (typewritten)]

[Signature]
[Signature of authorized official, broker, or agent]

Robin Burger Senior Acct Manager
[Name and title of authorized official, broker, or agent (typewritten)]

State of NY
County of Nassau) ss.:

Sworn to before me this 2nd day of June, 2020

NOTARY PUBLIC FOR THE STATE OF NY

Lynn Ann Infanti
Notary Public, State of New York
No. 011N6004351
Qualified in Suffolk County
Commission Expires March 23, 2022

(NO TEXT ON THIS PAGE)

OFFICE OF THE COMPTROLLER, CITY OF NEW YORK
CONSTRUCTION WORKER PREVAILING WAGE SCHEDULE

LABOR LAW ARTICLE 8 - NYC PUBLIC WORKS

Workers, Laborers and Mechanics employed on a public work project must receive not less than the prevailing rate of wage and benefits for the classification of work performed by each upon such public work. Pursuant to Labor Law Article 8 the Comptroller of the City of New York has promulgated this schedule solely for Workers, Laborers and Mechanics engaged by private contractors on New York City public work projects. Prevailing rates are required to be annexed to and form part of the public work contract pursuant to § 220 (3).

This schedule is a compilation of separate determinations of the prevailing rate of wage and supplements made by the Comptroller for each trade classification listed herein pursuant to New York State Labor Law section § 220 (5). The source of the wage and supplement rates, whether a collective bargaining agreement, survey data or other, is listed at the end of each classification.

Agency Chief Contracting Officers should contact the Bureau of Labor Law's Classification Unit with any questions concerning trade classifications, prevailing rates or prevailing practices with respect to procurement on New York City public work contracts. Contractors are advised to review the Comptroller's Prevailing Wage Schedule before bidding on public work contracts. Contractors with questions concerning trade classifications, prevailing rates or prevailing practices with respect to public work contracts in the procurement stage must contact the contracting agency responsible for the procurement.

Any error as to compensation under the prevailing wage law or other information as to trade classification, made by the contracting agency in the contract documents or in any other communication, will not preclude a finding against the contractor of prevailing wage violation.

Any questions concerning trade classifications, prevailing rates or prevailing practices on New York City public work contracts that have already been awarded may be directed to the Bureau of Labor Law's Classification Unit by calling (212) 669-4443. All callers must have the agency name and contract registration number available when calling with questions on public work contracts. Please direct all other compliance issues to: Bureau of Labor Law, Attn: Wasyl Kinach, P.E., Office of the Comptroller, 1 Centre Street, Room 651, New York, N.Y. 10007; Fax (212) 669-4002.

The appropriate schedule of prevailing wages and benefits must be posted at all public work sites pursuant to Labor Law § 220 (3-a) (a).

This schedule is applicable to work performed during the effective period, unless otherwise noted. Changes to this schedule are published on our web site comptroller.nyc.gov/wages. Contractors must pay the wages and supplements in effect when the worker, laborer, mechanic performs the work. Preliminary schedules for future one-year periods appear in the City Record on or about June 1 each succeeding year. Final schedules appear on or about July 1 in the City Record and on our web site comptroller.nyc.gov/wages.

The Comptroller's Office has attempted to include all overtime, shift and night differential, Holiday, Saturday, Sunday or other premium time work. However, this schedule does not set forth every prevailing practice with respect to such rates with which employers must comply. All such practices are nevertheless part of the employer's prevailing wage obligation and contained in the collective bargaining agreements of the prevailing wage unions. These collective bargaining agreements are available for inspection by appointment. Requests for appointments may be made by calling (212) 669-4443, Monday through Friday between the hours of 9 a.m. and 5 p.m.

OFFICE OF THE COMPTROLLER, CITY OF NEW YORK
CONSTRUCTION WORKER PREVAILING WAGE SCHEDULE

Prevailing rates and ratios for apprentices are published in the Construction Apprentice Prevailing Wage Schedule. Pursuant to Labor Law § 220 (3-e), only apprentices who are individually registered in a bona fide program to which the employer contractor is a participant, registered with the New York State Department of Labor, may be paid at the apprentice rates. Apprentices who are not so registered must be paid as journey persons.

New York City public work projects awarded pursuant to a Project Labor Agreement ("PLA") in accordance with Labor Law section 222 may have different labor standards for shift, premium and overtime work. Please refer to the PLA's pre-negotiated labor agreements for wage and benefit rates applicable to work performed outside of the regular workday. More information is available at the Mayor's Office of Contract Services (MOCS) web page at:

<https://www1.nyc.gov/site/mocs/legal-forms/project-labor-agreements.page>

All the provisions of Labor Law Article 8 remain applicable to PLA work including, but not limited to, the enforcement of prevailing wage requirements by the Comptroller in accordance with the trade classifications in this schedule; however, we will enforce shift, premium, overtime and other non-standard rates as they appear in a project's pre-negotiated labor agreement.

In order to meet their obligation to provide prevailing supplemental benefits to each covered employee, employers must either:

- 1) Provide bona fide fringe benefits which cost the employer no less than the prevailing supplemental benefits rate; or
- 2) Supplement the employee's hourly wage by an amount no less than the prevailing supplemental benefits rate; or
- 3) Provide a combination of bona fide fringe benefits and wage supplements which cost the employer no less than the prevailing supplemental benefits rate in total.

Although prevailing wage laws do not require employers to provide bona fide fringe benefits (as opposed to wage supplements) to their employees, other laws may. For example, the Employee Retirement Income Security Act, 29 U.S.C. § 1001 et seq., the Patient Protection and Affordable Care Act, 42 U.S.C. § 18001 et seq., and the New York City Paid Sick Leave Law, N.Y.C. Admin. Code § 20-911 et seq., require certain employers to provide certain benefits to their employees. Labor agreements to which employers are a party may also require certain benefits. The Comptroller's Office does not enforce these laws or agreements.

Employers must provide prevailing supplemental benefits at the straight time rate for each hour worked unless otherwise noted in the classification.

Paid Holidays, Vacation and Sick Leave when listed must be paid or provided in addition to the prevailing hourly supplemental benefit rate.

For more information, please refer to the Comptroller's Prevailing Wage Law Regulations in Title 44 of the Rules of the City of New York, Chapter 2, available at comptroller.nyc.gov/wages.

Wasył Kinach, P.E.
Director of Classifications
Bureau of Labor Law

OFFICE OF THE COMPTROLLER, CITY OF NEW YORK
CONSTRUCTION WORKER PREVAILING WAGE SCHEDULE

TABLE OF CONTENTS

<u>CLASSIFICATION</u>	<u>PAGE</u>
ASBESTOS HANDLER	6
BLASTER	6
BOILERMAKER	7
BRICKLAYER	8
CARPENTER - BUILDING COMMERCIAL	9
CARPENTER - HEAVY CONSTRUCTION WORK	10
CARPENTER - HIGH RISE CONCRETE FORMS	11
CARPENTER - SIDEWALK SHED, SCAFFOLD AND HOIST	12
CARPENTER - WOOD WATER STORAGE TANK	12
CEMENT & CONCRETE WORKER	13
CEMENT MASON	14
CORE DRILLER	15
DERRICKPERSON AND RIGGER	17
DIVER	17
DOCKBUILDER - PILE DRIVER	18
DRIVER: TRUCK (TEAMSTER)	19
ELECTRICIAN	21
ELECTRICIAN - ALARM TECHNICIAN	24
ELECTRICIAN-STREET LIGHTING WORKER	25
ELEVATOR CONSTRUCTOR	26
ELEVATOR REPAIR & MAINTENANCE	27
ENGINEER	28
ENGINEER - CITY SURVEYOR AND CONSULTANT	33
ENGINEER - FIELD (BUILDING CONSTRUCTION)	34
ENGINEER - FIELD (HEAVY CONSTRUCTION)	35

**OFFICE OF THE COMPTROLLER, CITY OF NEW YORK
CONSTRUCTION WORKER PREVAILING WAGE SCHEDULE**

ENGINEER - FIELD (STEEL ERECTION)	36
ENGINEER - OPERATING	37
FLOOR COVERER	44
GLAZIER	45
GLAZIER - REPAIR & MAINTENANCE	46
HAZARDOUS MATERIAL HANDLER	47
HEAT AND FROST INSULATOR	48
HOUSE WRECKER	49
IRON WORKER - ORNAMENTAL	49
IRON WORKER - STRUCTURAL	50
LABORER	51
LANDSCAPING	52
MARBLE MECHANIC	54
MASON TENDER	55
MASON TENDER (INTERIOR DEMOLITION WORKER)	56
METALLIC LATHER	57
MILLWRIGHT	57
MOSAIC MECHANIC	58
PAINTER	59
PAINTER - LINE STRIPING (ROADWAY)	60
PAINTER - METAL POLISHER	61
PAINTER - SIGN	62
PAINTER - STRUCTURAL STEEL	63
PAPERHANGER	64
PAVER AND ROADBUILDER	65
PLASTERER	67
PLASTERER - TENDER	67
PLUMBER	68

OFFICE OF THE COMPTROLLER, CITY OF NEW YORK
CONSTRUCTION WORKER PREVAILING WAGE SCHEDULE

PLUMBER (MECHNICAL EQUIPMENT AND SERVICE).....	69
PLUMBER (RESIDENTIAL RATES FOR 1, 2 AND 3 FAMILY HOME CONSTRUCTION).....	70
PLUMBER: PUMP & TANK.....	71
POINTER, WATERPROOFER, CAULKER, SANDBLASTER, STEAMBLASTER.....	72
ROOFER.....	72
SHEET METAL WORKER.....	73
SHEET METAL WORKER - SPECIALTY.....	74
SHIPYARD WORKER.....	75
SIGN ERECTOR.....	77
STEAMFITTER.....	77
STEAMFITTER - REFRIGERATION AND AIR CONDITIONER.....	79
STONE MASON - SETTER.....	81
TAPER.....	82
TELECOMMUNICATION WORKER.....	83
TILE FINISHER.....	84
TILE LAYER - SETTER.....	85
TIMBERPERSON.....	85
TUNNEL WORKER.....	86
UTILITY LOCATOR.....	88
WELDER.....	90

**ASBESTOS HANDLER
SEE HAZARDOUS MATERIAL HANDLER**

BLASTER

Blaster

Effective Period: 7/1/2019 - 6/30/2020
Wage Rate per Hour: **\$55.86**
Supplemental Benefit Rate per Hour: **\$44.48**

Blaster- Hydraulic Trac Drill

Effective Period: 7/1/2019 - 6/30/2020
Wage Rate per Hour: **\$50.00**
Supplemental Benefit Rate per Hour: **\$44.48**

Blaster - Wagon: Air Trac: Quarry Bar: Drillrunners

Effective Period: 7/1/2019 - 6/30/2020
Wage Rate per Hour: **\$49.17**
Supplemental Benefit Rate per Hour: **\$44.48**

Blaster - Journeyperson

(Laborer, Chipper/Jackhammer including Walk Behind Self Propelled Hydraulic Asphalt and Concrete Breakers and Hydro (Water) Demolition, Powder Carrier, Hydraulic Chuck Tender, Chuck Tender and Nipper)

Effective Period: 7/1/2019 - 6/30/2020
Wage Rate per Hour: **\$42.65**
Supplemental Benefit Rate per Hour: **\$44.48**

Blaster - Magazine Keepers: (Watch Person)

Effective Period: 7/1/2019 - 6/30/2020
Wage Rate per Hour: **\$21.33**
Supplemental Benefit Rate per Hour: **\$44.48**

Overtime

Time and one half the regular rate after an 8 hour day.
Time and one half the regular rate for Saturday.
Double time the regular rate for Sunday.

OFFICE OF THE COMPTROLLER, CITY OF NEW YORK
CONSTRUCTION WORKER PREVAILING WAGE SCHEDULE

Overtime Holidays

Double time the regular rate for work on the following holiday(s).

New Year's Day
Memorial Day
Independence Day
Labor Day
Columbus Day
Thanksgiving Day
Christmas Day

Paid Holidays

Labor Day
Thanksgiving Day

Shift Rates

When two shifts are employed, single time rate shall be paid for each shift. When three shifts are found necessary, each shift shall work seven and one half hours (7 ½), but shall be paid for eight (8) hours of labor, and be permitted one half hour for lunch.

(Local #731)

BOILERMAKER

Boilermaker

Effective Period: 7/1/2019 - 6/30/2020

Wage Rate per Hour: **\$59.17**

Supplemental Benefit Rate per Hour: **\$44.59**

Supplemental Note: For time and one half overtime - **\$66.44** For double overtime - **\$88.28**

Overtime Description

For Repair and Maintenance work:

Time and one half the regular rate after an 8 hour day.

Time and one half the regular rate for Saturday.

Double time the regular rate for Sunday.

For New Construction work:

Double time the regular rate after an 8 hour day.

Double time the regular time rate for Saturday.

Double time the regular rate for Sunday.

Overtime Holidays

Double time the regular rate for work on the following holiday(s).

New Year's Day
President's Day
Memorial Day
Independence Day

OFFICE OF THE COMPTROLLER, CITY OF NEW YORK
CONSTRUCTION WORKER PREVAILING WAGE SCHEDULE

Columbus Day
Election Day
Veteran's Day
Thanksgiving Day
Christmas Day

Quadruple time the regular rate for work on the following holiday(s).
Labor Day

Paid Holidays

Good Friday
Day after Thanksgiving
Day before Christmas
Day before New Year's Day

Shift Rates

When shifts are required, the first shift shall work eight (8) hours at the regular straight-time hourly rate. The second shift shall work seven and one-half (7 ½) hours and receive eight hours at the regular straight time hourly rate plus twenty-five cents (\$0.25) per hour. The third shift shall work seven (7) hours and receive eight hours at the regular straight time hourly rate plus fifty cents (\$0.50) per hour. A thirty (30) minute lunch period shall not be considered as time worked. Work in excess of the above shall be paid overtime at the appropriate new construction work or repair work overtime wage and supplemental benefit hourly rate.

(Local #5)

BRICKLAYER

Bricklayer

Effective Period: 7/1/2019 - 6/30/2020
Wage Rate per Hour: **\$56.32**
Supplemental Benefit Rate per Hour: **\$33.11**

Overtime

Time and one half the regular rate after a 7 hour day.
Time and one half the regular rate for Saturday.
Double time the regular rate for Sunday.
Saturday may be used as a make-up day at straight time when a day is lost during that week to inclement weather.

Overtime Holidays

Double time the regular rate for work on the following holiday(s).
New Year's Day
President's Day
Memorial Day
Independence Day
Labor Day

OFFICE OF THE COMPTROLLER, CITY OF NEW YORK
CONSTRUCTION WORKER PREVAILING WAGE SCHEDULE

Thanksgiving Day
Christmas Day

Paid Holidays

None

Shift Rates

Overtime rates to be paid outside the regular scheduled work day.

(Bricklayer District Council)

CARPENTER - BUILDING COMMERCIAL

Building Commercial

Effective Period: 7/1/2019 - 6/30/2020

Wage Rate per Hour: \$52.50

Supplemental Benefit Rate per Hour: \$46.38

Overtime

Time and one half the regular rate after an 8 hour day.

Time and one half the regular rate for Saturday.

Double time the regular rate for Sunday.

Saturday may be used as a make-up day at straight time when a day is lost during that week to inclement weather.

Overtime Holidays

Double time the regular rate for work on the following holiday(s).

New Year's Day

Washington's Birthday

Memorial Day

Independence Day

Labor Day

Columbus Day

Presidential Election Day

Thanksgiving Day

Day after Thanksgiving

Christmas Day

Paid Holidays

None

Shift Rates

The employer may work two (2) shifts with the first shift at the straight time wage rate starting at the established time between 7 a.m. and 9 a.m. The second shift will receive one hour at the double time rate of pay for the last hour of the shift; eight (8) hours pay for seven (7) hours of work, nine (9) hours pay for eight (8) hours of work.

OFFICE OF THE COMPTROLLER, CITY OF NEW YORK
CONSTRUCTION WORKER PREVAILING WAGE SCHEDULE

When it is not possible to conduct alteration work during regular working hours in a building occupied by tenants, the rule for the second shift will apply.

(Carpenters District Council)

CARPENTER - HEAVY CONSTRUCTION WORK
(Construction of Engineering Structures and Building Foundations)

Heavy Construction Work

Effective Period: 7/1/2019 - 6/30/2020

Wage Rate per Hour: **\$54.68**

Supplemental Benefit Rate per Hour: **\$51.73**

Overtime

Time and one half the regular rate after an 8 hour day.

Time and one half the regular rate for Saturday.

Double time the regular rate for Sunday.

Saturday may be used as a make-up day at straight time when a day is lost during that week to inclement weather.

Overtime Holidays

Double time the regular rate for work on the following holiday(s).

New Year's Day

President's Day

Memorial Day

Independence Day

Labor Day

Columbus Day

Presidential Election Day

Thanksgiving Day

Christmas Day

Paid Holidays

None

Shift Rates

Off shift work commencing between 5:00 P.M. and 11:00 P.M. shall work eight and one half hours allowing for one half hour for lunch. The wage rate shall be 113% of the straight time hourly wage rate.

(Carpenters District Council)

OFFICE OF THE COMPTROLLER, CITY OF NEW YORK
CONSTRUCTION WORKER PREVAILING WAGE SCHEDULE

CARPENTER - HIGH RISE CONCRETE FORMS
(Excludes Engineering Structures and Building Foundations)

Carpenter High Rise A

Effective Period: 7/1/2019 - 6/30/2020
Wage Rate per Hour: \$50.78
Supplemental Benefit Rate per Hour: \$43.44

Carpenter High Rise B

Carpenter High Rise B worker is excluded from high risk operations such as erection decking, perimeter debris netting, leading edge work, self-climbing form systems, and the installation of cocoon systems unless directly supervised by a Carpenter High Rise A worker.

Effective Period: 7/1/2019 - 6/30/2020
Wage Rate per Hour: \$40.19
Supplemental Benefit Rate per Hour: \$16.75

Overtime

Time and one half the regular rate after an 8 hour day.
Time and one half the regular rate for Saturday.
Double time the regular rate for Sunday.
Saturday may be used as a make-up day at straight time when a day is lost during that week to inclement weather.

Overtime Holidays

Time and one half the regular rate for work on the following holiday(s).

New Year's Day
President's Day
Good Friday
Memorial Day
Independence Day
Labor Day
Columbus Day
Presidential Election Day
Thanksgiving Day
Christmas Day

Paid Holidays

None

Shift Rates

The second shift wage rate shall be 113% of the straight time hourly wage rate. There must be a first shift in order to work a second shift.

(Carpenters District Council)

OFFICE OF THE COMPTROLLER, CITY OF NEW YORK
CONSTRUCTION WORKER PREVAILING WAGE SCHEDULE

CARPENTER - SIDEWALK SHED, SCAFFOLD AND HOIST

Carpenter - Hod Hoist

(Assisted by Mason Tender)

Effective Period: 7/1/2019 - 6/30/2020

Wage Rate per Hour: \$50.50

Supplemental Benefit Rate per Hour: \$39.56

Overtime

Time and one half the regular rate after an 8 hour day.

Time and one half the regular rate for Saturday.

Double time the regular rate for Sunday.

Saturday may be used as a make-up day at straight time when a day is lost during that week to inclement weather.

Overtime Holidays

Double time the regular rate for work on the following holiday(s).

New Year's Day

President's Day

Memorial Day

Independence Day

Labor Day

Columbus Day

Presidential Election Day

Thanksgiving Day

Day after Thanksgiving

Christmas Day

Paid Holidays

None

Shift Rates

The second shift will receive one hour at the double time rate of pay for the last hour of the shift; eight hours pay for seven hours of work, nine hours pay for eight hours of work. There must be a first shift in order to work a second shift.

(Carpenters District Council)

CARPENTER - WOOD WATER STORAGE TANK

OFFICE OF THE COMPTROLLER, CITY OF NEW YORK
CONSTRUCTION WORKER PREVAILING WAGE SCHEDULE

Tank Mechanic

Effective Period: 7/1/2019 - 6/30/2020
Wage Rate per Hour: **\$34.14**
Supplemental Benefit Rate per Hour: **\$19.00**

Tank Helper

Effective Period: 7/1/2019 - 6/30/2020
Wage Rate per Hour: **\$27.30**
Supplemental Benefit Rate per Hour: **\$19.00**

Overtime

Time and one half the regular rate after an 8 hour day.
Time and one half the regular rate for Saturday.
Double time the regular rate for Sunday.
Time and one half the regular rate for work on a holiday plus the day's pay.

Paid Holidays

New Year's Day
President's Day
Good Friday
Memorial Day
Independence Day
Labor Day
Columbus Day
Thanksgiving Day
Day after Thanksgiving
1/2 day on Christmas Eve if work is performed in the A.M.
1/2 day on New Year's Eve if work is performed in the A.M.

Vacation

Employed for one (1) year.....one (1) week vacation (40 hours)
Employed for three (3) years.....two (2) weeks vacation (80 hours)
Employed for more than twenty (20) years.....three (3) weeks vacation (120 hours)

SICK LEAVE:

Two (2) sick days after being employed for twenty (20) years.

(Carpenters District Council)

CEMENT & CONCRETE WORKER

Cement & Concrete Worker

Effective Period: 7/1/2019 - 6/30/2020
Wage Rate per Hour: **\$43.53**

OFFICE OF THE COMPTROLLER, CITY OF NEW YORK
CONSTRUCTION WORKER PREVAILING WAGE SCHEDULE

Supplemental Benefit Rate per Hour: \$28.95
Supplemental Note: \$32.45 on Saturdays; \$35.95 on Sundays & Holidays

Cement & Concrete Worker - (Hired after 2/6/2016)

Effective Period: 7/1/2019 - 6/30/2020
Wage Rate per Hour: \$33.05
Supplemental Benefit Rate per Hour: \$20.95
Supplemental Note: \$22.45 on Saturdays; \$23.95 on Sundays & Holidays

Overtime Description

Time and one half the regular rate after 7 hour day (time and one half the regular rate after an 8 hour day when working with Dockbuilders on pile cap forms and for work below street level to the top of the foundation wall, not to exceed 2 feet or 3 feet above the sidewalk-brick shelf, when working on the foundation and structure.)

Overtime

Time and one half the regular rate for Saturday.
Double time the regular rate for Sunday.

Overtime Holidays

Double time the regular rate for work on the following holiday(s).

New Year's Day
President's Day
Good Friday
Memorial Day
Independence Day
Labor Day
Columbus Day
Presidential Election Day
Thanksgiving Day
Christmas Day

Paid Holidays

1/2 day before Christmas Day
1/2 day before New Year's Day

Shift Rates

On shift work extending over a twenty-four hour period, all shifts are paid at straight time.

(Cement Concrete Workers District Council)

CEMENT MASON

Cement Mason

Effective Period: 7/1/2019 - 6/30/2020

OFFICE OF THE COMPTROLLER, CITY OF NEW YORK
CONSTRUCTION WORKER PREVAILING WAGE SCHEDULE

Wage Rate per Hour: **\$44.97**

Supplemental Benefit Rate per Hour: **\$40.56**

Supplemental Note: Supplemental benefit time and one half rate: **\$71.19**; Double time rate: double the base supplemental benefit rate.

Overtime Description

Time and one-half the regular rate after an 8 hour day, double time the regular rate after 10 hours. Time and one-half the regular rate on Saturday, double time the regular rate after 10 hours. Double time the regular rate on Sunday.

Overtime Holidays

Double time the regular rate for work on the following holiday(s).

New Year's Day

President's Day

Good Friday

Memorial Day

Independence Day

Labor Day

Columbus Day

Presidential Election Day

Thanksgiving Day

Christmas Day

Paid Holidays

Any worker who reports to work on Christmas Eve or New Year's Eve pursuant to his employer's instruction shall be entitled to three (3) hours afternoon pay without working.

Shift Rates

For an off shift day, (work at times other than the regular 7:00 A.M. to 3:30 P.M. work day) a cement mason shall be paid at the regular hourly rate plus a 25% per hour differential. Four Days a week at Ten (10)hour day.

(Local #780) (BCA)

CORE DRILLER

Core Driller

Effective Period: 7/1/2019 - 6/30/2020

Wage Rate per Hour: **\$40.44**

Supplemental Benefit Rate per Hour: **\$26.70**

Core Driller Helper

Effective Period: 7/1/2019 - 6/30/2020

Wage Rate per Hour: **\$32.12**

Supplemental Benefit Rate per Hour: **\$26.70**

OFFICE OF THE COMPTROLLER, CITY OF NEW YORK
CONSTRUCTION WORKER PREVAILING WAGE SCHEDULE

Core Driller Helper(Third year in the industry)

Effective Period: 7/1/2019 - 6/30/2020
Wage Rate per Hour: \$28.91
Supplemental Benefit Rate per Hour: \$26.70

Core Driller Helper (Second year in the industry)

Effective Period: 7/1/2019 - 6/30/2020
Wage Rate per Hour: \$25.70
Supplemental Benefit Rate per Hour: \$26.70

Core Driller Helper (First year in the industry)

Effective Period: 7/1/2019 - 6/30/2020
Wage Rate per Hour: \$22.48
Supplemental Benefit Rate per Hour: \$26.70

Overtime Description

Time and one half the regular rate for work on a holiday plus Holiday pay when worked.

Overtime

Time and one half the regular rate after an 8 hour day.
Time and one half the regular rate for Saturday.
Double time the regular rate for Sunday.
Time and one half the regular rate for work on the following holiday(s).

Paid Holidays

New Year's Day
Memorial Day
Independence Day
Labor Day
Thanksgiving Day
Christmas Day

Shift Rates

The shift day shall be the continuous eight and one-half (8½) hours from 6:00 A.M. to 2:30 P.M. and from 2:30 P.M. to 11:00 P.M., including one-half (½) hour of employees regular rate of pay for lunch. When two (2) or more shifts are employed, single time shall be paid for each shift, but those employees employed on a shift other than from 8:00 A.M. to 5:00 P.M. shall, in addition, receive seventy-five cents (\$0.75) per hour differential for each hour worked. When three (3) shifts are needed, each shift shall work seven and one-half (7 ½) hours paid for eight (8) hours of labor and be permitted one-half (½) hour for mealtime.

(Carpenters District Council)

OFFICE OF THE COMPTROLLER, CITY OF NEW YORK
CONSTRUCTION WORKER PREVAILING WAGE SCHEDULE

DERRICKPERSON AND RIGGER

Derrick Person & Rigger

Effective Period: 7/1/2019 - 6/30/2020

Wage Rate per Hour: **\$50.91**

Supplemental Benefit Rate per Hour: **\$54.11**

Supplemental Note: The above supplemental rate applies for work performed in Manhattan, Bronx, Brooklyn and Queens. \$55.53 - For work performed in Staten Island.

Derrick Person & Rigger - Site Work

Assists the Stone Mason-Setter in the setting of stone and paving stone.

Effective Period: 7/1/2019 - 6/30/2020

Wage Rate per Hour: **\$42.59**

Supplemental Benefit Rate per Hour: **\$42.37**

Overtime Description

The first two hours of overtime on weekdays and the first seven hours of work on Saturdays are paid at time and one half for wages and supplemental benefits. All additional overtimes is paid at double time for wages and supplemental benefits. Deduct \$1.42 from the Staten Island hourly benefits rate before computing overtime.

Overtime

Double time the regular rate for Sunday.

Overtime Holidays

Double time the regular rate for work on the following holiday(s).

New Year's Day
Washington's Birthday
Good Friday
Memorial Day
Independence Day
Labor Day
Thanksgiving Day
Christmas Day

Paid Holidays

1/2 day on Christmas Eve if work is performed in the A.M.

(Local #197)

DIVER

Diver (Marine)

OFFICE OF THE COMPTROLLER, CITY OF NEW YORK
CONSTRUCTION WORKER PREVAILING WAGE SCHEDULE

Effective Period: 7/1/2019 - 6/30/2020
Wage Rate per Hour: \$69.22
Supplemental Benefit Rate per Hour: \$51.73

Diver Tender (Marine)

Effective Period: 7/1/2019 - 6/30/2020
Wage Rate per Hour: \$49.14
Supplemental Benefit Rate per Hour: \$51.73

Overtime

Time and one half the regular rate after an 8 hour day.
Time and one half the regular rate for Saturday.
Double time the regular rate for Sunday.
Saturday may be used as a make-up day at straight time when a day is lost during that week to inclement weather.

Overtime Holidays

Double time the regular rate for work on the following holiday(s).

- New Year's Day
- President's Day
- Memorial Day
- Independence Day
- Labor Day
- Columbus Day
- Presidential Election Day
- Thanksgiving Day
- Christmas Day

Paid Holidays

None

Shift Rates

When three shifts are utilized each shift shall work seven and one half-hours (7 1/2 hours) and paid for 8 hours, allowing for one half hour for lunch.

(Carpenters District Council)

DOCKBUILDER - PILE DRIVER

Dockbuilder - Pile Driver

Effective Period: 7/1/2019 - 6/30/2020
Wage Rate per Hour: \$54.63
Supplemental Benefit Rate per Hour: \$51.73

OFFICE OF THE COMPTROLLER, CITY OF NEW YORK
CONSTRUCTION WORKER PREVAILING WAGE SCHEDULE

Overtime

Time and one half the regular rate after an 8 hour day.

Time and one half the regular rate for Saturday.

Double time the regular rate for Sunday.

Saturday may be used as a make-up day at straight time when a day is lost during that week to inclement weather.

Overtime Holidays

Double time the regular rate for work on the following holiday(s).

New Year's Day

President's Day

Memorial Day

Independence Day

Labor Day

Columbus Day

Presidential Election Day

Thanksgiving Day

Christmas Day

Paid Holidays

None

Shift Rates

Off shift work commencing between 5:00 P.M. and 11:00 P.M. shall work eight and one half hours allowing for one half hour for lunch. The wage rate shall be 113% of the straight time hourly wage rate.

(Carpenters District Council)

DRIVER: TRUCK (TEAMSTER)

Driver - Dump Truck

Effective Period: 7/1/2019 - 6/30/2020

Wage Rate per Hour: \$41.18

Supplemental Benefit Rate per Hour: \$49.65

Supplemental Note: Over 40 hours worked: at time and one half rate - \$22.08; at double time rate - \$29.44

Driver - Tractor Trailer

Effective Period: 7/1/2019 - 6/30/2020

Wage Rate per Hour: \$43.84

Supplemental Benefit Rate per Hour: \$49.03

Supplemental Note: Over 40 hours worked: at time and one half rate - \$19.80; at double time rate - \$26.40

Driver - Euclid & Turnapull Operator

OFFICE OF THE COMPTROLLER, CITY OF NEW YORK
CONSTRUCTION WORKER PREVAILING WAGE SCHEDULE

Effective Period: 7/1/2019 - 6/30/2020

Wage Rate per Hour: \$44.40

Supplemental Benefit Rate per Hour: \$49.03

Supplemental Note: Over 40 hours worked: at time and one half rate - \$19.80; at double time rate - \$26.40

Overtime Description

For Paid Holidays: Holiday pay for all holidays shall be prorated based two hours per day for each day worked in the holiday week, not to exceed 8 hours of holiday pay. For Thanksgiving week, the prorated share shall be 5 1/3 hours of holiday pay for each day worked in Thanksgiving week.

Overtime

Time and one half the regular rate after an 8 hour day.
Time and one half the regular rate for Saturday.
Double time the regular rate for Sunday.

Overtime Holidays

Double time the regular rate for work on the following holiday(s).

New Year's Day
President's Day
Memorial Day
Independence Day
Labor Day
Columbus Day
Veteran's Day
Thanksgiving Day
Day after Thanksgiving
Christmas Day

Paid Holidays

New Year's Day
President's Day
Memorial Day
Independence Day
Labor Day
Columbus Day
Veteran's Day
Thanksgiving Day
Day after Thanksgiving
Christmas Day

Shift Rates

Off single shift work commencing between 6:00 P.M. and 5:00 A.M. shall work eight and one half (8 1/2) hours allowing for one half hour for lunch and be paid 117.3% of the straight time hourly wage rate.

Driver Redi-Mix (Sand & Gravel)

Effective Period: 7/1/2019 - 6/30/2020

Wage Rate per Hour: \$39.00

OFFICE OF THE COMPTROLLER, CITY OF NEW YORK
CONSTRUCTION WORKER PREVAILING WAGE SCHEDULE

Supplemental Benefit Rate per Hour: \$45.52

Supplemental Note: Over 40 hours worked: time and one half rate \$16.78; double time rate \$22.37.

Overtime Description

For Paid Holidays: Employees working two (2) days in the calendar week in which the holiday falls are to paid for these holidays, provided they shape each remaining workday during that calendar week.

Overtime

Time and one half the regular rate after an 8 hour day.

Time and one half the regular rate for Saturday.

Double time the regular rate for Sunday.

Overtime Holidays

Double time the regular rate for work on the following holiday(s).

President's Day

Columbus Day

Veteran's Day

Triple time the regular rate for work on the following holiday(s).

New Year's Day

Memorial Day

Independence Day

Labor Day

Thanksgiving Day

Christmas Day

Paid Holidays

New Year's Day

President's Day

Memorial Day

Independence Day

Labor Day

Columbus Day

Election Day

Thanksgiving Day

Christmas Day

(Local #282)

ELECTRICIAN

(Including installation of low voltage cabling carrying data, video and/or voice on building construction/alteration/renovation projects.)

Electrician "A" (Regular Day / Day Shift)

Effective Period: 7/1/2019 - 6/30/2020

OFFICE OF THE COMPTROLLER, CITY OF NEW YORK
CONSTRUCTION WORKER PREVAILING WAGE SCHEDULE

Wage Rate per Hour: \$56.00
Supplemental Benefit Rate per Hour: \$56.54

Electrician "A" (Regular Day Overtime after 7 hrs / Day Shift Overtime after 8 hrs)

Effective Period: 7/1/2019 - 6/30/2020
Wage Rate per Hour: \$84.00
Supplemental Benefit Rate per Hour: \$60.07

Electrician "A" (Swing Shift)

Effective Period: 7/1/2019 - 6/30/2020
Wage Rate per Hour: \$65.71
Supplemental Benefit Rate per Hour: \$64.36

Electrician "A" (Swing Shift Overtime After 7.5 hours)

Effective Period: 7/1/2019 - 6/30/2020
Wage Rate per Hour: \$98.57
Supplemental Benefit Rate per Hour: \$68.51

Electrician "A" (Graveyard Shift)

Effective Period: 7/1/2019 - 6/30/2020
Wage Rate per Hour: \$73.60
Supplemental Benefit Rate per Hour: \$70.94

Electrician "A" (Graveyard Shift Overtime After 7 hours)

Effective Period: 7/1/2019 - 6/30/2020
Wage Rate per Hour: \$110.40
Supplemental Benefit Rate per Hour: \$75.59

Overtime

Time and one half the regular rate after a 7 hour day.
Time and one half the regular rate for Saturday.
Time and one half the regular rate for Sunday.

Overtime Holidays

Time and one half the regular rate for work on a holiday.
New Year's Day
Martin Luther King Jr. Day
President's Day
Memorial Day
Independence Day
Labor Day
Columbus Day
Veteran's Day
Thanksgiving Day
Day after Thanksgiving

OFFICE OF THE COMPTROLLER, CITY OF NEW YORK
CONSTRUCTION WORKER PREVAILING WAGE SCHEDULE

Christmas Day

Paid Holidays

None

Shift Rates

When so elected by the Employer, one or more shifts of at least five days duration may be scheduled as follows:
Day Shift: 8:00 am to 4:30 pm, Swing Shift 4:30 pm to 12:30 am, Graveyard Shift: 12:30 am to 8:00 am.

For multiple shifts of temporary light and/or power, the temporary light and/or power employee shall be paid for 8 hours at the straight time rate. For three or less workers performing 8 hours temporary light and/or power the supplemental benefit rate is \$24.92.

Electrician "M" (First 8 hours)

"M" rated work shall be defined as jobbing: electrical work of limited duration and scope, also consisting of repairs and/or replacement of electrical and tele-data equipment. Includes all work necessary to retrofit, service, maintain and repair all kinds of lighting fixtures and local lighting controls and washing and cleaning of foregoing fixtures.

Effective Period: 7/1/2019 - 6/30/2020

Wage Rate per Hour: **\$29.00**

Supplemental Benefit Rate per Hour: **\$23.43**

First and Second Year "M" Wage Rate Per Hour: **\$24.50**

First and Second Year "M" Supplemental Rate: **\$21.07**

Electrician "M" (Overtime After First 8 hours)

"M" rated work shall be defined as jobbing: electrical work of limited duration and scope, also consisting of repairs and/or replacement of electrical and tele-data equipment. Includes all work necessary to retrofit, service, maintain and repair all kinds of lighting fixtures and local lighting controls and washing and cleaning of foregoing fixtures.

Effective Period: 7/1/2019 - 6/30/2020

Wage Rate per Hour: **\$43.50**

Supplemental Benefit Rate per Hour: **\$25.26**

First and Second Year "M" Wage Rate Per Hour: **\$36.75**

First and Second Year "M" Supplemental Rate: **\$22.62**

Overtime

Time and one half the regular rate after an 8 hour day.

Time and one half the regular rate for Saturday.

Time and one half the regular rate for Sunday.

Overtime Holidays

Time and one half the regular rate for work on the following holiday(s).

New Year's Day

Martin Luther King Jr. Day

OFFICE OF THE COMPTROLLER, CITY OF NEW YORK
CONSTRUCTION WORKER PREVAILING WAGE SCHEDULE

President's Day
Memorial Day
Independence Day
Labor Day
Columbus Day
Veteran's Day
Thanksgiving Day
Day after Thanksgiving
Christmas Day

Paid Holidays

None

(Local #3)

ELECTRICIAN - ALARM TECHNICIAN

(Scope of Work - Inspect, test, repair, and replace defective, malfunctioning, or broken devices, components and controls of Fire, Burglar and Security Systems)

Alarm Technician

Effective Period: 7/1/2019 - 3/9/2020

Wage Rate per Hour: **\$33.40**

Supplemental Benefit Rate per Hour: **\$17.68**

Supplemental Note: \$16.06 only after 8 hours worked in a day

Effective Period: 3/10/2020 - 6/30/2020

Wage Rate per Hour: **\$33.90**

Supplemental Benefit Rate per Hour: **\$18.43**

Supplemental Note: \$16.80 only after 8 hours worked in a day

Overtime Description

Time and one half the regular rate for work on the following holidays: Columbus Day, Veterans Day, Day after Thanksgiving.

Double time the regular rate for work on the following holidays: New Year's day, Martin Luther King Jr. Day, President's Day, Memorial Day, Independence Day, Labor Day, Thanksgiving Day, Christmas Day.

Overtime

Time and one half the regular rate after an 8 hour day.

Time and one half the regular rate for Saturday.

Double time the regular rate for Sunday.

Paid Holidays

New Year's Day

OFFICE OF THE COMPTROLLER, CITY OF NEW YORK
CONSTRUCTION WORKER PREVAILING WAGE SCHEDULE

Martin Luther King Jr. Day
President's Day
Memorial Day
Independence Day
Labor Day
Columbus Day
Veteran's Day
Thanksgiving Day
Day after Thanksgiving
Christmas Day

Shift Rates

Night Differential is based upon a ten percent (10%) differential between the hours of 4:00 P.M. and 12:30 A.M. and a fifteen percent (15%) differential for the hours 12:00 A.M. to 8:00 A.M.

Vacation

At least 1 year of employment.....ten (10) days
5 years or more of employment.....fifteen (15) days
10 years of employment.....twenty (20) days
Plus one Personal Day per year

Sick Days:

One day per Year. Up to 4 vacation days may be used as sick days.

(Local #3)

ELECTRICIAN-STREET LIGHTING WORKER

Electrician - Electro Pole Electrician

Effective Period: 7/1/2019 - 6/30/2020
Wage Rate per Hour: \$56.00
Supplemental Benefit Rate per Hour: \$58.44

Electrician - Electro Pole Foundation Installer

Effective Period: 7/1/2019 - 6/30/2020
Wage Rate per Hour: \$42.66
Supplemental Benefit Rate per Hour: \$43.52

Electrician - Electro Pole Maintainer

Effective Period: 7/1/2019 - 6/30/2020
Wage Rate per Hour: \$36.61
Supplemental Benefit Rate per Hour: \$39.16

Overtime Description

OFFICE OF THE COMPTROLLER, CITY OF NEW YORK
CONSTRUCTION WORKER PREVAILING WAGE SCHEDULE

Electrician - Electro Pole Electrician: Time and one half the regular rate after a 7 hour day and after 5 consecutive days worked per week.

Electrician - Electro Pole Foundation Installer: Time and one half the regular rate after 8 hours within a 24 hour period and Saturday and Sunday.

Electrician - Electro Pole Maintainer: Time and one half the regular rate after a 7 hour day and after 5 consecutive days worked per week. Saturdays and Sundays may be used as a make-up day at straight time when a day is lost during the week to inclement weather.

Overtime Holidays

Time and one half the regular rate for work on the following holiday(s).

New Year's Day
Martin Luther King Jr. Day
President's Day
Memorial Day
Independence Day
Labor Day
Columbus Day
Veteran's Day
Thanksgiving Day
Day after Thanksgiving
Christmas Day

Paid Holidays

None

(Local #3)

ELEVATOR CONSTRUCTOR

Elevator Constructor

Effective Period: 7/1/2019 - 3/16/2020

Wage Rate per Hour: \$66.95

Supplemental Benefit Rate per Hour: \$36.65

Effective Period: 3/17/2020 - 6/30/2020

Wage Rate per Hour: \$69.56

Supplemental Benefit Rate per Hour: \$37.47

Overtime Description

For New Construction: work performed after 7 or 8 hour day, Saturday, Sunday or between 4:30pm and 7:00am shall be paid at double time rate.

Existing buildings: work performed after an 8 hour day, Saturday, Sunday or between 5:30pm and 7:00 am shall be paid time and one half.

Overtime

OFFICE OF THE COMPTROLLER, CITY OF NEW YORK
CONSTRUCTION WORKER PREVAILING WAGE SCHEDULE

Double time the regular rate for work on the following holiday(s).

Paid Holidays

New Year's Day
President's Day
Good Friday
Memorial Day
Independence Day
Labor Day
Columbus Day
Veteran's Day
Thanksgiving Day
Day after Thanksgiving
Christmas Day

Vacation

Employer contributes 8% of regular basic hourly rate as vacation pay for employees with more than 15 years of service, and 6% for employees with 5 to 15 years of service, and 4% for employees with less than 5 years of service.

(Local #1)

ELEVATOR REPAIR & MAINTENANCE

Elevator Service/Modernization Mechanic

Effective Period: 7/1/2019 - 3/16/2020

Wage Rate per Hour: **\$52.44**

Supplemental Benefit Rate per Hour: **\$36.55**

Effective Period: 3/17/2020 - 6/30/2020

Wage Rate per Hour: **\$54.56**

Supplemental Benefit Rate per Hour: **\$37.37**

Overtime Description

For Scheduled Service Work: Double time - work scheduled in advance by two or more workers performed on Sundays, Holidays, and between midnight and 7:00am.

Overtime

Time and one half the regular rate after an 8 hour day.

Time and one half the regular rate for Saturday.

Time and one half the regular rate for Sunday.

Time and one half the regular rate for work on a holiday plus the day's pay.

Paid Holidays

New Year's Day
President's Day

OFFICE OF THE COMPTROLLER, CITY OF NEW YORK
CONSTRUCTION WORKER PREVAILING WAGE SCHEDULE

Good Friday
Memorial Day
Independence Day
Labor Day
Columbus Day
Veteran's Day
Thanksgiving Day
Day after Thanksgiving
Christmas Day

Shift Rates

Afternoon shift - regularly hourly rate plus a (15%) fifteen percent differential. Graveyard shift - time and one half the regular rate.

Vacation

Employer contributes 8% of regular basic hourly rate as vacation pay for employees with more than 15 years of service, and 6% for employees with 5 to 15 years of service, and 4% for employees with less than 5 years of service.

(Local #1)

ENGINEER

Engineer - Heavy Construction Operating Engineer I

Cherry pickers 20 tons and over and Loaders (rubber tired and/or tractor type with a manufacturer's minimum rated capacity of six cubic yards and over).

Effective Period: 7/1/2019 - 6/30/2020

Wage Rate per Hour: \$70.71

Supplemental Benefit Rate per Hour: \$39.74

Supplemental Note: \$72.08 on overtime

Shift Wage Rate: \$113.14

Engineer - Heavy Construction Operating Engineer II

Backhoes, Basin Machines, Groover, Mechanical Sweepers, Bobcat, Boom Truck, Barrier Transport (Barrier Mover) & machines of similar nature. Operation of Churn Drills and machines of a similar nature, Stetco Silent Hoist and machines of similar nature, Vac-Alls, Meyers Machines, John Beam and machines of a similar nature, Ross Carriers and Travel Lifts and machines of a similar nature, Bulldozers, Scrapers and Turn-a-Pulls: Tugger Hoists (Used exclusively for handling excavated material); Tractors with attachments, Hyster and Roustabout Cranes, Cherry pickers. Austin Western, Grove and machines of a similar nature, Scoopmobiles, Monorails, Conveyors, Trenchers: Loaders-Rubber Tired and Tractor: Barber Greene and Eimco Loaders and Eimco Backhoes; Mighty Midget and similar breakers and Tampers, Curb and Gutter Pavers and Motor Patrol, Motor Graders and all machines of a similar nature. Locomotives 10 Tons or under. Mini-Max, Break-Tech and machines of a similar nature; Milling machines, robotic and demolition machines and machines of a similar nature, shot blaster, skid steer machines and machines of a similar nature including bobcat, pile rig rubber-tired excavator (37,000 lbs. and under), 2 man auger.

OFFICE OF THE COMPTROLLER, CITY OF NEW YORK
CONSTRUCTION WORKER PREVAILING WAGE SCHEDULE

Effective Period: 7/1/2019 - 6/30/2020
Wage Rate per Hour: \$68.58
Supplemental Benefit Rate per Hour: \$39.74
Supplemental Note: \$72.08 on overtime
Shift Wage Rate: \$109.73

Engineer - Heavy Construction Operating Engineer III

Minor Equipment such as Tractors, Post Hole Diggers, Ditch Witch (Walk Behind), Road Finishing Machines, Rollers five tons and under, Tugger Hoists, Dual Purpose Trucks, Fork Lifts, and Dempsey Dumpers, Fireperson.

Effective Period: 7/1/2019 - 6/30/2020
Wage Rate per Hour: \$65.00
Supplemental Benefit Rate per Hour: \$39.74
Supplemental Note: \$72.08 on overtime
Shift Wage Rate: \$104.00

Engineer - Heavy Construction Maintenance Engineer I

Installing, Repairing, Maintaining, Dismantling and Manning of all equipment including Steel Cutting, Bending and Heat Sealing Machines, Mechanical Heaters, Grout Pumps, Bentonite Pumps & Plants, Screening Machines, Fusion Coupling Machines, Tunnel Boring Machines Moles and Machines of a similar nature, Power Packs, Mechanical Hydraulic Jacks; all drill rigs including but not limited to Churn, Rotary Caisson, Raised Bore & Drills of a similar nature; Personnel, Inspection & Safety Boats or any boats used to perform functions of same, Mine Hoists, Whirlies, all Climbing Cranes, all Tower Cranes, including but not limited to Truck Mounted and Crawler Type and machines of similar nature; Maintaining Hydraulic Drills and machines of a similar nature; Well Point System-Installation and dismantling; Burning, Welding, all Pumps regardless of size and/or motor power, except River Cofferdam Pumps and Wells Point Pumps; Motorized Buggies (three or more); equipment used in the cleaning and televising of sewers, but not limited to jet-rodder/vacuum truck, vacall/vactor, closed circuit television inspection equipment; high powered water pumps, jet pumps; screed machines and concrete finishing machines of a similar nature; vermeers.

Effective Period: 7/1/2019 - 6/30/2020
Wage Rate per Hour: \$68.25
Supplemental Benefit Rate per Hour: \$39.74
Supplemental Note: \$72.08 on overtime
Shift Wage Rate: \$109.20

Engineer - Heavy Construction Maintenance Engineer II

On Base Mounted Tower Cranes

Effective Period: 7/1/2019 - 6/30/2020
Wage Rate per Hour: \$90.00
Supplemental Benefit Rate per Hour: \$39.74
Supplemental Note: \$72.08 on overtime
Shift Wage Rate: \$144.00

Engineer - Heavy Construction Maintenance Engineer III

OFFICE OF THE COMPTROLLER, CITY OF NEW YORK
CONSTRUCTION WORKER PREVAILING WAGE SCHEDULE

On Generators, Light Towers

Effective Period: 7/1/2019 - 6/30/2020
Wage Rate per Hour: \$44.64
Supplemental Benefit Rate per Hour: \$39.74
Supplemental Note: \$72.08 on overtime
Shift Wage Rate: \$71.42

Engineer - Heavy Construction Maintenance Engineer IV

On Pumps and Mixers including mud sucking

Effective Period: 7/1/2019 - 6/30/2020
Wage Rate per Hour: \$45.83
Supplemental Benefit Rate per Hour: \$39.74
Supplemental Note: \$72.08 on overtime
Shift Wage Rate: \$73.33

Engineer - Steel Erection Maintenance Engineers

Derrick, Travelers, Tower, Crawler Tower and Climbing Cranes

Effective Period: 7/1/2019 - 6/30/2020
Wage Rate per Hour: \$65.31
Supplemental Benefit Rate per Hour: \$39.74
Supplemental Note: \$72.08 on overtime
Shift Wage Rate: \$104.50

Engineer - Steel Erection Oiler I

On a Truck Crane

Effective Period: 7/1/2019 - 6/30/2020
Wage Rate per Hour: \$61.05
Supplemental Benefit Rate per Hour: \$39.74
Supplemental Note: \$72.08 on overtime
Shift Wage Rate: \$97.68

Engineer - Steel Erection Oiler II

On a Crawler Crane

Effective Period: 7/1/2019 - 6/30/2020
Wage Rate per Hour: \$46.18
Supplemental Benefit Rate per Hour: \$39.74
Supplemental Note: \$72.08 on overtime
Shift Wage Rate: \$73.89

Overtime Description

OFFICE OF THE COMPTROLLER, CITY OF NEW YORK
CONSTRUCTION WORKER PREVAILING WAGE SCHEDULE

On jobs of more than one shift, if the next shift employee fails to report for work through any cause over which the employer has no control, the employee on duty who works the next shift continues to work at the single time rate.

Overtime

Double time the regular rate after an 8 hour day.

Double time the regular time rate for Saturday.

Double time the regular rate for Sunday.

Double time the regular rate for work on the following holiday(s).

Paid Holidays

New Year's Day

Lincoln's Birthday

President's Day

Memorial Day

Independence Day

Labor Day

Columbus Day

Veteran's Day

Thanksgiving Day

Day after Thanksgiving

Christmas Day

Employees must work at least one day in the payroll week in which the holiday occurs to receive the paid holiday

Engineer - Building Work Maintenance Engineers I

Installing, repairing, maintaining, dismantling (of all equipment including: Steel Cutting and Bending Machines, Mechanical Heaters, Mine Hoists, Climbing Cranes, Tower Cranes, Linden Peine, Lorain, Liebherr, Mannes, or machines of a similar nature, Well Point Systems, Deep Well Pumps, Concrete Mixers with loading Device, Concrete Plants, Motor Generators when used for temporary power and lights), skid steer machines of a similar nature including bobcat.

Effective Period: 7/1/2019 - 6/30/2020

Wage Rate per Hour: \$62.45

Supplemental Benefit Rate per Hour: \$39.74

Supplemental Note: \$72.08 on overtime

Engineer - Building Work Maintenance Engineers II

On Pumps, Generators, Mixers and Heaters

Effective Period: 7/1/2019 - 6/30/2020

Wage Rate per Hour: \$48.26

Supplemental Benefit Rate per Hour: \$39.74

Supplemental Note: \$72.08 on overtime

Engineer - Building Work Oilers I

OFFICE OF THE COMPTROLLER, CITY OF NEW YORK
CONSTRUCTION WORKER PREVAILING WAGE SCHEDULE

All gasoline, electric, diesel or air operated Gradealls: Concrete Pumps, Overhead Cranes in Power Houses:
Their duties shall be to assist the Engineer in oiling, greasing and repairing of all machines; Driving Truck
Cranes: Driving and Operating Fuel and Grease Trucks, Cherrypickers (hydraulic cranes) over 70,000 GVW, and
machines of a similar nature.

Effective Period: 7/1/2019 - 6/30/2020

Wage Rate per Hour: \$59.33

Supplemental Benefit Rate per Hour: \$39.74

Supplemental Note: \$72.08 on overtime

Engineer - Building Work Oilers II

Oilers on Crawler Cranes, Backhoes, Trenching Machines, Gunite Machines, Compressors (three or more in
Battery).

Effective Period: 7/1/2019 - 6/30/2020

Wage Rate per Hour: \$43.78

Supplemental Benefit Rate per Hour: \$39.74

Supplemental Note: \$72.08 on overtime

Overtime Description

On jobs of more than one shift, if an Employee fails to report for work through any cause over which the
Employer has no control, the Employee on duty will continue to work at the rate of single time.

Overtime

Double time the regular rate after an 8 hour day.

Double time the regular time rate for Saturday.

Double time the regular rate for Sunday.

Double time the regular rate for work on the following holiday(s).

Paid Holidays

New Year's Day

Lincoln's Birthday

President's Day

Memorial Day

Independence Day

Labor Day

Columbus Day

Veteran's Day

Thanksgiving Day

Christmas Day

Employees must work at least one day in the payroll week in which the holiday occurs to receive the paid holiday

Shift Rates

Off Shift: double time the regular hourly rate.

(Local #15)

OFFICE OF THE COMPTROLLER, CITY OF NEW YORK
CONSTRUCTION WORKER PREVAILING WAGE SCHEDULE

ENGINEER - CITY SURVEYOR AND CONSULTANT

Party Chief

Effective Period: 7/1/2019 - 6/30/2020

Wage Rate per Hour: \$40.41

Supplemental Benefit Rate per Hour: \$22.75

Supplemental Note: Overtime Benefit Rate - \$27.25 per hour (time & one half) \$31.75 per hour (double time).

Instrument Person

Effective Period: 7/1/2019 - 6/30/2020

Wage Rate per Hour: \$33.13

Supplemental Benefit Rate per Hour: \$22.75

Supplemental Note: Overtime Benefit Rate - \$27.25 per hour (time & one half) \$31.75 per hour (double time).

Rodperson

Effective Period: 7/1/2019 - 6/30/2020

Wage Rate per Hour: \$28.54

Supplemental Benefit Rate per Hour: \$22.75

Supplemental Note: Overtime Benefit Rate - \$27.25 per hour (time & one half) \$31.75 per hour (double time).

Overtime Description

Time and one half the regular rate after an 8 hour day, Time and one half the regular rate for Saturday for the first eight hours worked, Double time the regular time rate for Saturday for work performed in excess of eight hours, Double time the regular rate for Sunday and Double time the regular rate for work on a holiday.

Paid Holidays

New Year's Day

Lincoln's Birthday

President's Day

Memorial Day

Independence Day

Labor Day

Columbus Day

Veteran's Day

Thanksgiving Day

Day after Thanksgiving

Christmas Day

Employees must work at least one day in the payroll week in which the holiday occurs to receive the paid holiday

(Operating Engineer Local #15-D)

OFFICE OF THE COMPTROLLER, CITY OF NEW YORK
CONSTRUCTION WORKER PREVAILING WAGE SCHEDULE

ENGINEER - FIELD (BUILDING CONSTRUCTION)
(Construction of Building Projects, Concrete Superstructures, etc.)

Field Engineer - BC Party Chief

Effective Period: 7/1/2019 - 6/30/2020

Wage Rate per Hour: **\$65.44**

Supplemental Benefit Rate per Hour: **\$35.12**

Supplemental Note: Overtime Benefit Rate - \$49.33 per hour (time & one half) \$63.54 per hour (double time).

Field Engineer - BC Instrument Person

Effective Period: 7/1/2019 - 6/30/2020

Wage Rate per Hour: **\$50.83**

Supplemental Benefit Rate per Hour: **\$35.12**

Supplemental Note: Overtime Benefit Rate - \$49.33 per hour (time & one half) \$63.54 per hour (double time).

Field Engineer - BC Rodperson

Effective Period: 7/1/2019 - 6/30/2020

Wage Rate per Hour: **\$32.84**

Supplemental Benefit Rate per Hour: **\$35.12**

Supplemental Note: Overtime Benefit Rate - \$49.33 per hour (time & one half) \$63.54 per hour (double time).

Overtime Description

Time and one half the regular rate after a 7 hour work and time and one half the regular rate for Saturday for the first seven hours worked, Double time the regular time rate for Saturday for work performed in excess of seven hours, Double time the regular rate for Sunday and Double time the regular rate for work on a holiday.

Paid Holidays

New Year's Day
President's Day
Good Friday
Memorial Day
Independence Day
Labor Day
Columbus Day
Veteran's Day
Thanksgiving Day
Christmas Day

Employees must work at least one day in the payroll week in which the holiday occurs to receive the paid holiday

(Operating Engineer Local #15-D)

OFFICE OF THE COMPTROLLER, CITY OF NEW YORK
CONSTRUCTION WORKER PREVAILING WAGE SCHEDULE

ENGINEER - FIELD (HEAVY CONSTRUCTION)
(Construction of Roads, Tunnels, Bridges, Sewers, Building Foundations,
Engineering Structures etc.)

Field Engineer - HC Party Chief

Effective Period: 7/1/2019 - 6/30/2020

Wage Rate per Hour: \$74.18

Supplemental Benefit Rate per Hour: \$36.51

Supplemental Note: Overtime benefit rate - \$51.29 per hour (time & one half), \$66.07 per hour (double time).

Field Engineer - HC Instrument Person

Effective Period: 7/1/2019 - 6/30/2020

Wage Rate per Hour: \$54.47

Supplemental Benefit Rate per Hour: \$36.51

Supplemental Note: Overtime benefit rate - \$51.29 per hour (time & one half), \$66.07 per hour (double time).

Field Engineer - HC Rodperson

Effective Period: 7/1/2019 - 6/30/2020

Wage Rate per Hour: \$45.70

Supplemental Benefit Rate per Hour: \$36.51

Supplemental Note: Overtime benefit rate - \$51.29 per hour (time & one half), \$66.07 per hour (double time).

Overtime Description

Time and one half the regular rate after an 8 hour day, Time and one half the regular rate for Saturday for the first eight hours worked, Double time the regular time rate for Saturday for work performed in excess of eight hours, Double time the regular rate for Sunday and Double time the regular rate for work on a holiday.

Paid Holidays

New Year's Day

Lincoln's Birthday

President's Day

Memorial Day

Independence Day

Labor Day

Columbus Day

Veteran's Day

Thanksgiving Day

Christmas Day

Employees must work at least one day in the payroll week in which the holiday occurs to receive the paid holiday

(Operating Engineer Local #15-D)

OFFICE OF THE COMPTROLLER, CITY OF NEW YORK
CONSTRUCTION WORKER PREVAILING WAGE SCHEDULE

ENGINEER - FIELD (STEEL ERECTION)

Field Engineer - Steel Erection Party Chief

Effective Period: 7/1/2019 - 6/30/2020

Wage Rate per Hour: **\$69.15**

Supplemental Benefit Rate per Hour: **\$36.01**

Supplemental Note: Overtime benefit rate - \$50.54 per hour (time & one half), \$65.07 per hour (double time).

Field Engineer - Steel Erection Instrument Person

Effective Period: 7/1/2019 - 6/30/2020

Wage Rate per Hour: **\$53.88**

Supplemental Benefit Rate per Hour: **\$36.01**

Supplemental Note: Overtime benefit rate - \$50.54 per hour (time & one half), \$65.07 per hour (double time).

Field Engineer - Steel Erection Rodperson

Effective Period: 7/1/2019 - 6/30/2020

Wage Rate per Hour: **\$36.04**

Supplemental Benefit Rate per Hour: **\$36.01**

Supplemental Note: Overtime benefit rate - \$50.54 per hour (time & one half), \$65.07 per hour (double time).

Overtime Description

Time and one half the regular rate for Saturday for the first eight hours worked.
Double time the regular rate for Saturday for work performed in excess of eight hours.

Overtime

Time and one half the regular rate after an 8 hour day.
Double time the regular rate for Sunday.
Double time the regular rate for work on the following holiday(s).

Paid Holidays

New Year's Day
Lincoln's Birthday
President's Day
Memorial Day
Independence Day
Labor Day
Columbus Day
Veteran's Day
Thanksgiving Day
Christmas Day

Employees must work at least one day in the payroll week in which the holiday occurs to receive the paid holiday

(Operating Engineer Local #15-D)

OFFICE OF THE COMPTROLLER, CITY OF NEW YORK
CONSTRUCTION WORKER PREVAILING WAGE SCHEDULE

ENGINEER - OPERATING

Operating Engineer - Road & Heavy Construction I

Back Filling Machines, Cranes, Mucking Machines and Dual Drum Paver.

Effective Period: 7/1/2019 - 6/30/2020
Wage Rate per Hour: \$81.17
Supplemental Benefit Rate per Hour: \$32.95
Supplemental Note: \$59.95 overtime hours
Shift Wage Rate: \$129.87

Operating Engineer - Road & Heavy Construction II

Backhoes, Power Shovels, Hydraulic Clam Shells, Steel Erection, Moles and machines of a similar nature.

Effective Period: 7/1/2019 - 6/30/2020
Wage Rate per Hour: \$84.01
Supplemental Benefit Rate per Hour: \$32.95
Supplemental Note: \$59.95 overtime hours
Shift Wage Rate: \$134.42

Operating Engineer - Road & Heavy Construction III

Mine Hoists, Cranes, etc. (Used as Mine Hoists)

Effective Period: 7/1/2019 - 6/30/2020
Wage Rate per Hour: \$86.69
Supplemental Benefit Rate per Hour: \$32.95
Supplemental Note: \$59.95 overtime hours
Shift Wage Rate: \$138.70

Operating Engineer - Road & Heavy Construction IV

Gradealls, Keystones, Cranes on land or water (with digging buckets), Bridge Cranes, Vermeer Cutter and machines of a similar nature, Trenching Machines.

Effective Period: 7/1/2019 - 6/30/2020
Wage Rate per Hour: \$84.62
Supplemental Benefit Rate per Hour: \$32.95
Supplemental Note: \$59.95 overtime hours
Shift Wage Rate: \$135.39

Operating Engineer - Road & Heavy Construction V

Pile Drivers & Rigs (employing Dock Builder foreperson): Derrick Boats, Tunnel Shovels.

OFFICE OF THE COMPTROLLER, CITY OF NEW YORK
CONSTRUCTION WORKER PREVAILING WAGE SCHEDULE

Effective Period: 7/1/2019 - 6/30/2020
Wage Rate per Hour: **\$82.96**
Supplemental Benefit Rate per Hour: **\$32.95**
Supplemental Note: **\$59.95** overtime hours
Shift Wage Rate: **\$132.74**

Operating Engineer - Road & Heavy Construction VI

Mixers (Concrete with loading attachment), Concrete Pavers, Cableways, Land Derricks, Power Houses (Low Air Pressure Units).

Effective Period: 7/1/2019 - 6/30/2020
Wage Rate per Hour: **\$78.85**
Supplemental Benefit Rate per Hour: **\$32.95**
Supplemental Note: **\$59.95** overtime hours
Shift Wage Rate: **\$126.16**

Operating Engineer - Road & Heavy Construction VII

Barrier Movers , Barrier Transport and Machines of a Similar Nature.

Effective Period: 7/1/2019 - 6/30/2020
Wage Rate per Hour: **\$63.81**
Supplemental Benefit Rate per Hour: **\$32.95**
Supplemental Note: **\$59.95** overtime hours
Shift Wage Rate: **\$102.10**

Operating Engineer - Road & Heavy Construction VIII

Utility Compressors

Effective Period: 7/1/2019 - 6/30/2020
Wage Rate per Hour: **\$49.67**
Supplemental Benefit Rate per Hour: **\$32.95**
Supplemental Note: **\$59.95** overtime hours
Shift Wage Rate: **\$62.44**

Operating Engineer - Road & Heavy Construction IX

Horizontal Boring Rig

Effective Period: 7/1/2019 - 6/30/2020
Wage Rate per Hour: **\$75.02**
Supplemental Benefit Rate per Hour: **\$32.95**
Supplemental Note: **\$59.95** overtime hours
Shift Wage Rate: **\$120.03**

Operating Engineer - Road & Heavy Construction X

Elevators (manually operated as personnel hoist).

OFFICE OF THE COMPTROLLER, CITY OF NEW YORK
CONSTRUCTION WORKER PREVAILING WAGE SCHEDULE

Effective Period: 7/1/2019 - 6/30/2020
Wage Rate per Hour: \$69.01
Supplemental Benefit Rate per Hour: \$32.95
Supplemental Note: \$59.95 overtime hours
Shift Wage Rate: \$110.42

Operating Engineer - Road & Heavy Construction XI

Compressors (Portable 3 or more in battery), Driving of Truck Mounted Compressors, Well-point Pumps, Tugger Machines Well Point Pumps, Churn Drill.

Effective Period: 7/1/2019 - 6/30/2020
Wage Rate per Hour: \$53.74
Supplemental Benefit Rate per Hour: \$32.95
Supplemental Note: \$59.95 overtime hours
Shift Wage Rate: \$85.98

Operating Engineer - Road & Heavy Construction XII

All Drills and Machines of a similar nature.

Effective Period: 7/1/2019 - 6/30/2020
Wage Rate per Hour: \$79.68
Supplemental Benefit Rate per Hour: \$32.95
Supplemental Note: \$59.95 overtime hours
Shift Wage Rate: \$127.49

Operating Engineer - Road & Heavy Construction XIII

Concrete Pumps, Concrete Plant, Stone Crushers, Double Drum Hoist, Power Houses (other than above).

Effective Period: 7/1/2019 - 6/30/2020
Wage Rate per Hour: \$77.19
Supplemental Benefit Rate per Hour: \$32.95
Supplemental Note: \$59.95 overtime hours
Shift Wage Rate: \$123.50

Operating Engineer - Road & Heavy Construction XIV

Concrete Mixer

Effective Period: 7/1/2019 - 6/30/2020
Wage Rate per Hour: \$73.82
Supplemental Benefit Rate per Hour: \$32.95
Supplemental Note: \$59.95 overtime hours
Shift Wage Rate: \$118.11

Operating Engineer - Road & Heavy Construction XV

OFFICE OF THE COMPTROLLER, CITY OF NEW YORK
CONSTRUCTION WORKER PREVAILING WAGE SCHEDULE

Compressors (Portable Single or two in Battery, not over 100 feet apart); Pumps (River Cofferdam) and Welding Machines, Push Button Machines, All Engines Irrespective of Power (Power-Pac) used to drive auxiliary equipment, Air, Hydraulic, etc.

Effective Period: 7/1/2019 - 6/30/2020

Wage Rate per Hour: **\$49.99**

Supplemental Benefit Rate per Hour: **\$32.95**

Supplemental Note: **\$59.95** overtime hours

Shift Wage Rate: **\$79.98**

Operating Engineer - Road & Heavy Construction XVI

Concrete Breaking Machines, Hoists (Single Drum), Load Masters, Locomotives (over ten tons) and Dinkies over ten tons, Hydraulic Crane-Second Engineer.

Effective Period: 7/1/2019 - 6/30/2020

Wage Rate per Hour: **\$70.53**

Supplemental Benefit Rate per Hour: **\$32.95**

Supplemental Note: **\$59.95** overtime hours

Shift Wage Rate: **\$112.85**

Operating Engineer - Road & Heavy Construction XVII

On-Site concrete plant engineer, On-site Asphalt Plant Engineer, and Vibratory console.

Effective Period: 7/1/2019 - 6/30/2020

Wage Rate per Hour: **\$71.06**

Supplemental Benefit Rate per Hour: **\$32.95**

Supplemental Note: **\$59.95** overtime hours

Shift Wage Rate: **\$113.70**

Operating Engineer - Road & Heavy Construction XVIII

Tower Crane

Effective Period: 7/1/2019 - 6/30/2020

Wage Rate per Hour: **\$101.71**

Supplemental Benefit Rate per Hour: **\$32.95**

Supplemental Note: **\$59.95** overtime hours

Shift Wage Rate: **\$162.74**

Operating Engineer - Paving I

Asphalt Spreaders, Autogrades (C.M.I.), Roto/Mil

Effective Period: 7/1/2019 - 6/30/2020

Wage Rate per Hour: **\$78.85**

Supplemental Benefit Rate per Hour: **\$32.95**

Supplemental Note: **\$59.95** overtime hours

OFFICE OF THE COMPTROLLER, CITY OF NEW YORK
CONSTRUCTION WORKER PREVAILING WAGE SCHEDULE

Shift Wage Rate: \$126.16

Operating Engineer - Paving II

Asphalt Roller

Effective Period: 7/1/2019 - 6/30/2020

Wage Rate per Hour: \$76.83

Supplemental Benefit Rate per Hour: \$32.95

Supplemental Note: \$59.95 overtime hours

Shift Wage Rate: \$122.93

Operating Engineer - Paving III

Asphalt Plants

Effective Period: 7/1/2019 - 6/30/2020

Wage Rate per Hour: \$65.08

Supplemental Benefit Rate per Hour: \$32.95

Supplemental Note: \$59.95 overtime hours

Shift Wage Rate: \$104.13

Operating Engineer - Concrete I

Cranes

Effective Period: 7/1/2019 - 6/30/2020

Wage Rate per Hour: \$84.25

Supplemental Benefit Rate per Hour: \$32.95

Supplemental Note: \$59.95 overtime hours

Operating Engineer - Concrete II

Compressors

Effective Period: 7/1/2019 - 6/30/2020

Wage Rate per Hour: \$50.37

Supplemental Benefit Rate per Hour: \$32.95

Supplemental Note: \$59.95 overtime hours

Operating Engineer - Concrete III

Micro-traps (Negative Air Machines), Vac-All Remediation System.

Effective Period: 7/1/2019 - 6/30/2020

Wage Rate per Hour: \$67.45

Supplemental Benefit Rate per Hour: \$32.95

Supplemental Note: \$59.95 overtime hours

OFFICE OF THE COMPTROLLER, CITY OF NEW YORK
CONSTRUCTION WORKER PREVAILING WAGE SCHEDULE

Operating Engineer - Steel Erection I

Three Drum Derricks

Effective Period: 7/1/2019 - 6/30/2020
Wage Rate per Hour: \$87.14
Supplemental Benefit Rate per Hour: \$32.95
Supplemental Note: \$59.95 overtime hours
Shift Wage Rate: \$139.42

Operating Engineer - Steel Erection II

Cranes, 2 Drum Derricks, Hydraulic Cranes, Fork Lifts and Boom Trucks.

Effective Period: 7/1/2019 - 6/30/2020
Wage Rate per Hour: \$83.75
Supplemental Benefit Rate per Hour: \$32.95
Supplemental Note: \$59.95 overtime hours
Shift Wage Rate: \$134.00

Operating Engineer - Steel Erection III

Compressors, Welding Machines.

Effective Period: 7/1/2019 - 6/30/2020
Wage Rate per Hour: \$49.95
Supplemental Benefit Rate per Hour: \$32.95
Supplemental Note: \$59.95 overtime hours
Shift Wage Rate: \$79.92

Operating Engineer - Steel Erection IV

Compressors - Not Combined with Welding Machine.

Effective Period: 7/1/2019 - 6/30/2020
Wage Rate per Hour: \$47.58
Supplemental Benefit Rate per Hour: \$32.95
Supplemental Note: \$59.95 overtime hours
Shift Wage Rate: \$76.13

Operating Engineer - Building Work I

Forklifts, Plaster (Platform machine), Plaster Bucket, Concrete Pump and all other equipment used for hoisting material.

Effective Period: 7/1/2019 - 6/30/2020
Wage Rate per Hour: \$69.51
Supplemental Benefit Rate per Hour: \$32.95
Supplemental Note: \$59.95 overtime hours

OFFICE OF THE COMPTROLLER, CITY OF NEW YORK
CONSTRUCTION WORKER PREVAILING WAGE SCHEDULE

Operating Engineer - Building Work II

Compressors, Welding Machines (Cutting Concrete-Tank Work), Paint Spraying, Sandblasting, Pumps (with the exclusion of Concrete Pumps), All Engines irrespective of Power (Power-Pac) used to drive Auxiliary Equipment, Air, Hydraulic, Jacking System, etc.

Effective Period: 7/1/2019 - 6/30/2020

Wage Rate per Hour: \$52.21

Supplemental Benefit Rate per Hour: \$32.95

Supplemental Note: \$59.95 overtime hours

Operating Engineer - Building Work III

Double Drum

Effective Period: 7/1/2019 - 6/30/2020

Wage Rate per Hour: \$79.02

Supplemental Benefit Rate per Hour: \$32.95

Supplemental Note: \$59.95 overtime hours

Operating Engineer - Building Work IV

Stone Derrick, Cranes, Hydraulic Cranes Boom Trucks.

Effective Period: 7/1/2019 - 6/30/2020

Wage Rate per Hour: \$83.68

Supplemental Benefit Rate per Hour: \$32.95

Supplemental Note: \$59.95 overtime hours

Operating Engineer - Building Work V

Dismantling and Erection of Cranes, Relief Engineer.

Effective Period: 7/1/2019 - 6/30/2020

Wage Rate per Hour: \$77.15

Supplemental Benefit Rate per Hour: \$32.95

Supplemental Note: \$59.95 overtime hours

Operating Engineer - Building Work VI

4 Pole Hoist, Single Drum Hoists.

Effective Period: 7/1/2019 - 6/30/2020

Wage Rate per Hour: \$76.35

Supplemental Benefit Rate per Hour: \$32.95

Supplemental Note: \$59.95 overtime hours

Operating Engineer - Building Work VII

Rack & Pinion and House Cars

OFFICE OF THE COMPTROLLER, CITY OF NEW YORK
CONSTRUCTION WORKER PREVAILING WAGE SCHEDULE

Effective Period: 7/1/2019 - 6/30/2020

Wage Rate per Hour: \$60.84

Supplemental Benefit Rate per Hour: \$32.95

Supplemental Note: \$59.95 overtime hours

For New House Car projects Wage Rate per Hour \$48.70

Overtime Description

On jobs of more than one shift, if an Employee fails to report for work through any cause over which the Employer has no control, the Employee on duty will continue to work at the rate of single time.

For House Cars and Rack & Pinion only: Overtime paid at time and one-half for all hours in excess of eight hours in a day, Saturday, Sunday and Holidays worked.

Overtime

Double time the regular rate after an 8 hour day.

Double time the regular time rate for Saturday.

Double time the regular rate for Sunday.

Double time the regular rate for work on the following holiday(s).

Paid Holidays

New Year's Day

Lincoln's Birthday

President's Day

Memorial Day

Independence Day

Labor Day

Columbus Day

Veteran's Day

Thanksgiving Day

Day after Thanksgiving

Christmas Day

Employees must work at least one day in the payroll week in which the holiday occurs to receive the paid holiday

Shift Rates

For Steel Erection Only: Shifts may be worked at the single time rate at other than the regular working hours (8:00 A.M. to 4:30 P.M.) on the following work ONLY: Heavy construction jobs on work below the street level, over railroad tracks and on building jobs.

(Operating Engineer Local #14)

FLOOR COVERER

(Interior vinyl composition tile, sheath vinyl linoleum and wood parquet tile including site preparation and synthetic turf not including site preparation)

OFFICE OF THE COMPTROLLER, CITY OF NEW YORK
CONSTRUCTION WORKER PREVAILING WAGE SCHEDULE

Floor Coverer

Effective Period: 7/1/2019 - 6/30/2020

Wage Rate per Hour: \$50.50

Supplemental Benefit Rate per Hour: \$45.98

Overtime

Time and one half the regular rate after an 8 hour day.

Time and one half the regular rate for Saturday.

Double time the regular rate for Sunday.

Overtime Holidays

Double time the regular rate for work on the following holiday(s).

New Year's Day

President's Day

Memorial Day

Independence Day

Labor Day

Columbus Day

Presidential Election Day

Thanksgiving Day

Day after Thanksgiving

Christmas Day

Paid Holidays

1/2 day on Christmas Eve if work is performed in the A.M.

1/2 day on New Year's Eve if work is performed in the A.M.

Shift Rates

Two shifts may be utilized with the first shift working 8 a.m. to the end of the shift at straight time rate of pay. The wage rate for the second shift consisting of 7 hours shall be paid at 114.29% of straight time wage rate. The wage rate for the second shift consisting of 8 hours shall be paid 112.5% of the straight time wage rate. There must be a first shift to work the second shift.

(Carpenters District Council)

GLAZIER

(New Construction, Remodeling, and Alteration)

Glazier

Effective Period: 7/1/2019 - 6/30/2020

Wage Rate per Hour: \$46.05

Supplemental Benefit Rate per Hour: \$43.39

Supplemental Note: Supplemental Benefit Overtime Rate: \$65.10

OFFICE OF THE COMPTROLLER, CITY OF NEW YORK
CONSTRUCTION WORKER PREVAILING WAGE SCHEDULE

Overtime

Time and one half the regular rate after an 8 hour day.
Time and one half the regular rate for Saturday.
Time and one half the regular rate for Sunday.

Overtime Holidays

Time and one half the regular rate for work on the following holiday(s).

New Year's Day
President's Day
Memorial Day
Independence Day
Thanksgiving Day
Day after Thanksgiving
Christmas Day

Paid Holidays

None

Shift Rates

Shifts shall be any 8 consecutive hours after the normal working day for which the Glazier shall receive 9 hours pay for 8 hours worked.

(Local #1281)

GLAZIER - REPAIR & MAINTENANCE

(For the Installation of Glass - All repair and maintenance work on a particular building, whenever performed, where the total cumulative contract value is under \$141,750)

Craft Jurisdiction for repair, maintenance and fabrication

Plate glass replacement, Residential glass replacement, Residential mirrors and shower doors, Storm windows and storm doors, Residential replacement windows, Herculite door repairs, Door closer repairs, Retrofit apartment house (non-commercial buildings), Glass tinting.

Effective Period: 7/1/2019 - 6/30/2020

Wage Rate per Hour: \$25.64

Supplemental Benefit Rate per Hour: \$22.29

Overtime

Time and one half the regular rate after an 8 hour day.
Time and one half the regular rate for Sunday.
Time and one half the regular rate for work on the following holiday(s).

OFFICE OF THE COMPTROLLER, CITY OF NEW YORK
CONSTRUCTION WORKER PREVAILING WAGE SCHEDULE

Time and one half the regular hourly rate after 40 hours in any work week.

Paid Holidays

New Year's Day
President's Day
Memorial Day
Independence Day
Labor Day
Thanksgiving Day
Day after Thanksgiving
Christmas Day

Employees must work at least one day in the payroll week in which the holiday occurs to receive the paid holiday

(Local #1281)

HAZARDOUS MATERIAL HANDLER

(Removal, abatement, encapsulation or decontamination of asbestos, lead, mold, or other toxic or hazardous waste/materials)

Handler

Effective Period: 7/1/2019 - 6/30/2020

Wage Rate per Hour: \$36.50

Supplemental Benefit Rate per Hour: \$16.45

Overtime

Time and one half the regular rate after an 8 hour day.

Time and one half the regular rate for Sunday.

Time and one half the regular hourly rate after 40 hours in any work week.

Overtime Holidays

Time and one half the regular rate for work on the following holiday(s).

New Year's Day
Good Friday
Memorial Day
Independence Day
Labor Day
Thanksgiving Day
Christmas Day
Easter

Paid Holidays

None

OFFICE OF THE COMPTROLLER, CITY OF NEW YORK
CONSTRUCTION WORKER PREVAILING WAGE SCHEDULE

(Local #78 and Local #12A)

HEAT AND FROST INSULATOR

Heat & Frost Insulator

Effective Period: 7/1/2019 - 6/30/2020

Wage Rate per Hour: **\$61.46**

Supplemental Benefit Rate per Hour: **\$40.46**

Overtime Description

Double time shall be paid for supplemental benefits during overtime work.
8th hour paid at time and one half.

Overtime

Double time the regular rate after an 8 hour day.
Double time the regular time rate for Saturday.
Double time the regular rate for Sunday.

Overtime Holidays

Double time the regular rate for work on the following holiday(s).

New Year's Day
Martin Luther King Jr. Day
President's Day
Memorial Day
Independence Day
Columbus Day
Veteran's Day
Thanksgiving Day
Day after Thanksgiving
Christmas Day

Triple time the regular rate for work on the following holiday(s).
Labor Day

Paid Holidays

None

Shift Rates

The first shift shall work seven hours at the regular straight time rate. The second and third shift shall work seven hours the regular straight time hourly rate plus a fourteen percent wage and benefit premium.

(Local #12) (BCA)

OFFICE OF THE COMPTROLLER, CITY OF NEW YORK
CONSTRUCTION WORKER PREVAILING WAGE SCHEDULE

**HOUSE WRECKER
(TOTAL DEMOLITION)**

House Wrecker - Tier A

On all work sites the first, second, eleventh and every third House Wrecker thereafter will be Tier A House Wreckers (i.e. 1st, 2nd, 11th, 14th etc). Other House Wreckers may be Tier B House Wreckers.

Effective Period: 7/1/2019 - 6/30/2020
Wage Rate per Hour: **\$37.18**
Supplemental Benefit Rate per Hour: **\$29.77**

House Wrecker - Tier B

Effective Period: 7/1/2019 - 6/30/2020
Wage Rate per Hour: **\$26.41**
Supplemental Benefit Rate per Hour: **\$22.18**

Overtime

Time and one half the regular rate after an 8 hour day.
Time and one half the regular rate for Saturday.
Double time the regular rate for Sunday.

Overtime Holidays

Double time the regular rate for work on the following holiday(s).
New Year's Day
President's Day
Memorial Day
Independence Day
Labor Day
Thanksgiving Day
Christmas Day.

Paid Holidays

None

(Mason Tenders District Council)

IRON WORKER - ORNAMENTAL

Iron Worker - Ornamental

Effective Period: 7/1/2019 - 6/30/2020

OFFICE OF THE COMPTROLLER, CITY OF NEW YORK
CONSTRUCTION WORKER PREVAILING WAGE SCHEDULE

Wage Rate per Hour: **\$45.15**

Supplemental Benefit Rate per Hour: **\$55.62**

Supplemental Note: Supplemental benefits are to be paid at the applicable overtime rate when overtime is in effect.

Overtime Description

Time and one half the regular rate after a 7 hour day for a maximum of two hours on any regular work day (the 8th and 9th hour) and double time shall be paid for all work on a regular work day thereafter, time and one half the regular rate for Saturday for the first seven hours of work and double time shall be paid for all work on a Saturday thereafter.

Overtime

Double time the regular rate for Sunday.

Overtime Holidays

Double time the regular rate for work on the following holiday(s).

New Year's Day
President's Day
Memorial Day
Independence Day
Labor Day
Thanksgiving Day
Christmas Day

Paid Holidays

None

Shift Rates

For off shift work - 8 hours pay for 7 hours of work. When two or three shifts are employed on a job, Monday through Friday, the workday for each shift shall be seven hours and paid for ten and one-half hours at the single time rate. When two or three shifts are worked on Saturday, Sunday or holidays, each shift shall be seven hours and paid fifteen and three-quarters hours.

(Local #580)

IRON WORKER - STRUCTURAL

Iron Worker - Structural

Effective Period: 7/1/2019 - 6/30/2020

Wage Rate per Hour: **\$51.05**

Supplemental Benefit Rate per Hour: **\$76.89**

Supplemental Note: Supplemental benefits are to be paid at the applicable overtime rate when overtime is in effect.

Overtime Description

OFFICE OF THE COMPTROLLER, CITY OF NEW YORK
CONSTRUCTION WORKER PREVAILING WAGE SCHEDULE

Monday through Friday- the first eight hours are paid at straight time, the 9th and 10th hours are paid at time and one-half the regular rate, all additional weekday overtime is paid at double the regular rate. Saturdays- the first eight hours are paid at time and one-half the regular rate, double time thereafter. Sunday-all shifts are paid at double time.

Overtime

Time and one half the regular rate after an 8 hour day.

Time and one half the regular rate for Saturday.

Double time the regular rate for Sunday.

Overtime Holidays

Double time the regular rate for work on the following holiday(s).

New Year's Day

President's Day

Memorial Day

Independence Day

Labor Day

Thanksgiving Day

Christmas Day

Paid Holidays

1/2 day on Christmas Eve if work is performed in the A.M.

1/2 day on New Year's Eve if work is performed in the A.M.

Shift Rates

Monday through Friday - First Shift: First eight hours are paid at straight time, the 9th & 10th hours are paid at time and a half, double time paid thereafter. Second and third Shifts: First eight hours are paid at time and one-half, double time thereafter. Saturdays: All shifts, first eight hours paid at time and one-half, double time thereafter: Sunday all shifts are paid at double time.

(Local #40 & #361)

LABORER

(Foundation, Concrete, Excavating, Street Pipe Layer and Common)

Laborer

Excavation and foundation work for buildings, heavy construction, engineering work, and hazardous waste removal in connection with the above work. Landscaping tasks in connection with heavy construction work, engineering work and building projects. Projects include, but are not limited to pollution plants, sewers, parks, subways, bridges, highways, etc.

Effective Period: 7/1/2019 - 6/30/2020

Wage Rate per Hour: \$42.65

Supplemental Benefit Rate per Hour: \$44.48

OFFICE OF THE COMPTROLLER, CITY OF NEW YORK
CONSTRUCTION WORKER PREVAILING WAGE SCHEDULE

Overtime

Time and one half the regular rate after an 8 hour day.
Time and one half the regular rate for Saturday.
Double time the regular rate for Sunday.

Overtime Holidays

Double time the regular rate for work on the following holiday(s).

New Year's Day
Memorial Day
Independence Day
Labor Day
Columbus Day
Thanksgiving Day
Christmas Day

Paid Holidays

Labor Day
Thanksgiving Day

Shift Rates

When two shifts are employed, single time rate shall be paid for each shift. When three shifts are found necessary, each shift shall work seven and one half hours (7 ½), but shall be paid for eight (8) hours of labor, and be permitted one half hour for lunch.

(Local #731)

LANDSCAPING

(Landscaping tasks, as well as tree pruning, tree removing, spraying and maintenance in connection with the planting of street trees and the planting of trees in city parks but not when such activities are performed as part of, or in connection with, other construction or reconstruction projects.)

Landscaper (Year 6 and above)

Effective Period: 7/1/2019 - 6/30/2020
Wage Rate per Hour: \$31.75
Supplemental Benefit Rate per Hour: \$16.05

Landscaper (Year 3 - 5)

Effective Period: 7/1/2019 - 6/30/2020
Wage Rate per Hour: \$30.72
Supplemental Benefit Rate per Hour: \$16.05

OFFICE OF THE COMPTROLLER, CITY OF NEW YORK
CONSTRUCTION WORKER PREVAILING WAGE SCHEDULE

Landscaper (up to 3 years)

Effective Period: 7/1/2019 - 6/30/2020
Wage Rate per Hour: \$28.14
Supplemental Benefit Rate per Hour: \$16.05

Groundperson

Effective Period: 7/1/2019 - 6/30/2020
Wage Rate per Hour: \$28.14
Supplemental Benefit Rate per Hour: \$16.05

Tree Remover / Pruner

Effective Period: 7/1/2019 - 6/30/2020
Wage Rate per Hour: \$36.92
Supplemental Benefit Rate per Hour: \$16.05

Landscaper Sprayer (Pesticide Applicator)

Effective Period: 7/1/2019 - 6/30/2020
Wage Rate per Hour: \$26.59
Supplemental Benefit Rate per Hour: \$16.05

Watering - Plant Maintainer

Effective Period: 7/1/2019 - 6/30/2020
Wage Rate per Hour: \$21.40
Supplemental Benefit Rate per Hour: \$16.05

Overtime Description

For all overtime work performed, supplemental benefits shall include an additional seventy-five (\$0.75) cents per hour.

Overtime

Time and one half the regular rate after an 8 hour day.
Time and one half the regular rate for Saturday.
Double time the regular rate for Sunday.
Time and one half the regular rate for work on a holiday plus the day's pay.

Paid Holidays

New Year's Day
Memorial Day
Independence Day
Labor Day
Thanksgiving Day
Christmas Day

Shift Rates

OFFICE OF THE COMPTROLLER, CITY OF NEW YORK
CONSTRUCTION WORKER PREVAILING WAGE SCHEDULE

Work performed on a 4pm to 12am shift has a 15% differential. Work performed on a 12am to 8am shift has a 20% differential.

(Local #175)

MARBLE MECHANIC

Marble Setter

Effective Period: 7/1/2019 - 6/30/2020
Wage Rate per Hour: **\$54.44**
Supplemental Benefit Rate per Hour: **\$40.77**

Marble Finisher

Effective Period: 7/1/2019 - 6/30/2020
Wage Rate per Hour: **\$42.86**
Supplemental Benefit Rate per Hour: **\$38.22**

Marble Polisher

Effective Period: 7/1/2019 - 6/30/2020
Wage Rate per Hour: **\$39.81**
Supplemental Benefit Rate per Hour: **\$30.35**

Marble Maintenance Finisher

Effective Period: 7/1/2019 - 6/30/2020
Wage Rate per Hour: **\$24.31**
Supplemental Benefit Rate per Hour: **\$13.34**

Overtime Description

Supplemental Benefit contributions are to be made at the applicable overtime rates. Time and one half the regular rate after a 7 hour day or time and one half the regular rate after an 8 hour day - chosen by Employer at the start of the project and then would last for the full duration of the project.

Overtime

Time and one half the regular rate for Saturday.
Double time the regular rate for Sunday.

Overtime Holidays

Double time the regular rate for work on the following holiday(s).
New Year's Day
President's Day
Good Friday

OFFICE OF THE COMPTROLLER, CITY OF NEW YORK
CONSTRUCTION WORKER PREVAILING WAGE SCHEDULE

Memorial Day
Independence Day
Labor Day
Columbus Day
Veteran's Day
Thanksgiving Day
Day after Thanksgiving
Christmas Day

Paid Holidays

None

(Local #7)

MASON TENDER

Mason Tender

Effective Period: 7/1/2019 - 6/30/2020

Wage Rate per Hour: **\$38.40**

Supplemental Benefit Rate per Hour: **\$31.04**

Overtime

Time and one half the regular rate after an 8 hour day.

Time and one half the regular rate for Saturday.

Double time the regular rate for Sunday.

Saturday may be used as a make-up day at straight time when a day is lost during that week to inclement weather.

Overtime Holidays

Double time the regular rate for work on the following holiday(s).

New Year's Day

President's Day

Memorial Day

Independence Day

Labor Day

Thanksgiving Day

Christmas Day

Paid Holidays

None

Shift Rates

The employer may work two (2) shifts with the first shift at the straight time wage rate and the second shift receiving eight (8) hours paid for seven (7) hours work at the straight time wage rate. When it is not possible to conduct alteration work during regular working hours in a building occupied by tenants, the rule for the second shift will apply.

OFFICE OF THE COMPTROLLER, CITY OF NEW YORK
CONSTRUCTION WORKER PREVAILING WAGE SCHEDULE

(Local #79)

MASON TENDER (INTERIOR DEMOLITION WORKER)

Mason Tender Tier A

Tier A Interior Demolition Worker performs all burning, chopping, and other technically skilled tasks related to interior demolition work.

Effective Period: 7/1/2019 - 6/30/2020

Wage Rate per Hour: **\$36.44**

Supplemental Benefit Rate per Hour: **\$24.50**

Mason Tender Tier B

Tier B Interior Demolition Worker performs manual work and work incidental to demolition work, such as loading and carting of debris from the work site to an area where it can be loaded in to bins/trucks for removal. Also performs clean-up of the site when demolition is completed.

Effective Period: 7/1/2019 - 6/30/2020

Wage Rate per Hour: **\$25.63**

Supplemental Benefit Rate per Hour: **\$18.82**

Overtime

Time and one half the regular rate after an 8 hour day.
Time and one half the regular rate for Sunday.

Overtime Holidays

Double time the regular rate for work on the following holiday(s).

New Year's Day
President's Day
Memorial Day
Independence Day
Labor Day
Thanksgiving Day
Christmas Day

Paid Holidays

None

(Local #79)

OFFICE OF THE COMPTROLLER, CITY OF NEW YORK
CONSTRUCTION WORKER PREVAILING WAGE SCHEDULE

METALLIC LATHER

Metallic Lather

Effective Period: 7/1/2019 - 6/30/2020

Wage Rate per Hour: **\$46.23**

Supplemental Benefit Rate per Hour: **\$46.67**

Supplemental Note: Overtime Supplemental Benefit rate - \$57.92

Overtime Description

Overtime would be time and one half the regular rate after a seven (7) or eight (8) hours workday, which would be set at the start of the job.

Overtime

Time and one half the regular rate for Saturday.

Double time the regular rate for Sunday.

Overtime Holidays

Double time the regular rate for work on the following holiday(s).

New Year's Day

Washington's Birthday

Memorial Day

Independence Day

Labor Day

Columbus Day

Thanksgiving Day

Christmas Day

Paid Holidays

1/2 day on Christmas Eve if work is performed in the A.M.

1/2 day on New Year's Eve if work is performed in the A.M.

Shift Rates

There will be no shift differential paid on the first shift if more than one shift is employed. The shift differential will remain \$12/hour on the second and third shift for the first eight (8) hours if worked. There will be no pyramiding on overtime worked on second and third shifts. The time and one half (1.5x) rate will be against the base wage rate, not the shift differential

(Local #46)

MILLWRIGHT

Millwright

Effective Period: 7/1/2019 - 6/30/2020

PUBLISH DATE: 7/1/2019

EFFECTIVE PERIOD: JULY 1, 2019 THROUGH JUNE 30, 2020

Page 57 of 90

OFFICE OF THE COMPTROLLER, CITY OF NEW YORK
CONSTRUCTION WORKER PREVAILING WAGE SCHEDULE

Wage Rate per Hour: \$54.20

Supplemental Benefit Rate per Hour: \$53.81

Overtime

Time and one half the regular rate after an 8 hour day.

Time and one half the regular rate for Saturday.

Double time the regular rate for Sunday.

Saturday may be used as a make-up day at straight time when a day is lost during that week to inclement weather.

Overtime Holidays

Double time the regular rate for work on the following holiday(s).

New Year's Day

President's Day

Good Friday

Memorial Day

Independence Day

Labor Day

Columbus Day

Presidential Election Day

Thanksgiving Day

Christmas Day

Paid Holidays

1/2 day on Christmas Eve if work is performed in the A.M.

1/2 day on New Year's Eve if work is performed in the A.M.

Shift Rates

The first shift shall receive the straight time rate of pay. The second shift receives the straight time rate of pay plus fifteen (15%) per cent. Members of the second shift shall be allowed one half hour to eat, with this time being included in the hours of the workday established. There must be a first shift to work a second shift. All additional hours worked shall be paid at the time and one-half rate of pay plus fifteen (15%) per cent for weekday hours.

(Local #740)

MOSAIC MECHANIC

Mosaic Mechanic - Mosaic & Terrazzo Mechanic

Effective Period: 7/1/2019 - 6/30/2020

Wage Rate per Hour: \$49.91

Supplemental Benefit Rate per Hour: \$43.24

Mosaic Mechanic - Mosaic & Terrazzo Finisher

OFFICE OF THE COMPTROLLER, CITY OF NEW YORK
CONSTRUCTION WORKER PREVAILING WAGE SCHEDULE

Effective Period: 7/1/2019 - 6/30/2020
Wage Rate per Hour: \$48.31
Supplemental Benefit Rate per Hour: \$43.24

Mosaic Mechanic - Machine Operator Grinder

Effective Period: 7/1/2019 - 6/30/2020
Wage Rate per Hour: \$48.31
Supplemental Benefit Rate per Hour: \$43.24

Overtime

Time and one half the regular rate after a 7 hour day.
Time and one half the regular rate for Saturday.
Double time the regular rate for Sunday.

Overtime Holidays

Double time the regular rate for work on the following holiday(s).

New Year's Day
Washington's Birthday
Good Friday
Independence Day
Labor Day
Columbus Day
Veteran's Day
Thanksgiving Day
Day after Thanksgiving
Christmas Day

Paid Holidays

None

(Local #7)

PAINTER

Painter - Brush & Roller

Effective Period: 7/1/2019 - 6/30/2020
Wage Rate per Hour: \$43.00
Supplemental Benefit Rate per Hour: \$32.49
Supplemental Note: \$ 37.75 on overtime

Spray & Scaffold / Decorative / Sandblast

Effective Period: 7/1/2019 - 6/30/2020
Wage Rate per Hour: \$46.00

OFFICE OF THE COMPTROLLER, CITY OF NEW YORK
CONSTRUCTION WORKER PREVAILING WAGE SCHEDULE

Supplemental Benefit Rate per Hour: **\$32.49**
Supplemental Note: \$ 37.75 on overtime

Overtime

Time and one half the regular rate after a 7 hour day.
Time and one half the regular rate for Saturday.
Time and one half the regular rate for Sunday.

Overtime Holidays

Time and one half the regular rate for work on the following holiday(s).

New Year's Day
President's Day
Memorial Day
Independence Day
Labor Day
Columbus Day
Thanksgiving Day
Christmas Day

Paid Holidays

None

(District Council of Painters #9)

PAINTER - LINE STRIPING (ROADWAY)

Striping - Machine Operator

Effective Period: 7/1/2019 - 6/30/2020

Wage Rate per Hour: **\$35.00**

Supplemental Benefit Rate per Hour: **\$12.37**

Supplemental Note: Overtime Supplemental Benefit rate - \$8.02; New Hire Rate (0-3 months) - \$0.00

Lineperson (Thermoplastic)

Effective Period: 7/1/2019 - 6/30/2020

Wage Rate per Hour: **\$39.00**

Supplemental Benefit Rate per Hour: **\$12.37**

Supplemental Note: Overtime Supplemental Benefit rate - \$8.02; New Hire Rate (0-3 months) - \$0.00

Overtime Description

For Paid Holidays: Employees will only receive Holiday Pay for holidays not worked if said employee worked both the weekday before and the weekday after the holiday.

Overtime

Time and one half the regular rate after an 8 hour day.

OFFICE OF THE COMPTROLLER, CITY OF NEW YORK
CONSTRUCTION WORKER PREVAILING WAGE SCHEDULE

Time and one half the regular rate for Saturday.

Time and one half the regular rate for Sunday.

Time and one half the regular rate for work on the following holiday(s).

Paid Holidays

New Year's Day

Good Friday

Memorial Day

Independence Day

Labor Day

Columbus Day

Presidential Election Day

Thanksgiving Day

Day after Thanksgiving

Christmas Day

Shift Rates

Four (4), ten (10) hour days may be worked at straight time during a week, Monday thru Thursday.
Friday may be used as a make-up day.

Vacation

Employees with one to two years service shall accrue vacation based on hours worked: 250 hours worked - 1 day vacation; 500 hours worked - 2 days vacation; 750 hours worked - 3 days vacation; 900 hours worked - 4 days vacation; 1,000 hours worked - 5 days vacation. Employees with two to five years service receive two weeks vacation. Employees with five to twenty years service receive three weeks vacation. Employees with twenty to twenty-five years service receive four weeks vacation. Employees with 25 or more years service receive five weeks vacation. Vacation must be taken during winter months.

(Local #1010)

PAINTER - METAL POLISHER

METAL POLISHER

Effective Period: 7/1/2019 - 6/30/2020

Wage Rate per Hour: \$30.58

Supplemental Benefit Rate per Hour: \$7.16

METAL POLISHER - NEW CONSTRUCTION

Effective Period: 7/1/2019 - 6/30/2020

Wage Rate per Hour: \$31.53

Supplemental Benefit Rate per Hour: \$7.16

METAL POLISHER - SCAFFOLD OVER 34 FEET

Effective Period: 7/1/2019 - 6/30/2020

OFFICE OF THE COMPTROLLER, CITY OF NEW YORK
CONSTRUCTION WORKER PREVAILING WAGE SCHEDULE

Wage Rate per Hour: **\$34.08**

Supplemental Benefit Rate per Hour: **\$7.16**

Overtime Description

All work performed on Saturdays shall be paid at time-in-a half. The exception being; for suspended scaffold work and work deemed as a construction project; an eight (8) hour shift lost during the week due to circumstances beyond the control of the employer, up to a maximum of eight (8) hours per week, may be worked on Saturday at the straight time rate.

Overtime

Time and one half the regular rate after an 8 hour day.

Time and one half the regular rate for Saturday.

Double time the regular rate for Sunday.

Saturday may be used as a make-up day at straight time when a day is lost during that week to inclement weather.

Triple time the regular rate for work on the following holiday(s).

Paid Holidays

New Year's Day

Martin Luther King Jr. Day

President's Day

Memorial Day

Independence Day

Labor Day

Columbus Day

Veteran's Day

Thanksgiving Day

Day after Thanksgiving

Christmas Day

Shift Rates

Four Days a week at Ten (10) hours straight a day.

Local 8A-28A

PAINTER - SIGN

Sign Painter

Effective Period: 7/1/2019 - 6/30/2020

Wage Rate per Hour: **\$41.98**

Supplemental Benefit Rate per Hour: **\$20.10**

Assistant Sign Painter

Effective Period: 7/1/2019 - 6/30/2020

OFFICE OF THE COMPTROLLER, CITY OF NEW YORK
CONSTRUCTION WORKER PREVAILING WAGE SCHEDULE

Wage Rate per Hour: **\$35.67**

Supplemental Benefit Rate per Hour: **\$18.47**

Overtime

Time and one half the regular rate after an 8 hour day.

Time and one half the regular rate for Saturday.

Time and one half the regular rate for Sunday.

Double time the regular rate for work on the following holiday(s).

Paid Holidays

New Year's Day

President's Day

Memorial Day

Independence Day

Labor Day

Columbus Day

Election Day

Thanksgiving Day

Day after Thanksgiving

Christmas Day

Vacation

At least 1 year of employment.....1 week

2 years or more of employment.....2 weeks

8 years or more of employment.....3 weeks

(Local #8A-28A)

PAINTER - STRUCTURAL STEEL

Painters on Structural Steel

Effective Period: 7/1/2019 - 6/30/2020

Wage Rate per Hour: **\$49.50**

Supplemental Benefit Rate per Hour: **\$41.83**

Painter - Power Tool

Effective Period: 7/1/2019 - 6/30/2020

Wage Rate per Hour: **\$55.50**

Supplemental Benefit Rate per Hour: **\$41.83**

Overtime Wage Rate: \$6.00 above the "Painters on Structural Steel" overtime rate.

Overtime Description

Supplemental Benefits shall be paid for each hour worked, up to forty (40) hours per week for the period of May 1st to November 15th or up to fifty (50) hours per week for the period of November 16th to April 30th.

OFFICE OF THE COMPTROLLER, CITY OF NEW YORK
CONSTRUCTION WORKER PREVAILING WAGE SCHEDULE

Overtime

Time and one half the regular rate after a 7 hour day.
Time and one half the regular rate for Saturday.
Time and one half the regular rate for Sunday.

Overtime Holidays

Double time the regular rate for work on the following holiday(s).

New Year's Day
Memorial Day
Independence Day
Labor Day
Thanksgiving Day
Christmas Day

Paid Holidays

None

Shift Rates

Regular hourly rates plus a ten per cent (10%) differential

(Local #806)

PAPERHANGER

Paperhanger

Effective Period: 7/1/2019 - 6/30/2020

Wage Rate per Hour: **\$45.40**

Supplemental Benefit Rate per Hour: **\$34.74**

Supplemental Note: Supplemental benefits are to be paid at the appropriate straight time and overtime rate.

Overtime

Time and one half the regular rate after a 7 hour day.
Time and one half the regular rate for Saturday.
Time and one half the regular rate for Sunday.

Overtime Holidays

Time and one half the regular rate for work on the following holiday(s).

New Year's Day
President's Day
Memorial Day
Independence Day
Labor Day
Thanksgiving Day
Day after Thanksgiving
Christmas Day

OFFICE OF THE COMPTROLLER, CITY OF NEW YORK
CONSTRUCTION WORKER PREVAILING WAGE SCHEDULE

Paid Holidays

None

Shift Rates

Evening shift - 4:30 P.M. to 12:00 Midnight (regular rate of pay); any work performed before 7:00 A.M. shall be at time and one half the regular base rate of pay.

(District Council of Painters #9)

PAVER AND ROADBUILDER

Paver & Roadbuilder - Formsetter

Effective Period: 7/1/2019 - 6/30/2020

Wage Rate per Hour: \$46.85

Supplemental Benefit Rate per Hour: \$44.86

Supplemental Note: For time and one half overtime - \$48.74 For double overtime - \$52.61

Paver & Roadbuilder - Laborer

Paving and road construction work, regardless of material used, including but not limited to preparation of job sites, removal of old surfaces, asphalt and/or concrete, by whatever method, including but not limited to milling; laying of concrete; laying of asphalt for temporary, patchwork, and utility paving (but not production paving); site preparation and incidental work for installation of rubberized materials and similar surfaces; installation and repair of temporary construction fencing; slurry/seal coating, paving stones, maintenance of safety surfaces; play equipment installation, and other related work.

Effective Period: 7/1/2019 - 6/30/2020

Wage Rate per Hour: \$42.98

Supplemental Benefit Rate per Hour: \$44.86

Supplemental Note: For time and one half overtime - \$48.74 For double overtime - \$52.61

Production Paver & Roadbuilder - Screed Person

(Production paving is asphalt paving when using a paving machine or on a project where a paving machine is traditionally used)

Adjustment of paving machinery on production paving jobs.

Effective Period: 7/1/2019 - 6/30/2020

Wage Rate per Hour: \$47.45

Supplemental Benefit Rate per Hour: \$44.86

Supplemental Note: For time and one half overtime - \$48.74 For double overtime - \$52.61

Production Paver & Roadbuilder - Raker

OFFICE OF THE COMPTROLLER, CITY OF NEW YORK
CONSTRUCTION WORKER PREVAILING WAGE SCHEDULE

Effective Period: 7/1/2019 - 6/30/2020

Wage Rate per Hour: \$46.85

Supplemental Benefit Rate per Hour: \$44.86

Supplemental Note: For time and one half overtime - \$48.74 For double overtime - \$52.61

Production Paver & Roadbuilder - Shoveler

General laborer (except removal of surfaces - see Paver and Roadbuilder-Laborer) including but not limited to tamper, AC paint and liquid tar work.

Effective Period: 7/1/2019 - 6/30/2020

Wage Rate per Hour: \$42.98

Supplemental Benefit Rate per Hour: \$44.86

Supplemental Note: For time and one half overtime - \$48.74 For double overtime - \$52.61

Overtime Description

If an employee works New Year's Day or Christmas Day, they receive the single time rate plus 25%.

For Paid Holidays: Holiday pay for all holidays shall be prorated based two hours per day for each day worked in the holiday week, not to exceed 8 hours of holiday pay.

Overtime

Time and one half the regular rate after an 8 hour day.

Time and one half the regular rate for Saturday.

Double time the regular rate for Sunday.

Overtime Holidays

Double time the regular rate for work on the following holiday(s).

Memorial Day

Independence Day

Labor Day

Columbus Day

Thanksgiving Day

Paid Holidays

Memorial Day

Independence Day

Labor Day

Thanksgiving Day

Shift Rates

When two shifts are employed, the work period for each shift shall be a continuous eight (8) hours. When three shifts are employed, each shift will work seven and one half (7 ½) hours but will be paid for eight (8) hours since only one half (1/2) hour is allowed for meal time.

When two or more shifts are employed, single time will be paid for each shift.

Night Work - On night work, the first eight (8) hours of work will be paid for at the single time rate, except that production paving work shall be paid at 10% over the single time rate for the screed person, rakers and shovelers directly involved only. This differential is to be paid when there is only one shift and the shift works at night. All other workers will be exempt. Hours worked over eight (8) hours during said shift shall be paid for at the time and one-half rate.

OFFICE OF THE COMPTROLLER, CITY OF NEW YORK
CONSTRUCTION WORKER PREVAILING WAGE SCHEDULE

(Local #1010)

PLASTERER

Plasterer

Effective Period: 7/1/2019 - 6/30/2020
Wage Rate per Hour: \$45.93
Supplemental Benefit Rate per Hour: \$26.52

Overtime

Time and one half the regular rate after an 8 hour day.
Time and one half the regular rate for Saturday.
Double time the regular rate for Sunday.
Saturday may be used as a make-up day at straight time when a day is lost during that week to inclement weather.

Overtime Holidays

Double time the regular rate for work on the following holiday(s).
New Year's Day
President's Day
Memorial Day
Independence Day
Labor Day
Thanksgiving Day
Christmas Day

Paid Holidays

None

Shift Rates

When it is not possible to conduct work during regular working hours (between 6:30am and 4:30pm), a shift differential shall be paid at the regular hourly rate plus a twelve per cent (12%) per hour differential. Workers on shift work shall be allowed a paid one-half hour meal break.

(Local #262)

PLASTERER - TENDER

Plasterer - Tender

OFFICE OF THE COMPTROLLER, CITY OF NEW YORK
CONSTRUCTION WORKER PREVAILING WAGE SCHEDULE

Effective Period: 7/1/2019 - 6/30/2020

Wage Rate per Hour: \$38.40

Supplemental Benefit Rate per Hour: \$31.04

Overtime

Time and one half the regular rate after an 8 hour day.

Time and one half the regular rate for Saturday.

Double time the regular rate for Sunday.

Saturday may be used as a make-up day at straight time when a day is lost during that week to inclement weather.

Overtime Holidays

Double time the regular rate for work on the following holiday(s).

New Year's Day

Washington's Birthday

Memorial Day

Independence Day

Labor Day

Presidential Election Day

Thanksgiving Day

Christmas Day

Paid Holidays

None

Shift Rates

When work commences outside regular work hours, workers receive an hour additional (differential) wage and supplement payment. Eight hours pay for seven hours work or nine hours pay for eight hours work.

(Mason Tenders District Council)

PLUMBER

Plumber

Effective Period: 7/1/2019 - 6/30/2020

Wage Rate per Hour: \$69.00

Supplemental Benefit Rate per Hour: \$37.20

Supplemental Note: Supplemental benefit contributions are to be made at the applicable overtime rates.

Plumber - Temporary Services

Temporary Services - When there are no Plumbers on the job site, there may be three shifts designed to cover the entire twenty-four hour period, including weekends if necessary, at the following rate straight time.

OFFICE OF THE COMPTROLLER, CITY OF NEW YORK
CONSTRUCTION WORKER PREVAILING WAGE SCHEDULE

Effective Period: 7/1/2019 - 6/30/2020

Wage Rate per Hour: **\$55.28**

Supplemental Benefit Rate per Hour: **\$29.68**

Overtime Description

Double time the regular rate after a 7 hour day - unless for new construction site work where the plumbing contract price is \$1.5 million or less, the hours of labor can be 8 hours per day at the employers option. On Alteration jobs when other mechanical trades at the site are working an eighth hour at straight time, then the plumber shall also work an eighth hour at straight time.

Overtime

Double time the regular time rate for Saturday.

Double time the regular rate for Sunday.

Overtime Holidays

Double time the regular rate for work on the following holiday(s).

New Year's Day

President's Day

Memorial Day

Independence Day

Labor Day

Columbus Day

Veteran's Day

Thanksgiving Day

Day after Thanksgiving

Christmas Day

Shift Rates

Shift work, when directly specified in public agency or authority documents where plumbing contract is \$8 million or less, will be permitted. 30% shift premium shall be paid for wages and fringe benefits for 4:00 pm and midnight shifts Monday to Friday. 50% shift premium shall be paid for wages and fringe benefits for 4:00 pm and midnight shift work performed on weekends. For shift work on holidays, double time wages and fringe benefits shall be paid.

(Plumbers Local #1)

PLUMBER (MECHANICAL EQUIPMENT AND SERVICE)

(Mechanical Equipment and Service work shall include any repair and/or replacement of the present plumbing system.)

Plumber

Effective Period: 7/1/2019 - 6/30/2020

Wage Rate per Hour: **\$43.05**

Supplemental Benefit Rate per Hour: **\$17.71**

OFFICE OF THE COMPTROLLER, CITY OF NEW YORK
CONSTRUCTION WORKER PREVAILING WAGE SCHEDULE

Overtime

Time and one half the regular rate after an 8 hour day.
Time and one half the regular rate for Saturday.
Time and one half the regular rate for Sunday.

Overtime Holidays

Time and one half the regular rate for work on the following holiday(s).

New Year's Day
President's Day
Memorial Day
Independence Day
Thanksgiving Day
Day after Thanksgiving
Christmas Day

Paid Holidays

None

(Plumbers Local # 1)

**PLUMBER (RESIDENTIAL RATES FOR 1, 2 AND 3 FAMILY HOME
CONSTRUCTION)**

Effective Period: 7/1/2019 - 6/30/2020
Wage Rate per Hour: \$47.89
Supplemental Benefit Rate per Hour: \$26.74

Overtime

Double time the regular rate after an 8 hour day.
Double time the regular time rate for Saturday.
Double time the regular rate for Sunday.

Overtime Holidays

Double time the regular rate for work on the following holiday(s).

New Year's Day
President's Day
Memorial Day
Independence Day
Labor Day
Columbus Day
Veteran's Day
Thanksgiving Day
Day after Thanksgiving
Christmas Day

OFFICE OF THE COMPTROLLER, CITY OF NEW YORK
CONSTRUCTION WORKER PREVAILING WAGE SCHEDULE

Paid Holidays

None

Shift Rates

30% shift premium shall be paid for wages and fringe benefits for 4:00 pm and midnight shifts Monday to Friday.
50% shift premium shall be paid for wages and fringe benefits for 4:00 pm and midnight shift work performed on weekends. For shift work on holidays, double time wages and fringe benefits shall be paid.

(Plumbers Local #1)

PLUMBER: PUMP & TANK
Oil Trades (Installation and Maintenance)

Plumber - Pump & Tank

Effective Period: 7/1/2019 - 6/30/2020

Wage Rate per Hour: \$67.45

Supplemental Benefit Rate per Hour: \$25.26

Overtime

Time and one half the regular rate after an 8 hour day.

Time and one half the regular rate for Saturday.

Time and one half the regular rate for Sunday.

Overtime Holidays

Time and one half the regular rate for work on the following holiday(s).

New Year's Day

President's Day

Memorial Day

Independence Day

Labor Day

Columbus Day

Veteran's Day

Thanksgiving Day

Day after Thanksgiving

Christmas Day

Paid Holidays

None

Shift Rates

All work outside the regular workday (8:00 A.M. to 3:30 P.M.) is to be paid at time and one half the regular hourly rate

OFFICE OF THE COMPTROLLER, CITY OF NEW YORK
CONSTRUCTION WORKER PREVAILING WAGE SCHEDULE

(Plumbers Local #1)

**POINTER, WATERPROOFER, CAULKER, SANDBLASTER,
STEAMBLASTER**
(Exterior Building Renovation)

Journey person

Effective Period: 7/1/2019 - 6/30/2020
Wage Rate per Hour: \$53.42
Supplemental Benefit Rate per Hour: \$26.52

Overtime

Time and one half the regular rate after an 8 hour day.
Time and one half the regular rate for Saturday.
Time and one half the regular rate for Sunday.
Saturday may be used as a make-up day at straight time when a day is lost during that week to inclement weather.

Overtime Holidays

Time and one half the regular rate for work on the following holiday(s).

New Year's Day
Martin Luther King Jr. Day
President's Day
Memorial Day
Independence Day
Labor Day
Thanksgiving Day
Christmas Day

Paid Holidays

None

Shift Rates

All work outside the regular work day (an eight hour workday between the hours of 6:00 A.M. and 4:30 P.M.) is to be paid at time and one half the regular rate.

(Bricklayer District Council)

ROOFER

OFFICE OF THE COMPTROLLER, CITY OF NEW YORK
CONSTRUCTION WORKER PREVAILING WAGE SCHEDULE

Roofer

Effective Period: 7/1/2019 - 6/30/2020

Wage Rate per Hour: **\$43.50**

Supplemental Benefit Rate per Hour: **\$33.81**

Overtime

Time and one half the regular rate after an 8 hour day.

Time and one half the regular rate for Saturday.

Time and one half the regular rate for Sunday.

Overtime Holidays

Time and one half the regular rate for work on the following holiday(s).

New Year's Day

Memorial Day

Independence Day

Labor Day

Thanksgiving Day

Christmas Day

Paid Holidays

None

Shift Rates

Second shift - Regular hourly rate plus a 10% differential. Third shift - Regular hourly rate plus a 15% differential.

(Local #8)

SHEET METAL WORKER

Sheet Metal Worker

Effective Period: 7/1/2019 - 6/30/2020

Wage Rate per Hour: **\$50.15**

Supplemental Benefit Rate per Hour: **\$50.55**

Supplemental Note: Supplemental benefit contributions are to be made at the applicable overtime rates.

Sheet Metal Worker - Fan Maintenance

(The temporary operation of fans or blowers in new or existing buildings for heating and/or ventilation, and/or air conditioning prior to the completion of the project.)

Effective Period: 7/1/2019 - 6/30/2020

Wage Rate per Hour: **\$40.12**

Supplemental Benefit Rate per Hour: **\$50.55**

OFFICE OF THE COMPTROLLER, CITY OF NEW YORK
CONSTRUCTION WORKER PREVAILING WAGE SCHEDULE

Sheet Metal Worker - Duct Cleaner

Effective Period: 7/1/2019 - 6/30/2020

Wage Rate per Hour: \$16.08

Supplemental Benefit Rate per Hour: \$11.63

Overtime

Time and one half the regular rate after an 8 hour day.

Time and one half the regular rate for Saturday.

Double time the regular rate for Sunday.

Overtime Holidays

Double time the regular rate for work on the following holiday(s).

New Year's Day

Martin Luther King Jr. Day

President's Day

Memorial Day

Independence Day

Labor Day

Columbus Day

Veteran's Day

Thanksgiving Day

Day after Thanksgiving

Christmas Day

Paid Holidays

None

Shift Rates

Work that can only be performed outside regular working hours (eight hours of work between 7:30 A.M. and 3:30 P.M.) - First shift (work between 3:30 P.M. and 11:30 P.M.) - 10% differential above the established hourly rate.
Second shift (work between 11:30 P.M. and 7:30 A.M.) - 15% differential above the established hourly rate.

For Fan Maintenance: On all full shifts of fan maintenance work the straight time hourly rate of pay will be paid for each shift, including nights, Saturdays, Sundays, and holidays.

(Local #28)

**SHEET METAL WORKER - SPECIALTY
(Decking & Siding)**

Sheet Metal Specialty Worker

OFFICE OF THE COMPTROLLER, CITY OF NEW YORK
CONSTRUCTION WORKER PREVAILING WAGE SCHEDULE

The first worker to perform this work must be paid at the rate of the Sheet Metal Worker. The second and third workers shall be paid the Specialty Worker Rate. The ratio of One Sheet Metal Worker, then Two Specialty Workers shall be utilized thereafter.

Effective Period: 7/1/2019 - 6/30/2020

Wage Rate per Hour: \$46.30

Supplemental Benefit Rate per Hour: \$25.95

Supplemental Note: Supplemental benefit contributions are to be made at the applicable overtime rates.

Overtime

Time and one half the regular rate after an 8 hour day.

Time and one half the regular rate for Saturday.

Double time the regular rate for Sunday.

Overtime Holidays

Double time the regular rate for work on the following holiday(s).

New Year's Day

Martin Luther King Jr. Day

President's Day

Memorial Day

Independence Day

Labor Day

Columbus Day

Veteran's Day

Thanksgiving Day

Christmas Day

Paid Holidays

None

(Local #28)

SHIPYARD WORKER

Shipyard Mechanic - First Class

Effective Period: 7/1/2019 - 6/30/2020

Wage Rate per Hour: \$28.50

Supplemental Benefit Rate per Hour: \$3.95

Shipyard Mechanic - Second Class

Effective Period: 7/1/2019 - 6/30/2020

Wage Rate per Hour: \$19.07

Supplemental Benefit Rate per Hour: \$3.59

OFFICE OF THE COMPTROLLER, CITY OF NEW YORK
CONSTRUCTION WORKER PREVAILING WAGE SCHEDULE

Shipyard Laborer - First Class

Effective Period: 7/1/2019 - 6/30/2020
Wage Rate per Hour: \$23.40
Supplemental Benefit Rate per Hour: \$3.75

Shipyard Laborer - Second Class

Effective Period: 7/1/2019 - 6/30/2020
Wage Rate per Hour: \$17.38
Supplemental Benefit Rate per Hour: \$3.52

Shipyard Dockhand - First Class

Effective Period: 7/1/2019 - 6/30/2020
Wage Rate per Hour: \$21.57
Supplemental Benefit Rate per Hour: \$3.68

Shipyard Dockhand - Second Class

Effective Period: 7/1/2019 - 6/30/2020
Wage Rate per Hour: \$17.28
Supplemental Benefit Rate per Hour: \$3.52

Overtime Description

Work performed on holiday is paid double time the regular hourly wage rate plus holiday pay.

Overtime

Time and one half the regular rate after an 8 hour day.
Time and one half the regular rate for Saturday.
Double time the regular rate for Sunday.
Time and one half the regular hourly rate after 40 hours in any work week.

Paid Holidays

New Year's Day
Martin Luther King Jr. Day
President's Day
Good Friday
Memorial Day
Independence Day
Labor Day
Thanksgiving Day
Day after Thanksgiving
Christmas Day

Based on Survey Data

OFFICE OF THE COMPTROLLER, CITY OF NEW YORK
CONSTRUCTION WORKER PREVAILING WAGE SCHEDULE

SIGN ERECTOR
(Sheet Metal, Plastic, Electric, and Neon)

Sign Erector

Effective Period: 7/1/2019 - 6/30/2020
Wage Rate per Hour: \$49.35
Supplemental Benefit Rate per Hour: \$54.63

Overtime

Time and one half the regular rate after a 7 hour day.
Time and one half the regular rate for Saturday.
Time and one half the regular rate for Sunday.
Time and one half the regular rate for work on the following holiday(s).

Paid Holidays

New Year's Day
President's Day
Memorial Day
Independence Day
Labor Day
Columbus Day
Election Day
Thanksgiving Day
Day after Thanksgiving
Christmas Day

Shift Rates

Time and one half the regular hourly rate is to be paid for all hours worked outside the regular workday either (7:00 A.M. through 2:30 P.M.) or (8:00 A.M. through 3:30 P.M.)

(Local #137)

STEAMFITTER

Steamfitter I

Effective Period: 7/1/2019 - 6/30/2020
Wage Rate per Hour: \$57.50
Supplemental Benefit Rate per Hour: \$57.29
Supplemental Note: Overtime supplemental benefit rate: \$113.84

Steamfitter -Temporary Services

OFFICE OF THE COMPTROLLER, CITY OF NEW YORK
CONSTRUCTION WORKER PREVAILING WAGE SCHEDULE

The steamfitters shall not do any other work and shall not be permitted to work more than one shift in a twenty-four hour day. When steamfitters are present during the regular working day, no temporary services steamfitter will be required

Effective Period: 7/1/2019 - 6/30/2020

Wage Rate per Hour: \$43.70

Supplemental Benefit Rate per Hour: \$46.54

Overtime

Double time the regular rate after a 7 hour day.

Double time the regular time rate for Saturday.

Double time the regular rate for Sunday.

Overtime Holidays

Double time the regular rate for work on the following holiday(s).

New Year's Day

President's Day

Memorial Day

Independence Day

Labor Day

Columbus Day

Veteran's Day

Thanksgiving Day

Day after Thanksgiving

Christmas Day

Paid Holidays

None

Shift Rates

Work performed between 3:30 P.M. and 7:00 A.M. and on Saturdays, Sundays and Holidays shall be at double time the regular hourly rate and paid at the overtime supplemental benefit rate above.

Steamfitter II

For heating, ventilation, air conditioning and mechanical public work contracts with a dollar value not to exceed \$30,000,000 and for fire protection/sprinkler public work contracts not to exceed \$3,000,000.

Effective Period: 7/1/2019 - 6/30/2020

Wage Rate per Hour: \$57.50

Supplemental Benefit Rate per Hour: \$57.29

Supplemental Note: Overtime supplemental benefit rate: \$113.84

Steamfitter -Temporary Services

OFFICE OF THE COMPTROLLER, CITY OF NEW YORK
CONSTRUCTION WORKER PREVAILING WAGE SCHEDULE

The steamfitters shall not do any other work and shall not be permitted to work more than one shift in a twenty-four hour day. When steamfitters are present during the regular working day, no temporary services steamfitter will be required.

Effective Period: 7/1/2019 - 6/30/2020

Wage Rate per Hour: \$43.70

Supplemental Benefit Rate per Hour: \$46.54

Overtime

Double time the regular rate after an 8 hour day.

Double time the regular time rate for Saturday.

Double time the regular rate for Sunday.

Overtime Holidays

Double time the regular rate for work on the following holiday(s).

New Year's Day

President's Day

Memorial Day

Independence Day

Labor Day

Columbus Day

Veteran's Day

Thanksgiving Day

Day after Thanksgiving

Christmas Day

Paid Holidays

None

Shift Rates

May be performed outside of the regular workday except Saturday, Sunday and Holidays. A shift shall consist of eight working hours. All work performed in excess of eight hours shall be paid at double time. No shift shall commence after 7:00 P.M. on Friday or 7:00 P.M. the day before holidays. All work performed after 12:01 A.M. Saturday or 12:01 A.M. the day before a Holiday will be paid at double time. When shift work is performed the wage rate for regular time worked is a 15% percent premium on wage and 15% percent premium on supplemental benefits.

On Transit Authority projects, where work is performed in the vicinity of tracks all shift work on weekends and holidays may be performed at the regular shift rates.

Local #638

STEAMFITTER - REFRIGERATION AND AIR CONDITIONER (Maintenance and Installation Service Person)

Refrigeration and Air Conditioner Mechanic

OFFICE OF THE COMPTROLLER, CITY OF NEW YORK
CONSTRUCTION WORKER PREVAILING WAGE SCHEDULE

Effective Period: 7/1/2019 - 6/30/2020
Wage Rate per Hour: \$42.35
Supplemental Benefit Rate per Hour: \$17.46

Refrigeration and Air Conditioner Service Person V

Effective Period: 7/1/2019 - 6/30/2020
Wage Rate per Hour: \$34.80
Supplemental Benefit Rate per Hour: \$15.59

Refrigeration and Air Conditioner Service Person IV

Effective Period: 7/1/2019 - 6/30/2020
Wage Rate per Hour: \$28.83
Supplemental Benefit Rate per Hour: \$14.05

Refrigeration and Air Conditioner Service Person III

Filter changing and maintenance thereof, oil and greasing, tower and coil cleaning, scraping and painting, general housekeeping, taking of water samples.

Effective Period: 7/1/2019 - 6/30/2020
Wage Rate per Hour: \$24.74
Supplemental Benefit Rate per Hour: \$12.91

Refrigeration and Air Conditioner Service Person II

Filter changing and maintenance thereof, oil and greasing, tower and coil cleaning, scraping and painting, general housekeeping, taking of water samples.

Effective Period: 7/1/2019 - 6/30/2020
Wage Rate per Hour: \$20.51
Supplemental Benefit Rate per Hour: \$11.83

Refrigeration and Air Conditioner Service Person I

Filter changing and maintenance thereof, oil and greasing, tower and coil cleaning, scraping and painting, general housekeeping, taking of water samples.

Effective Period: 7/1/2019 - 6/30/2020
Wage Rate per Hour: \$15.01
Supplemental Benefit Rate per Hour: \$10.60

Overtime

Time and one half the regular rate after an 8 hour day.
Time and one half the regular rate for Saturday.
Double time the regular rate for Sunday.

OFFICE OF THE COMPTROLLER, CITY OF NEW YORK
CONSTRUCTION WORKER PREVAILING WAGE SCHEDULE

Overtime Holidays

Double time the regular rate for work on the following holiday(s).

New Year's Day
Independence Day
Labor Day
Veteran's Day
Thanksgiving Day
Christmas Day

Double time and one half the regular rate for work on the following holiday(s).

Martin Luther King Jr. Day
President's Day
Memorial Day
Columbus Day

Paid Holidays

New Year's Day
Martin Luther King Jr. Day
President's Day
Memorial Day
Independence Day
Labor Day
Columbus Day
Veteran's Day
Thanksgiving Day
Christmas Day

(Local #638B)

STONE MASON - SETTER

Stone Mason - Setter

(Assisted by Derrickperson and Rigger)

Effective Period: 7/1/2019 - 6/30/2020

Wage Rate per Hour: \$54.17

Supplemental Benefit Rate per Hour: \$42.65

Overtime

Time and one half the regular rate after a 7 hour day.

Time and one half the regular rate for Saturday.

Double time the regular rate for Sunday.

Overtime Holidays

Double time the regular rate for work on the following holiday(s).

New Year's Day

OFFICE OF THE COMPTROLLER, CITY OF NEW YORK
CONSTRUCTION WORKER PREVAILING WAGE SCHEDULE

Washington's Birthday
Good Friday
Memorial Day
Independence Day
Labor Day
Thanksgiving Day
Christmas Day

Paid Holidays

1/2 day on Christmas Eve if work is performed in the A.M.

Shift Rates

For all work outside the regular workday (8:00 A.M. to 3:30 P.M. Monday through Friday), the pay shall be straight time plus a ten percent (10%) differential.

(Bricklayers District Council)

TAPER

Drywall Taper

Effective Period: 7/1/2019 - 6/30/2020
Wage Rate per Hour: \$47.82
Supplemental Benefit Rate per Hour: \$26.81

Overtime

Time and one half the regular rate after a 7 hour day.
Time and one half the regular rate for Saturday.
Time and one half the regular rate for Sunday.

Overtime Holidays

Time and one half the regular rate for work on the following holiday(s).

New Year's Day
Martin Luther King Jr. Day
President's Day
Good Friday
Memorial Day
Independence Day
Labor Day
Columbus Day
Thanksgiving Day
Christmas Day

Paid Holidays

Any worker who reports to work on Christmas Eve or New Year's Eve pursuant to his employer's instruction shall be entitled to three (3) hours afternoon pay without working.

OFFICE OF THE COMPTROLLER, CITY OF NEW YORK
CONSTRUCTION WORKER PREVAILING WAGE SCHEDULE

(Local #1974)

TELECOMMUNICATION WORKER

(Install/maintain/repair telecommunications cables carrying data, video, and/or voice except for installation on building construction/alteration/renovation projects.)

Telecommunication Worker

Effective Period: 7/1/2019 - 6/30/2020

Wage Rate per Hour: **\$44.75**

Supplemental Benefit Rate per Hour: **\$23.15**

Supplemental Note: The above rate applies for Manhattan, Bronx, Brooklyn, Queens. \$22.84 for Staten Island only.

Overtime

Time and one half the regular rate after an 8 hour day.

Time and one half the regular rate for Saturday.

Time and one half the regular rate for Sunday.

Overtime Holidays

Time and one half the regular rate for work on the following holiday(s).

New Year's Day
Lincoln's Birthday
Washington's Birthday
Memorial Day
Independence Day
Labor Day
Columbus Day
Election Day
Veteran's Day
Thanksgiving Day
Christmas Day

Paid Holidays

New Year's Day
Lincoln's Birthday
Washington's Birthday
Memorial Day
Independence Day
Labor Day
Columbus Day
Election Day
Veteran's Day
Thanksgiving Day
Christmas Day

OFFICE OF THE COMPTROLLER, CITY OF NEW YORK
CONSTRUCTION WORKER PREVAILING WAGE SCHEDULE

Employees have the option of observing either Martin Luther King's Birthday or the day after Thanksgiving instead of Lincoln's Birthday

Shift Rates

For any workday that starts before 8A.M. or ends after 6P.M. there is a 10% differential for the applicable worker's hourly rate.

Vacation

After 6 months.....one week.
After 12 months but less than 7 years.....two weeks.
After 7 or more but less than 15 years.....three weeks.
After 15 years or more but less than 25 years.....four weeks.

(C.W.A.)

TILE FINISHER

Tile Finisher

Effective Period: 7/1/2019 - 6/30/2020
Wage Rate per Hour: **\$42.72**
Supplemental Benefit Rate per Hour: **\$33.57**

Overtime

Time and one half the regular rate after a 7 hour day.
Time and one half the regular rate for Saturday.
Double time the regular rate for Sunday.

Overtime Holidays

Double time the regular rate for work on the following holiday(s).
New Year's Day
President's Day
Good Friday
Memorial Day
Independence Day
Labor Day
Columbus Day
Veteran's Day
Thanksgiving Day
Day after Thanksgiving
Christmas Day

Paid Holidays

None

Shift Rates

OFFICE OF THE COMPTROLLER, CITY OF NEW YORK
CONSTRUCTION WORKER PREVAILING WAGE SCHEDULE

Off shift work day (work performed outside the regular 8:00 A.M. to 3:30 P.M. workday): shift differential of one and one quarter (1¼) times the regular straight time rate of pay for the seven hours of actual off-shift work.

(Local #7)

TILE LAYER - SETTER

Tile Layer - Setter

Effective Period: 7/1/2019 - 6/30/2020
Wage Rate per Hour: \$54.84
Supplemental Benefit Rate per Hour: \$38.32

Overtime

Time and one half the regular rate after a 7 hour day.
Time and one half the regular rate for Saturday.
Double time the regular rate for Sunday.

Overtime Holidays

Double time the regular rate for work on the following holiday(s).
New Year's Day
President's Day
Good Friday
Memorial Day
Independence Day
Labor Day
Columbus Day
Veteran's Day
Thanksgiving Day
Day after Thanksgiving
Christmas Day

Shift Rates

Off shift work day (work performed outside the regular 8:00 A.M. to 3:30 P.M. workday): shift differential of one and one quarter (1¼) times the regular straight time rate of pay for the seven hours of actual off-shift work.

(Local #7)

TIMBERPERSON

Timberperson

OFFICE OF THE COMPTROLLER, CITY OF NEW YORK
CONSTRUCTION WORKER PREVAILING WAGE SCHEDULE

Effective Period: 7/1/2019 - 6/30/2020

Wage Rate per Hour: \$50.05

Supplemental Benefit Rate per Hour: \$51.03

Overtime

Time and one half the regular rate after an 8 hour day.

Time and one half the regular rate for Saturday.

Double time the regular rate for Sunday.

Saturday may be used as a make-up day at straight time when a day is lost during that week to inclement weather.

Time and one half the regular hourly rate after 40 hours in any work week.

Overtime Holidays

Double time the regular rate for work on the following holiday(s).

New Year's Day

President's Day

Memorial Day

Independence Day

Labor Day

Columbus Day

Presidential Election Day

Thanksgiving Day

Christmas Day

Paid Holidays

None

Shift Rates

Off shift work commencing between 5:00 P.M. and 11:00 P.M. shall work eight and one half hours allowing for one half hour for lunch. The wage rate shall be 113% of the straight time hourly wage rate.

(Local #1536)

TUNNEL WORKER

Blasters, Mucking Machine Operators (Compressed Air Rates)

Effective Period: 7/1/2019 - 6/30/2020

Wage Rate per Hour: \$65.42

Supplemental Benefit Rate per Hour: \$56.42

Tunnel Workers (Compressed Air Rates)

Includes shield driven liner plate portions or solidification portions work (8 hour shift) during excavation phase.

Effective Period: 7/1/2019 - 6/30/2020

OFFICE OF THE COMPTROLLER, CITY OF NEW YORK
CONSTRUCTION WORKER PREVAILING WAGE SCHEDULE

Wage Rate per Hour: \$63.21
Supplemental Benefit Rate per Hour: \$54.60

Top Nipper (Compressed Air Rates)

Effective Period: 7/1/2019 - 6/30/2020
Wage Rate per Hour: \$62.02
Supplemental Benefit Rate per Hour: \$53.57

Outside Lock Tender, Outside Gauge Tender, Muck Lock Tender (Compressed Air Rates)

Effective Period: 7/1/2019 - 6/30/2020
Wage Rate per Hour: \$60.84
Supplemental Benefit Rate per Hour: \$52.63

Bottom Bell & Top Bell Signal Person: Shaft Person (Compressed Air Rates)

Effective Period: 7/1/2019 - 6/30/2020
Wage Rate per Hour: \$60.84
Supplemental Benefit Rate per Hour: \$52.63

Changehouse Attendant: Powder Watchperson (Compressed Air Rates)

Effective Period: 7/1/2019 - 6/30/2020
Wage Rate per Hour: \$53.40
Supplemental Benefit Rate per Hour: \$49.60

Blasters (Free Air Rates)

Effective Period: 7/1/2019 - 6/30/2020
Wage Rate per Hour: \$62.41
Supplemental Benefit Rate per Hour: \$54.17

Tunnel Workers (Free Air Rates)

Effective Period: 7/1/2019 - 6/30/2020
Wage Rate per Hour: \$59.72
Supplemental Benefit Rate per Hour: \$51.89

All Others (Free Air Rates)

Effective Period: 7/1/2019 - 6/30/2020
Wage Rate per Hour: \$55.18
Supplemental Benefit Rate per Hour: \$48.03

Microtunneling (Free Air Rates)

OFFICE OF THE COMPTROLLER, CITY OF NEW YORK
CONSTRUCTION WORKER PREVAILING WAGE SCHEDULE

Effective Period: 7/1/2019 - 6/30/2020
Wage Rate per Hour: \$47.78
Supplemental Benefit Rate per Hour: \$41.51

Overtime Description

For work performed during excavation and primary concrete tunnel lining phases - Double time the regular rate after an 8 hour day and Saturday, Sunday and on the following holiday(s) listed below.
For Repair-Maintenance Work on Existing Equipment and Facilities - Time and one half the regular rate after a 7 hour day, Saturday, Sunday and double time the regular rate for work on the following holiday(s) listed below.
For Small-Bore Micro Tunneling Machines - Time and one-half the regular rate shall be paid for all overtime.
For work not listed above - Time and one half the regular rate after an 8 hour day and Saturday and double time the regular rate on Sunday and on the following holiday(s) listed below.

Paid Holidays

New Year's Day
Lincoln's Birthday
President's Day
Memorial Day
Independence Day
Labor Day
Columbus Day
Election Day
Veteran's Day
Thanksgiving Day
Christmas Day

(Local #147)

UTILITY LOCATOR

(Locate & mark underground utilities for street excavation.)

Utility Locator (Year 7 and above)

Effective Period: 7/1/2019 - 6/30/2020
Wage Rate per Hour: \$31.56
Supplemental Benefit Rate per Hour: \$1.93

Utility Locator (Year 5 - 6)

Effective Period: 7/1/2019 - 6/30/2020
Wage Rate per Hour: \$22.85
Supplemental Benefit Rate per Hour: \$1.93

Utility Locator (Year 4)

OFFICE OF THE COMPTROLLER, CITY OF NEW YORK
CONSTRUCTION WORKER PREVAILING WAGE SCHEDULE

Effective Period: 7/1/2019 - 6/30/2020
Wage Rate per Hour: **\$21.54**
Supplemental Benefit Rate per Hour: \$1.93

Utility Locator (Year 3)

Effective Period: 7/1/2019 - 6/30/2020
Wage Rate per Hour: **\$20.30**
Supplemental Benefit Rate per Hour: \$1.93

Utility Locator (Year 2)

Effective Period: 7/1/2019 - 6/30/2020
Wage Rate per Hour: **\$19.13**
Supplemental Benefit Rate per Hour: \$1.93

Utility Locator (Year 1)

Effective Period: 7/1/2019 - 6/30/2020
Wage Rate per Hour: **\$18.04**
Supplemental Benefit Rate per Hour: \$1.93

Utility Locator (Up to 1 year)

Effective Period: 7/1/2019 - 6/30/2020
Wage Rate per Hour: **\$17.00**
Supplemental Benefit Rate per Hour: \$1.93
Supplemental Note: No benefits for the first 90 days of employment.

Overtime

Time and one half the regular rate for work on the following Paid Holiday(s).
Time and one half the regular hourly rate after 40 hours in any work week.

Paid Holidays

New Year's Day
Memorial Day
Independence Day
Thanksgiving Day
Christmas Day

Shift Rates

10% shift differential to employees working any shift starting between noon and 5 AM.

Vacation

For up to 1 year 0 hours
For year 1 - 2 48 hours per year
For year 3 - 9 96 hours per year
For year 10 or more 144 hours per year

OFFICE OF THE COMPTROLLER, CITY OF NEW YORK
CONSTRUCTION WORKER PREVAILING WAGE SCHEDULE

Sick Days:

For up to 1 year employee receives 40 hours paid sick leave.

For year 1 employee earns 2 hours of paid sick leave for every 100 overtime hours worked.

For year 2 - 9 years employee earns 4 hours of paid sick leave for every 100 overtime hours worked.

For year 10 or more employee earns 6 hours of paid sick leave for every 100 overtime hours worked.

(C.W.A.)

WELDER

**TO BE PAID AT THE RATE OF THE JOURNEYPERSON IN THE TRADE
PERFORMING THE WORK.**

**OFFICE OF THE COMPTROLLER, CITY OF NEW YORK
CONSTRUCTION APPRENTICE PREVAILING WAGE SCHEDULE**

OFFICE OF THE COMPTROLLER

CITY OF NEW YORK

**CONSTRUCTION APPRENTICE
PREVAILING WAGE SCHEDULE**

Pursuant to Labor Law § 220 (3-e), only apprentices who are individually registered in a bona fide program to which the employer contractor is a participant and registered with the New York State Department of Labor, may be paid at the apprentice rates in this schedule. Apprentices who are not so registered must be paid as journey persons in accordance with the trade classification of the work they actually performed.

Apprentice ratios are established to ensure the proper safety, training and supervision of apprentices. A ratio establishes the number of journey workers required for each apprentice in a program and on a job site. Ratios are interpreted as follows: in the case of a 1:1, 1:4 ratio, there must be one journey worker for the first apprentice, and four additional journey workers for each subsequent apprentice.

OFFICE OF THE COMPTROLLER, CITY OF NEW YORK
 CONSTRUCTION APPRENTICE PREVAILING WAGE SCHEDULE

TABLE OF CONTENTS

<u>CLASSIFICATION</u>	<u>PAGE</u>
BOILERMAKER.....	3
BRICKLAYER.....	4
CARPENTER.....	5
CARPENTER - HIGH RISE CONCRETE FORMS	5
CEMENT MASON.....	6
CEMENT AND CONCRETE WORKER.....	7
DERRICKPERSON & RIGGER (STONE).....	7
DOCKBUILDER/PILE DRIVER.....	8
ELECTRICIAN	9
ELEVATOR CONSTRUCTOR	11
ELEVATOR REPAIR & MAINTENANCE.....	12
ENGINEER	13
ENGINEER - OPERATING	13
FLOOR COVERER	14
GLAZIER	15
HAZARDOUS MATERIAL HANDLER.....	15
HEAT & FROST INSULATOR	16
HOUSE WRECKER	16
IRON WORKER - ORNAMENTAL.....	17
IRON WORKER - STRUCTURAL.....	18
LABORER (FOUNDATION, CONCRETE, EXCAVATING, STREET PIPE LAYER & COMMON).....	19
MARBLE MECHANICS	19
MASON TENDER	21
METALLIC LATHER.....	22
MILLWRIGHT	22
PAINTER	23
PAINTER - METAL POLISHER.....	24
PAINTER - STRUCTURAL STEEL.....	25
PAVER AND ROADBUILDER	25
PLASTERER	26
PLASTERER - TENDER.....	26
PLUMBER	27
POINTER, WATERPROOFER, CAULKER, SANDBLASTER, STEAMBLASTER.....	28
ROOFER.....	29
SHEET METAL WORKER.....	30
SIGN ERECTOR.....	31
STEAMFITTER	32
STONE MASON - SETTER.....	33
TAPER.....	34
TILE LAYER - SETTER	34
TIMBERPERSON	35

OFFICE OF THE COMPTROLLER, CITY OF NEW YORK
CONSTRUCTION APPRENTICE PREVAILING WAGE SCHEDULE

BOILERMAKER

(Ratio of Apprentice to Journeyman: 1 to 1, 1 to 3)

Boilermaker (First Year)

Effective Period: 7/1/2019 - 6/30/2020
Wage Rate Per Hour: 65% of Journeyman's rate
Supplemental Benefit Rate Per Hour: \$31.76

Boilermaker (Second Year: 1st Six Months)

Effective Period: 7/1/2019 - 6/30/2020
Wage Rate Per Hour: 70% of Journeyman's rate
Supplemental Benefit Rate Per Hour: \$33.59

Boilermaker (Second Year: 2nd Six Months)

Effective Period: 7/1/2019 - 6/30/2020
Wage Rate Per Hour: 75% of Journeyman's rate
Supplemental Benefit Rate Per Hour: \$35.43

Boilermaker (Third Year: 1st Six Months)

Effective Period: 7/1/2019 - 6/30/2020
Wage Rate Per Hour: 80% of Journeyman's rate
Supplemental Benefit Rate Per Hour: \$37.25

Boilermaker (Third Year: 2nd Six Months)

Effective Period: 7/1/2019 - 6/30/2020
Wage Rate Per Hour: 85% of Journeyman's rate
Supplemental Benefit Rate Per Hour: \$39.08

Boilermaker (Fourth Year: 1st Six Months)

Effective Period: 7/1/2019 - 6/30/2020
Wage Rate Per Hour: 90% of Journeyman's rate
Supplemental Benefit Rate Per Hour: \$40.93

Boilermaker (Fourth Year: 2nd Six Months)

Effective Period: 7/1/2019 - 6/30/2020
Wage Rate Per Hour: 95% of Journeyman's rate
Supplemental Benefit Rate Per Hour: \$42.75

(Local #5)

OFFICE OF THE COMPTROLLER, CITY OF NEW YORK
CONSTRUCTION APPRENTICE PREVAILING WAGE SCHEDULE

BRICKLAYER

(Ratio of Apprentice to Journeyman: 1 to 1, 1 to 4)

Bricklayer (First 750 Hours)

Effective Period: 7/1/2019 - 6/30/2020
Wage Rate Per Hour: 50% of Journeyman's rate
Supplemental Benefit Rate Per Hour: \$20.61

Bricklayer (Second 750 Hours)

Effective Period: 7/1/2019 - 6/30/2020
Wage Rate Per Hour: 60% of Journeyman's rate
Supplemental Benefit Rate Per Hour: \$20.61

Bricklayer (Third 750 Hours)

Effective Period: 7/1/2019 - 6/30/2020
Wage Rate Per Hour: 70% of Journeyman's rate
Supplemental Benefit Rate Per Hour: \$20.61

Bricklayer (Fourth 750 Hours)

Effective Period: 7/1/2019 - 6/30/2020
Wage Rate Per Hour: 80% of Journeyman's rate
Supplemental Benefit Rate Per Hour: \$20.61

Bricklayer (Fifth 750 Hours)

Effective Period: 7/1/2019 - 6/30/2020
Wage Rate Per Hour: 90% of Journeyman's rate
Supplemental Benefit Rate Per Hour: \$20.61

Bricklayer (Sixth 750 Hours)

Effective Period: 7/1/2019 - 6/30/2020
Wage Rate Per Hour: 95% of Journeyman's rate
Supplemental Benefit Rate Per Hour: \$20.61

(Bricklayer District Council)

OFFICE OF THE COMPTROLLER, CITY OF NEW YORK
CONSTRUCTION APPRENTICE PREVAILING WAGE SCHEDULE

CARPENTER

(Ratio of Apprentice to Journeyman: 1 to 1, 1 to 4)

Carpenter (First Year)

Effective Period: 7/1/2019 - 6/30/2020
Wage Rate Per Hour: 40% of Journeyman's rate
Supplemental Benefit Rate Per Hour For Building Apprentice: \$31.44
Supplemental Benefit Rate Per Hour For Heavy Apprentice: \$33.49

Carpenter (Second Year)

Effective Period: 7/1/2019 - 6/30/2020
Wage Rate Per Hour: 50% of Journeyman's rate
Supplemental Benefit Rate Per Hour For Building Apprentice: \$31.44
Supplemental Benefit Rate Per Hour For Heavy Apprentice: \$33.49

Carpenter (Third Year)

Effective Period: 7/1/2019 - 6/30/2020
Wage Rate Per Hour: 65% of Journeyman's rate
Supplemental Benefit Rate Per Hour For Building Apprentice: \$31.44
Supplemental Benefit Rate Per Hour For Heavy Apprentice: \$33.49

Carpenter (Fourth Year)

Effective Period: 7/1/2019 - 6/30/2020
Wage Rate Per Hour: 80% of Journeyman's rate
Supplemental Benefit Rate Per Hour For Building Apprentice: \$31.44
Supplemental Benefit Rate Per Hour For Heavy Apprentice: \$33.49

(Carpenters District Council)

CARPENTER - HIGH RISE CONCRETE FORMS

(Ratio of Apprentice to Journeyman: 1 to 1, 2 to 5)

Carpenter - High Rise (First Year)

Effective Period: 7/1/2019 - 6/30/2020
Wage Rate per Hour: \$17.52
Supplemental Benefit Rate per Hour: \$16.30

Carpenter - High Rise (Second Year)

OFFICE OF THE COMPTROLLER, CITY OF NEW YORK
CONSTRUCTION APPRENTICE PREVAILING WAGE SCHEDULE

Effective Period: 7/1/2019 - 6/30/2020
Wage Rate per Hour: \$23.95
Supplemental Benefit Rate per Hour: \$16.43

Carpenter - High Rise (Third Year)

Effective Period: 7/1/2019 - 6/30/2020
Wage Rate per Hour: \$30.53
Supplemental Benefit Rate per Hour: \$16.56

Carpenter - High Rise (Fourth Year)

Effective Period: 7/1/2019 - 6/30/2020
Wage Rate per Hour: \$38.15
Supplemental Benefit Rate per Hour: \$16.71

(Carpenters District Council)

CEMENT MASON

(Ratio of Apprentice to Journeyman: 1 to 1, 1 to 4)

Cement Mason (First Year)

Effective Period: 7/1/2019 - 6/30/2020
Wage and Supplemental Rate Per Hour: 50% of Journeyman's Rate

Cement Mason (Second Year)

Effective Period: 7/1/2019 - 6/30/2020
Wage and Supplemental Rate Per Hour: 60% of Journeyman's Rate

Cement Mason (Third Year)

Effective Period: 7/1/2019 - 6/30/2020
Wage and Supplemental Rate Per Hour: 70% of Journeyman's Rate

(Local #780)

OFFICE OF THE COMPTROLLER, CITY OF NEW YORK
CONSTRUCTION APPRENTICE PREVAILING WAGE SCHEDULE

CEMENT AND CONCRETE WORKER

(Ratio of Apprentice to Journeyman: 1 to 1, 1 to 3)

Cement & Concrete Worker (First 1333 hours)

Effective Period: 7/1/2019 - 6/30/2020
Wage Rate Per Hour: 50% of Journeyman's rate
Supplemental Benefit Rate Per Hour: \$20.00

Cement & Concrete Worker (Second 1333 hours)

Effective Period: 7/1/2019 - 6/30/2020
Wage Rate Per Hour: 65% of Journeyman's rate
Supplemental Benefit Rate Per Hour: \$25.45

Cement & Concrete Worker (Last 1334 hours)

Effective Period: 7/1/2019 - 6/30/2020
Wage Rate Per Hour: 80% of Journeyman's rate
Supplemental Benefit Rate Per Hour: \$26.95

Cement & Concrete Worker (Hired after 2/6/2016 - First 1334 hours)

Effective Period: 7/1/2019 - 6/30/2020
Wage Rate Per Hour: 53% of Journeyman's rate
Supplemental Benefit Rate Per Hour: \$14.04

Cement & Concrete Worker (Hired after 2/6/2016 - Second 1334 hours)

Effective Period: 7/1/2019 - 6/30/2020
Wage Rate Per Hour: 69% of Journeyman's rate
Supplemental Benefit Rate Per Hour: \$18.97

Cement & Concrete Worker (Hired after 2/6/2016 - Last 1334 hours)

Effective Period: 7/1/2019 - 6/30/2020
Wage Rate Per Hour: 85% of Journeyman's rate
Supplemental Benefit Rate Per Hour: \$20.05

(Cement Concrete Workers District Council)

DERRICKPERSON & RIGGER (STONE)

(Ratio of Apprentice to Journeyman: 1 to 1, 1 to 4)

OFFICE OF THE COMPTROLLER, CITY OF NEW YORK
CONSTRUCTION APPRENTICE PREVAILING WAGE SCHEDULE

Derrickperson & Rigger (stone) - First Year

Effective Period: 7/1/2019 - 6/30/2020
Wage Rate Per Hour: 50% of Journeyperson's rate
Supplemental Benefit Rate Per Hour: 50% of Journeyperson's rate

Derrickperson & Rigger (stone) - Second Year: 1st Six Months

Effective Period: 7/1/2019 - 6/30/2020
Wage Rate Per Hour: 70% of Journeyperson's rate
Supplemental Benefit Rate Per Hour: 75% of Journeyperson's rate

Derrickperson & Rigger (stone) - Second Year: 2nd Six Months

Effective Period: 7/1/2019 - 6/30/2020
Wage Rate Per Hour: 80% of Journeyperson's rate
Supplemental Benefit Rate Per Hour: 75% of Journeyperson's rate

Derrickperson & Rigger (stone) - Third Year

Effective Period: 7/1/2019 - 6/30/2020
Wage Rate Per Hour: 90% of Journeyperson's rate
Supplemental Benefit Rate Per Hour: 75% of Journeyperson's rate

(Local #197)

DOCKBUILDER/PILE DRIVER
(Ratio of Apprentice to Journeyperson: 1 to 1, 1 to 6)

Dockbuilder/Pile Driver (First Year)

Effective Period: 7/1/2019 - 6/30/2020
Wage Rate Per Hour: 40% of Journeyperson's rate
Supplemental Benefit Rate Per Hour: \$34.12

Dockbuilder/Pile Driver (Second Year)

Effective Period: 7/1/2019 - 6/30/2020
Wage Rate Per Hour: 50% of Journeyperson's rate
Supplemental Benefit Rate Per Hour: \$34.12

Dockbuilder/Pile Driver (Third Year)

Effective Period: 7/1/2019 - 6/30/2020

OFFICE OF THE COMPTROLLER, CITY OF NEW YORK
CONSTRUCTION APPRENTICE PREVAILING WAGE SCHEDULE

Wage Rate Per Hour: 65% of Journeyperson's rate
Supplemental Benefit Rate Per Hour: \$34.12

Dockbuilder/Pile Driver (Fourth Year)

Effective Period: 7/1/2019 - 6/30/2020
Wage Rate Per Hour: 80% of Journeyperson's rate
Supplemental Benefit Rate Per Hour: \$34.12

(Carpenters District Council)

ELECTRICIAN
(Ratio of Apprentice to Journeyperson: 1 to 1, 1 to 3)

Electrician (First Term: 0-6 Months)

Effective Period: 7/1/2019 - 6/30/2020
Wage Rate per Hour: \$15.75
Supplemental Benefit Rate per Hour: \$14.03
Overtime Supplemental Rate Per Hour: \$15.07

Electrician (First Term: 7-12 Months)

Effective Period: 7/1/2019 - 6/30/2020
Wage Rate per Hour: \$16.25
Supplemental Benefit Rate per Hour: \$14.28
Overtime Supplemental Rate Per Hour: \$15.36

Electrician (Second Term: 0-6 Months)

Effective Period: 7/1/2019 - 6/30/2020
Wage Rate per Hour: \$17.25
Supplemental Benefit Rate per Hour: \$14.79
Overtime Supplemental Rate Per Hour: \$15.94

Electrician (Second Term: 7-12 Months)

Effective Period: 7/1/2019 - 6/30/2020
Wage Rate per Hour: \$18.25
Supplemental Benefit Rate per Hour: \$15.30
Overtime Supplemental Rate Per Hour: \$16.51

Electrician (Third Term: 0-6 Months)

OFFICE OF THE COMPTROLLER, CITY OF NEW YORK
CONSTRUCTION APPRENTICE PREVAILING WAGE SCHEDULE

Effective Period: 7/1/2019 - 6/30/2020
Wage Rate per Hour: \$19.25
Supplemental Benefit Rate per Hour: \$15.81
Overtime Supplemental Rate Per Hour: \$17.09

Electrician (Third Term: 7-12 Months)

Effective Period: 7/1/2019 - 6/30/2020
Wage Rate per Hour: \$20.25
Supplemental Benefit Rate per Hour: \$16.32
Overtime Supplemental Rate Per Hour: \$17.67

Electrician (Fourth Term: 0-6 Months)

Effective Period: 7/1/2019 - 6/30/2020
Wage Rate per Hour: \$21.25
Supplemental Benefit Rate per Hour: \$16.83
Overtime Supplemental Rate Per Hour: \$18.24

Electrician (Fourth Term: 7-12 Months)

Effective Period: 7/1/2019 - 6/30/2020
Wage Rate per Hour: \$23.25
Supplemental Benefit Rate per Hour: \$17.85
Overtime Supplemental Rate Per Hour: \$19.39

Electrician (Fifth Term: 0-12 Months)

Effective Period: 7/1/2019 - 6/30/2020
Wage Rate per Hour: \$24.50
Supplemental Benefit Rate per Hour: \$21.07
Overtime Supplemental Rate Per Hour: \$22.62

Electrician (Fifth Term: 13-18 Months)

Effective Period: 7/1/2019 - 6/30/2020
Wage Rate per Hour: \$29.00
Supplemental Benefit Rate per Hour: \$23.43
Overtime Supplemental Rate Per Hour: \$25.26

Overtime Description

Overtime Wage paid at time and one half the regular rate

(Local #3)

OFFICE OF THE COMPTROLLER, CITY OF NEW YORK
CONSTRUCTION APPRENTICE PREVAILING WAGE SCHEDULE

ELEVATOR CONSTRUCTOR

(Ratio of Apprentice to Journeyman: 1 to 1, 1 to 2)

Elevator (Constructor) - First Year

Effective Period: 7/1/2019 - 3/16/2020
Wage Rate Per Hour: 50% of Journeyman's rate
Supplemental Rate Per Hour: \$31.52

Effective Period: 3/17/2020 - 6/30/2020
Wage Rate Per Hour: 50% of Journeyman's rate
Supplemental Rate Per Hour: \$32.14

Elevator (Constructor) - Second Year

Effective Period: 7/1/2019 - 3/16/2020
Wage Rate Per Hour: 55% of Journeyman's rate
Supplemental Rate Per Hour: \$32.03

Effective Period: 3/17/2020 - 6/30/2020
Wage Rate Per Hour: 55% of Journeyman's rate
Supplemental Rate Per Hour: \$32.67

Elevator (Constructor) - Third Year

Effective Period: 7/1/2019 - 3/16/2020
Wage Rate Per Hour: 65% of Journeyman's rate
Supplemental Rate Per Hour: \$33.06

Effective Period: 3/17/2020 - 6/30/2020
Wage Rate Per Hour: 65% of Journeyman's rate
Supplemental Rate Per Hour: \$33.74

Elevator (Constructor) - Fourth Year

Effective Period: 7/1/2019 - 3/16/2020
Wage Rate Per Hour: 75% of Journeyman's rate
Supplemental Rate Per Hour: \$34.08

Effective Period: 3/17/2020 - 6/30/2020
Wage Rate Per Hour: 75% of Journeyman's rate
Supplemental Rate Per Hour: \$34.80

(Local #1)

OFFICE OF THE COMPTROLLER, CITY OF NEW YORK
CONSTRUCTION APPRENTICE PREVAILING WAGE SCHEDULE

ELEVATOR REPAIR & MAINTENANCE
(Ratio of Apprentice to Journeyman: 1 to 1, 1 to 2)

Elevator Service/Modernization Mechanic (First Year)

Effective Period: 7/1/2019 - 3/16/2020
Wage Rate Per Hour: 50% of Journeyman's rate
Supplemental Benefit Per Hour: \$31.47

Effective Period: 3/17/2020 - 6/30/2020
Wage Rate Per Hour: 50% of Journeyman's rate
Supplemental Benefit Per Hour: \$32.09

Elevator Service/Modernization Mechanic (Second Year)

Effective Period: 7/1/2019 - 3/16/2020
Wage Rate Per Hour: 55% of Journeyman's rate
Supplemental Benefit Per Hour: \$31.98

Effective Period: 3/17/2020 - 6/30/2020
Wage Rate Per Hour: 55% of Journeyman's rate
Supplemental Benefit Per Hour: \$32.62

Elevator Service/Modernization Mechanic (Third Year)

Effective Period: 7/1/2019 - 3/16/2020
Wage Rate Per Hour: 65% of Journeyman's rate
Supplemental Benefit Per Hour: \$32.99

Effective Period: 3/17/2020 - 6/30/2020
Wage Rate Per Hour: 65% of Journeyman's rate
Supplemental Benefit Per Hour: \$33.67

Elevator Service/Modernization Mechanic (Fourth Year)

Effective Period: 7/1/2019 - 3/16/2020
Wage Rate Per Hour: 75% of Journeyman's rate
Supplemental Benefit Per Hour: \$34.01

Effective Period: 3/17/2020 - 6/30/2020
Wage Rate Per Hour: 75% of Journeyman's rate
Supplemental Benefit Per Hour: \$34.73

(Local #1)

OFFICE OF THE COMPTROLLER, CITY OF NEW YORK
CONSTRUCTION APPRENTICE PREVAILING WAGE SCHEDULE

ENGINEER

(Ratio of Apprentice to Journeyman: 1 to 1, 1 to 5)

Engineer - First Year

Effective Period: 7/1/2019 - 6/30/2020
Wage Rate per Hour: \$25.38
Supplemental Benefit Rate per Hour: \$26.69

Engineer - Second Year

Effective Period: 7/1/2019 - 6/30/2020
Wage Rate per Hour: \$31.72
Supplemental Benefit Rate per Hour: \$26.69

Engineer - Third Year

Effective Period: 7/1/2019 - 6/30/2020
Wage Rate per Hour: \$34.89
Supplemental Benefit Rate per Hour: \$26.69

Engineer - Fourth Year

Effective Period: 7/1/2019 - 6/30/2020
Wage Rate per Hour: \$38.06
Supplemental Benefit Rate per Hour: \$26.69

(Local #15)

ENGINEER - OPERATING

(Ratio of Apprentice to Journeyman: 1 to 1, 1 to 5)

Operating Engineer - First Year

Effective Period: 7/1/2019 - 6/30/2020
Wage Rate Per Hour 40% of Journeyman's Rate
Supplemental Benefit Per Hour: \$22.45

Operating Engineer - Second Year

Effective Period: 7/1/2019 - 6/30/2020
Wage Rate Per Hour: 50% of Journeyman's Rate

OFFICE OF THE COMPTROLLER, CITY OF NEW YORK
CONSTRUCTION APPRENTICE PREVAILING WAGE SCHEDULE

Supplemental Benefit Per Hour: \$22.45

Operating Engineer - Third Year

Effective Period: 7/1/2019 - 6/30/2020
Wage Rate Per Hour: 60% of Journeyman's Rate
Supplemental Benefit Per Hour: \$22.45

(Local #14)

FLOOR COVERER

(Ratio of Apprentice to Journeyman: 1 to 1, 1 to 4)

Floor Coverer (First Year)

Effective Period: 7/1/2019 - 6/30/2020
Wage Rate Per Hour: 40% of Journeyman's rate
Supplemental Rate Per Hour: \$31.24

Floor Coverer (Second Year)

Effective Period: 7/1/2019 - 6/30/2020
Wage Rate Per Hour: 50% of Journeyman's rate
Supplemental Rate Per Hour: \$31.24

Floor Coverer (Third Year)

Effective Period: 7/1/2019 - 6/30/2020
Wage Rate Per Hour: 65% of Journeyman's rate
Supplemental Rate Per Hour: \$31.24

Floor Coverer (Fourth Year)

Effective Period: 7/1/2019 - 6/30/2020
Wage Rate Per Hour: 80% of Journeyman's rate
Supplemental Rate Per Hour: \$31.24

(Carpenters District Council)

OFFICE OF THE COMPTROLLER, CITY OF NEW YORK
CONSTRUCTION APPRENTICE PREVAILING WAGE SCHEDULE

GLAZIER

(Ratio of Apprentice to Journeyman: 1 to 1, 1 to 3)

Glazier (First Year)

Effective Period: 7/1/2019 - 6/30/2020
Wage and Supplemental Rate Per Hour: 40% of Journeyman's rate

Glazier (Second Year)

Effective Period: 7/1/2019 - 6/30/2020
Wage and Supplemental Rate Per Hour: 50% of Journeyman's rate

Glazier (Third Year)

Effective Period: 7/1/2019 - 6/30/2020
Wage and Supplemental Rate Per Hour: 60% of Journeyman's rate

Glazier (Fourth Year)

Effective Period: 7/1/2019 - 6/30/2020
Wage and Supplemental Rate Per Hour: 80% of Journeyman's rate

(Local #1281)

HAZARDOUS MATERIAL HANDLER

(Ratio of Apprentice Journeyman: 1 to 1, 1 to 3)

Handler (First 1000 Hours)

Effective Period: 7/1/2019 - 6/30/2020
Wage Rate Per Hour: 78% of Journeyman's rate
Supplemental Benefit Rate Per Hour: \$14.25

Handler (Second 1000 Hours)

Effective Period: 7/1/2019 - 6/30/2020
Wage Rate Per Hour: 80% of Journeyman's rate
Supplemental Benefit Rate Per Hour: \$14.25

Handler (Third 1000 Hours)

Effective Period: 7/1/2019 - 6/30/2020

OFFICE OF THE COMPTROLLER, CITY OF NEW YORK
CONSTRUCTION APPRENTICE PREVAILING WAGE SCHEDULE

Wage Rate Per Hour: 83% of Journeyman's rate
Supplemental Benefit Rate Per Hour: \$14.25

Handler (Fourth 1000 Hours)

Effective Period: 7/1/2019 - 6/30/2020
Wage Rate Per Hour: 89% of Journeyman's rate
Supplemental Benefit Rate Per Hour: \$14.25

(Local #78)

HEAT & FROST INSULATOR
(Ratio of Apprentice to Journeyman: 1 to 1, 1 to 3)

Heat & Frost Insulator (First Year)

Effective Period: 7/1/2019 - 6/30/2020
Wage and Supplemental Rate Per Hour: 35% of Journeyman's rate

Heat & Frost Insulator (Second Year)

Effective Period: 7/1/2019 - 6/30/2020
Wage and Supplemental Rate Per Hour: 45% of Journeyman's rate

Heat & Frost Insulator (Third Year)

Effective Period: 7/1/2019 - 6/30/2020
Wage and Supplemental Rate Per Hour: 55% of Journeyman's rate

Heat & Frost Insulator (Fourth Year)

Effective Period: 7/1/2019 - 6/30/2020
Wage and Supplemental Rate Per Hour: 65% of Journeyman's rate

(Local #12)

HOUSE WRECKER
(TOTAL DEMOLITION)
(Ratio of Apprentice to Journeyman: 1 to 1, 1 to 3)

OFFICE OF THE COMPTROLLER, CITY OF NEW YORK
CONSTRUCTION APPRENTICE PREVAILING WAGE SCHEDULE

House Wrecker - First Year

Effective Period: 7/1/2019 - 6/30/2020
Wage Rate per Hour: \$21.17
Supplemental Benefit Rate per Hour: \$19.09

House Wrecker - Second Year

Effective Period: 7/1/2019 - 6/30/2020
Wage Rate per Hour: \$22.32
Supplemental Benefit Rate per Hour: \$19.09

House Wrecker - Third Year

Effective Period: 7/1/2019 - 6/30/2020
Wage Rate per Hour: \$23.97
Supplemental Benefit Rate per Hour: \$19.09

House Wrecker - Fourth Year

Effective Period: 7/1/2019 - 6/30/2020
Wage Rate per Hour: \$26.53
Supplemental Benefit Rate per Hour: \$19.09

(Mason Tenders District Council)

IRON WORKER - ORNAMENTAL
(Ratio of Apprentice to Journeyman: 1 to 1, 1 to 4)

Iron Worker (Ornamental) - 1st Ten Months

Effective Period: 7/1/2019 - 6/30/2020
Wage Rate Per Hour: 50% of Journeyman's rate
Supplemental Rate Per Hour: \$40.20

Iron Worker (Ornamental) - 11 -16 Months

Effective Period: 7/1/2019 - 6/30/2020
Wage Rate Per Hour: 55% of Journeyman's rate
Supplemental Rate Per Hour: \$41.44

OFFICE OF THE COMPTROLLER, CITY OF NEW YORK
CONSTRUCTION APPRENTICE PREVAILING WAGE SCHEDULE

Iron Worker (Ornamental) - 17 - 22 Months

Effective Period: 7/1/2019 - 6/30/2020
Wage Rate Per Hour: 60% of Journeyperson's rate
Supplemental Rate Per Hour: \$42.68

Iron Worker (Ornamental) - 23 - 28 Months

Effective Period: 7/1/2019 - 6/30/2020
Wage Rate Per Hour: 70% of Journeyperson's rate
Supplemental Rate Per Hour: \$45.17

Iron Worker (Ornamental) - 29 - 36 Months

Effective Period: 7/1/2019 - 6/30/2020
Wage Rate Per Hour: 80% of Journeyperson's rate
Supplemental Rate Per Hour: \$47.65

(Local #580)

IRON WORKER - STRUCTURAL
(Ratio of Apprentice to Journeyperson: 1 to 1, 1 to 6)

Iron Worker (Structural) - 1st Six Months

Effective Period: 7/1/2019 - 6/30/2020
Wage Rate per Hour: \$26.62
Supplemental Benefit Rate per Hour: \$53.09

Iron Worker (Structural) - 7- 18 Months

Effective Period: 7/1/2019 - 6/30/2020
Wage Rate per Hour: \$27.22
Supplemental Benefit Rate per Hour: \$53.09

Iron Worker (Structural) - 19 - 36 months

Effective Period: 7/1/2019 - 6/30/2020
Wage Rate per Hour: \$27.83
Supplemental Benefit Rate per Hour: \$53.09

(Local #40 and #361)

OFFICE OF THE COMPTROLLER, CITY OF NEW YORK
CONSTRUCTION APPRENTICE PREVAILING WAGE SCHEDULE

**LABORER (FOUNDATION, CONCRETE, EXCAVATING, STREET PIPE
LAYER & COMMON)**

(Ratio Apprentice to Journeyman: 1 to 1, 1 to 3)

**Laborer (Foundation, Concrete, Excavating, Street Pipe Layer & Common) - First
1000 hours**

Effective Period: 7/1/2019 - 6/30/2020
Wage Rate Per Hour: 50% of Journeyman's rate
Supplemental Rate Per Hour: \$44.48

**Laborer (Foundation, Concrete, Excavating, Street Pipe Layer & Common) -
Second 1000 hours**

Effective Period: 7/1/2019 - 6/30/2020
Wage Rate Per Hour: 60% of Journeyman's rate
Supplemental Rate Per Hour: \$44.48

**Laborer (Foundation, Concrete, Excavating, Street Pipe Layer & Common) -
Third 1000 hours**

Effective Period: 7/1/2019 - 6/30/2020
Wage Rate Per Hour: 75% of Journeyman's rate
Supplemental Rate Per Hour: \$44.48

**Laborer (Foundation, Concrete, Excavating, Street Pipe Layer & Common) -
Fourth 1000 hours**

Effective Period: 7/1/2019 - 6/30/2020
Wage Rate Per Hour: 90% of Journeyman's rate
Supplemental Rate Per Hour: \$44.48

(Local #731)

MARBLE MECHANICS

(Ratio of Apprentice to Journeyman: 1 to 1, 1 to 4)

Cutters & Setters - First 750 Hours

OFFICE OF THE COMPTROLLER, CITY OF NEW YORK
CONSTRUCTION APPRENTICE PREVAILING WAGE SCHEDULE

Effective Period: 7/1/2019 - 6/30/2020
Wage and Supplemental Rate Per Hour: 40% of Journeyperson's rate

NO BENEFITS PAID DURING THE FIRST TWO MONTHS (PROBATIONARY PERIOD)

Cutters & Setters - Second 750 Hours

Effective Period: 7/1/2019 - 6/30/2020
Wage and Supplemental Rate Per Hour: 45% of Journeyperson's rate

Cutters & Setters - Third 750 Hours

Effective Period: 7/1/2019 - 6/30/2020
Wage and Supplemental Rate Per Hour: 50% of Journeyperson's rate

Cutters & Setters - Fourth 750 Hours

Effective Period: 7/1/2019 - 6/30/2020
Wage and Supplemental Rate Per Hour: 55% of Journeyperson's rate

Cutters & Setters - Fifth 750 Hours

Effective Period: 7/1/2019 - 6/30/2020
Wage and Supplemental Rate Per Hour: 60% of Journeyperson's rate

Cutters & Setters - Sixth 750 Hours

Effective Period: 7/1/2019 - 6/30/2020
Wage and Supplemental Rate Per Hour: 65% of Journeyperson's rate

Cutters & Setters - Seventh 750 Hours

Effective Period: 7/1/2019 - 6/30/2020
Wage and Supplemental Rate Per Hour: 70% of Journeyperson's rate

Cutters & Setters - Eighth 750 Hours

Effective Period: 7/1/2019 - 6/30/2020
Wage and Supplemental Rate Per Hour: 75% of Journeyperson's rate

Cutters & Setters - Ninth 750 Hours

Effective Period: 7/1/2019 - 6/30/2020
Wage and Supplemental Rate Per Hour: 85% of Journeyperson's rate

Cutters & Setters - Tenth 750 Hours

Effective Period: 7/1/2019 - 6/30/2020
Wage and Supplemental Rate Per Hour: 95% of Journeyperson's rate

OFFICE OF THE COMPTROLLER, CITY OF NEW YORK
CONSTRUCTION APPRENTICE PREVAILING WAGE SCHEDULE

Polishers & Finishers - First 900 Hours

Effective Period: 7/1/2019 - 6/30/2020
Wage and Supplemental Rate Per Hour: 70% of Journeyperson's rate

NO BENEFITS PAID DURING THE FIRST TWO MONTHS (PROBATIONARY PERIOD)

Polishers & Finishers - Second 900 Hours

Effective Period: 7/1/2019 - 6/30/2020
Wage and Supplemental Rate Per Hour: 80% of Journeyperson's rate

Polishers & Finishers - Third 900 Hours

Effective Period: 7/1/2019 - 6/30/2020
Wage and Supplemental Rate Per Hour: 90% of Journeyperson's rate

(Local #7)

MASON TENDER
(Ratio of Apprentice to Journeyperson: 1 to 1, 1 to 3)

Mason Tender - First Year

Effective Period: 7/1/2019 - 6/30/2020
Wage Rate per Hour: \$21.39
Supplemental Benefit Rate per Hour: \$19.90

Mason Tender - Second Year

Effective Period: 7/1/2019 - 6/30/2020
Wage Rate per Hour: \$22.54
Supplemental Benefit Rate per Hour: \$19.90

Mason Tender - Third Year

Effective Period: 7/1/2019 - 6/30/2020
Wage Rate per Hour: \$24.29
Supplemental Benefit Rate per Hour: \$19.90

Mason Tender - Fourth Year

OFFICE OF THE COMPTROLLER, CITY OF NEW YORK
CONSTRUCTION APPRENTICE PREVAILING WAGE SCHEDULE

Effective Period: 7/1/2019 - 6/30/2020
Wage Rate per Hour: \$26.95
Supplemental Benefit Rate per Hour: \$19.90

(Local #79)

METALLIC LATHER
(Ratio of Apprentice to Journeyperson: 1 to 1, 1 to 3)

Metallic Lather (First Year)

Effective Period: 7/1/2019 - 6/30/2020
Wage Rate per Hour: \$23.04
Supplemental Benefit Rate per Hour: \$20.00

Metallic Lather (Second Year)

Effective Period: 7/1/2019 - 6/30/2020
Wage Rate per Hour: \$28.38
Supplemental Benefit Rate per Hour: \$20.66

Metallic Lather (Third Year)

Effective Period: 7/1/2019 - 6/30/2020
Wage Rate per Hour: \$34.68
Supplemental Benefit Rate per Hour: \$21.32

Metallic Lather (Fourth Year)

Effective Period: 7/1/2019 - 6/30/2020
Wage Rate per Hour: \$37.18
Supplemental Benefit Rate per Hour: \$21.82

(Local #46)

MILLWRIGHT
(Ratio of Apprentice to Journeyperson: 1 to 1, 1 to 4)

OFFICE OF THE COMPTROLLER, CITY OF NEW YORK
CONSTRUCTION APPRENTICE PREVAILING WAGE SCHEDULE

Millwright (First Year)

Effective Period: 7/1/2019 - 6/30/2020
Wage Rate per Hour: \$29.16
Supplemental Benefit Rate per Hour: \$34.66

Millwright (Second Year)

Effective Period: 7/1/2019 - 6/30/2020
Wage Rate per Hour: \$34.46
Supplemental Benefit Rate per Hour: \$38.31

Millwright (Third Year)

Effective Period: 7/1/2019 - 6/30/2020
Wage Rate per Hour: \$39.76
Supplemental Benefit Rate per Hour: \$42.61

Millwright (Fourth Year)

Effective Period: 7/1/2019 - 6/30/2020
Wage Rate per Hour: \$50.36
Supplemental Benefit Rate per Hour: \$49.27

(Local #740)

PAINTER

(Ratio of Apprentice to Journeyperson: 1 to 1, 1 to 3)

Painter - Brush & Roller - First Year

Effective Period: 7/1/2019 - 6/30/2020
Wage Rate per Hour: \$17.20
Supplemental Benefit Rate per Hour: \$15.05

Painter - Brush & Roller - Second Year

Effective Period: 7/1/2019 - 6/30/2020
Wage Rate per Hour: \$21.50
Supplemental Benefit Rate per Hour: \$19.39

OFFICE OF THE COMPTROLLER, CITY OF NEW YORK
CONSTRUCTION APPRENTICE PREVAILING WAGE SCHEDULE

Painter - Brush & Roller - Third Year

Effective Period: 7/1/2019 - 6/30/2020
Wage Rate per Hour: **\$25.80**
Supplemental Benefit Rate per Hour: **\$22.79**

Painter - Brush & Roller - Fourth Year

Effective Period: 7/1/2019 - 6/30/2020
Wage Rate per Hour: **\$34.40**
Supplemental Benefit Rate per Hour: **\$29.16**

(District Council of Painters)

PAINTER - METAL POLISHER
(Ratio of Apprentice to Journeyperson: 1 to 1, 1 to 3)

Metal Polisher (First Year)

Effective Period: 7/1/2019 - 6/30/2020
Wage Rate per Hour: **\$13.00**
Supplemental Benefit Rate per Hour: **\$5.13**

Metal Polisher (Second Year)

Effective Period: 7/1/2019 - 6/30/2020
Wage Rate per Hour: **\$13.00**
Supplemental Benefit Rate per Hour: **\$5.13**

Metal Polisher (Third Year)

Effective Period: 7/1/2019 - 6/30/2020
Wage Rate per Hour: **\$15.75**
Supplemental Benefit Rate per Hour: **\$5.13**

(Local 8A-28)

OFFICE OF THE COMPTROLLER, CITY OF NEW YORK
CONSTRUCTION APPRENTICE PREVAILING WAGE SCHEDULE

PAINTER - STRUCTURAL STEEL
(Ratio of Apprentice to Journeyman: 1 to 1, 1 to 3)

Painters - Structural Steel (First Year)

Effective Period: 7/1/2019 - 6/30/2020
Wage and Supplemental Rate Per Hour: 40% of Journeyman's rate

Painters - Structural Steel (Second Year)

Effective Period: 7/1/2019 - 6/30/2020
Wage and Supplemental Rate Per Hour: 60% of Journeyman's rate

Painters - Structural Steel (Third Year)

Effective Period: 7/1/2019 - 6/30/2020
Wage and Supplemental Rate Per Hour: 80% of Journeyman's rate

(Local #806)

PAVER AND ROADBUILDER
(Ratio of Apprentice to Journeyman: 1 to 1, 1 to 3)

Paver and Roadbuilder - First Year (Minimum 1000 hours)

Effective Period: 7/1/2019 - 6/30/2020
Wage Rate per Hour: \$28.86
Supplemental Benefit Rate per Hour: \$21.40

Paver and Roadbuilder - Second Year (Minimum 1000 hours)

Effective Period: 7/1/2019 - 6/30/2020
Wage Rate per Hour: \$30.50
Supplemental Benefit Rate per Hour: \$21.40

(Local #1010)

OFFICE OF THE COMPTROLLER, CITY OF NEW YORK
CONSTRUCTION APPRENTICE PREVAILING WAGE SCHEDULE

PLASTERER

(Ratio of Apprentice to Journeyman: 1 to 1, 1 to 3)

Plasterer - First Year: 1st Six Months

Effective Period: 7/1/2019 - 6/30/2020
Wage Rate Per Hour: 40% of Journeyman's rate
Supplemental Rate Per Hour: \$13.88

Plasterer - First Year: 2nd Six Months

Effective Period: 7/1/2019 - 6/30/2020
Wage Rate Per Hour: 45% of Journeyman's rate
Supplemental Rate Per Hour: \$14.36

Plasterer - Second Year: 1st Six Months

Effective Period: 7/1/2019 - 6/30/2020
Wage Rate Per Hour: 55% of Journeyman's rate
Supplemental Rate Per Hour: \$16.44

Plasterer - Second Year: 2nd Six Months

Effective Period: 7/1/2019 - 6/30/2020
Wage Rate Per Hour: 60% of Journeyman's rate
Supplemental Rate Per Hour: \$17.53

Plasterer - Third Year: 1st Six Months

Effective Period: 7/1/2019 - 6/30/2020
Wage Rate Per Hour: 70% of Journeyman's rate
Supplemental Rate Per Hour: \$19.72

Plasterer - Third Year: 2nd Six Months

Effective Period: 7/1/2019 - 6/30/2020
Wage Rate Per Hour: 75% of Journeyman's rate
Supplemental Rate Per Hour: \$20.81

(Local #530)

PLASTERER - TENDER

(Ratio of Apprentice to Journeyman: 1 to 1, 1 to 3)

OFFICE OF THE COMPTROLLER, CITY OF NEW YORK
CONSTRUCTION APPRENTICE PREVAILING WAGE SCHEDULE

Plasterer Tender - First Year

Effective Period: 7/1/2019 - 6/30/2020

Wage Rate per Hour: \$21.39

Supplemental Benefit Rate per Hour: \$19.90

Plasterer Tender - Second Year

Effective Period: 7/1/2019 - 6/30/2020

Wage Rate per Hour: \$22.54

Supplemental Benefit Rate per Hour: \$19.90

Plasterer Tender - Third Year

Effective Period: 7/1/2019 - 6/30/2020

Wage Rate per Hour: \$24.29

Supplemental Benefit Rate per Hour: \$19.90

Plasterer Tender - Fourth Year

Effective Period: 7/1/2019 - 6/30/2020

Wage Rate per Hour: \$26.95

Supplemental Benefit Rate per Hour: \$19.90

(Local #79)

PLUMBER

(Ratio of Apprentice to Journeyman: 1 to 1, 1 to 3)

Plumber - First Year: 1st Six Months

Effective Period: 7/1/2019 - 6/30/2020

Wage Rate per Hour: \$16.28

Supplemental Benefit Rate per Hour: \$5.43

Plumber - First Year: 2nd Six Months

Effective Period: 7/1/2019 - 6/30/2020

Wage Rate per Hour: \$19.28

Supplemental Benefit Rate per Hour: \$6.43

OFFICE OF THE COMPTROLLER, CITY OF NEW YORK
CONSTRUCTION APPRENTICE PREVAILING WAGE SCHEDULE

Plumber - Second Year

Effective Period: 7/1/2019 - 6/30/2020
Wage Rate per Hour: \$27.23
Supplemental Benefit Rate per Hour: \$19.80

Plumber - Third Year

Effective Period: 7/1/2019 - 6/30/2020
Wage Rate per Hour: \$29.33
Supplemental Benefit Rate per Hour: \$19.80

Plumber - Fourth Year

Effective Period: 7/1/2019 - 6/30/2020
Wage Rate per Hour: \$32.18
Supplemental Benefit Rate per Hour: \$19.80

Plumber - Fifth Year: 1st Six Months

Effective Period: 7/1/2019 - 6/30/2020
Wage Rate per Hour: \$33.58
Supplemental Benefit Rate per Hour: \$19.80

Plumber - Fifth Year: 2nd Six Months

Effective Period: 7/1/2019 - 6/30/2020
Wage Rate per Hour: \$45.65
Supplemental Benefit Rate per Hour: \$19.80

(Plumbers Local #1)

**POINTER, WATERPROOFER, CAULKER, SANDBLASTER,
STEAMBLASTER
(Exterior Building Renovation)
(Ratio of Apprentice to Journeyperson: 1 to 1, 1 to 4)**

Pointer, Waterproofer, Caulker, Sandblaster, Steamblaster - First Year

Effective Period: 7/1/2019 - 6/30/2020
Wage Rate per Hour: \$26.36
Supplemental Benefit Rate per Hour: \$14.00

OFFICE OF THE COMPTROLLER, CITY OF NEW YORK
CONSTRUCTION APPRENTICE PREVAILING WAGE SCHEDULE

Pointer, Waterproofer, Caulker, Sandblaster, Steamblaster - Second Year

Effective Period: 7/1/2019 - 6/30/2020
Wage Rate per Hour: \$29.42
Supplemental Benefit Rate per Hour: \$18.97

Pointer, Waterproofer, Caulker, Sandblaster, Steamblaster - Third Year

Effective Period: 7/1/2019 - 6/30/2020
Wage Rate per Hour: \$34.80
Supplemental Benefit Rate per Hour: \$21.72

Pointer, Waterproofer, Caulker, Sandblaster, Steamblaster - Fourth Year

Effective Period: 7/1/2019 - 6/30/2020
Wage Rate per Hour: \$41.93
Supplemental Benefit Rate per Hour: \$22.72

(Bricklayer District Council)

ROOFER

(Ratio of Apprentice to Journeyman: 1 to 1, 1 to 2)

Roofer - First Year

Effective Period: 7/1/2019 - 6/30/2020
Wage Rate Per Hour: 35% of Journeyman's rate
Supplemental Benefit Rate Per Hour: \$3.36

Roofer - Second Year

Effective Period: 7/1/2019 - 6/30/2020
Wage Rate Per Hour: 50% of Journeyman's rate
Supplemental Benefit Rate Per Hour: \$16.92

Roofer - Third Year

Effective Period: 7/1/2019 - 6/30/2020
Wage Rate Per Hour: 60% of Journeyman's rate
Supplemental Benefit Rate Per Hour: \$20.29

Roofer - Fourth Year

OFFICE OF THE COMPTROLLER, CITY OF NEW YORK
CONSTRUCTION APPRENTICE PREVAILING WAGE SCHEDULE

Effective Period: 7/1/2019 - 6/30/2020
Wage Rate Per Hour: 75% of Journeyman's rate
Supplemental Benefit Rate Per Hour: \$25.37

(Local #8)

SHEET METAL WORKER
(Ratio of Apprentice to Journeyman: 1 to 1, 1 to 3)

Sheet Metal Worker (0-6 Months)

Effective Period: 7/1/2019 - 6/30/2020
Wage Rate Per Hour: 25% of Journeyman's rate
Supplemental Rate Per Hour: \$6.51

Sheet Metal Worker (7-18 Months)

Effective Period: 7/1/2019 - 6/30/2020
Wage Rate Per Hour: 35% of Journeyman's rate
Supplemental Rate Per Hour: \$18.57

Sheet Metal Worker (19-30 Months)

Effective Period: 7/1/2019 - 6/30/2020
Wage Rate Per Hour: 45% of Journeyman's rate
Supplemental Rate Per Hour: \$25.40

Sheet Metal Worker (31-36 Months)

Effective Period: 7/1/2019 - 6/30/2020
Wage Rate Per Hour: 55% of Journeyman's rate
Supplemental Rate Per Hour: \$29.95

Sheet Metal Worker (37-42 Months)

Effective Period: 7/1/2019 - 6/30/2020
Wage Rate Per Hour: 55% of Journeyman's rate
Supplemental Rate Per Hour: \$29.95

Sheet Metal Worker (43-48 Months)

Effective Period: 7/1/2019 - 6/30/2020
Wage Rate Per Hour: 70% of Journeyman's rate
Supplemental Rate Per Hour: \$36.83

OFFICE OF THE COMPTROLLER, CITY OF NEW YORK
CONSTRUCTION APPRENTICE PREVAILING WAGE SCHEDULE

Sheet Metal Worker (49-54 Months)

Effective Period: 7/1/2019 - 6/30/2020
Wage Rate Per Hour: 70% of Journeyman's rate
Supplemental Rate Per Hour: \$36.83

Sheet Metal Worker (55-60 Months)

Effective Period: 7/1/2019 - 6/30/2020
Wage Rate Per Hour: 80% of Journeyman's rate
Supplemental Rate Per Hour: \$41.42

(Local #28)

SIGN ERECTOR

(Ratio of Apprentice to Journeyman: 1 to 1, 1 to 4)

Sign Erector - First Year: 1st Six Months

Effective Period: 7/1/2019 - 6/30/2020
Wage Rate Per Hour: 35% of Journeyman's rate
Supplemental Rate Per Hour: \$15.75

Sign Erector - First Year: 2nd Six Months

Effective Period: 7/1/2019 - 6/30/2020
Wage Rate Per Hour: 40% of Journeyman's rate
Supplemental Rate Per Hour: \$17.86

Sign Erector - Second Year: 1st Six Months

Effective Period: 7/1/2019 - 6/30/2020
Wage Rate Per Hour: 45% of Journeyman's rate
Supplemental Rate Per Hour: \$19.98

Sign Erector - Second Year: 2nd Six Months

Effective Period: 7/1/2019 - 6/30/2020
Wage Rate Per Hour: 50% of Journeyman's rate
Supplemental Rate Per Hour: \$22.12

Sign Erector - Third Year: 1st Six Months

Effective Period: 7/1/2019 - 6/30/2020

OFFICE OF THE COMPTROLLER, CITY OF NEW YORK
CONSTRUCTION APPRENTICE PREVAILING WAGE SCHEDULE

Wage Rate Per Hour: 55% of Journeyperson's rate
Supplemental Rate Per Hour: \$29.92

Sign Erector - Third Year: 2nd Six Months

Effective Period: 7/1/2019 - 6/30/2020
Wage Rate Per Hour: 60% of Journeyperson's rate
Supplemental Rate Per Hour: \$32.56

Sign Erector - Fourth Year: 1st Six Months

Effective Period: 7/1/2019 - 6/30/2020
Wage Rate Per Hour: 65% of Journeyperson's rate
Supplemental Rate Per Hour: \$35.92

Sign Erector - Fourth Year: 2nd Six Months

Effective Period: 7/1/2019 - 6/30/2020
Wage Rate Per Hour: 70% of Journeyperson's rate
Supplemental Rate Per Hour: \$38.65

Sign Erector - Fifth Year

Effective Period: 7/1/2019 - 6/30/2020
Wage Rate Per Hour: 75% of Journeyperson's rate
Supplemental Rate Per Hour: \$41.33

Sign Erector - Sixth Year

Effective Period: 7/1/2019 - 6/30/2020
Wage Rate Per Hour: 80% of Journeyperson's rate
Supplemental Rate Per Hour: \$44.01

(Local #137)

STEAMFITTER

(Ratio of Apprentice to Journeyperson: 1 to 1, 1 to 3)

Steamfitter - First Year

Effective Period: 7/1/2019 - 6/30/2020
Wage Rate and Supplemental Per Hour: 40% of Journeyperson's rate

Steamfitter - Second Year

OFFICE OF THE COMPTROLLER, CITY OF NEW YORK
CONSTRUCTION APPRENTICE PREVAILING WAGE SCHEDULE

Effective Period: 7/1/2019 - 6/30/2020

Wage Rate and Supplemental Rate Per Hour: 50% of Journeyperson's rate.

Steamfitter - Third Year

Effective Period: 7/1/2019 - 6/30/2020

Wage Rate and Supplemental Rate per Hour: 65% of Journeyperson's rate.

Steamfitter - Fourth Year

Effective Period: 7/1/2019 - 6/30/2020

Wage Rate and Supplemental Rate Per Hour: 80% of Journeyperson's rate.

Steamfitter - Fifth Year

Effective Period: 7/1/2019 - 6/30/2020

Wage Rate and Supplemental Rate Per Hour: 85% of Journeyperson's rate.

(Local #638)

STONE MASON - SETTER

(Ratio Apprentice of Journeyperson: 1 to 1, 1 to 2)

Stone Mason - Setters - First 750 Hours

Effective Period: 7/1/2019 - 6/30/2020

Wage and Supplemental Rate Per Hour: 50% of Journeyperson's rate

Stone Mason - Setters - Second 750 Hours

Effective Period: 7/1/2019 - 6/30/2020

Wage Rate Per Hour: 60% of Journeyperson's rate

Supplemental Rate Per Hour: 50% of Journeyperson's rate

Stone Mason - Setters - Third 750 Hours

Effective Period: 7/1/2019 - 6/30/2020

Wage Rate Per Hour: 70% of Journeyperson's rate

Supplemental Rate Per Hour: 50% of Journeyperson's rate

Stone Mason - Setters - Fourth 750 Hours

Effective Period: 7/1/2019 - 6/30/2020

Wage Rate Per Hour: 80% of Journeyperson's rate

Supplemental Rate Per Hour: 50% of Journeyperson's rate

OFFICE OF THE COMPTROLLER, CITY OF NEW YORK
CONSTRUCTION APPRENTICE PREVAILING WAGE SCHEDULE

Stone Mason - Setters - Fifth 750 Hours

Effective Period: 7/1/2019 - 6/30/2020
Wage Rate Per Hour: 90% of Journeyman's rate
Supplemental Rate Per Hour: 50% of Journeyman's rate

Stone Mason - Setters - Sixth 750 Hours

Effective Period: 7/1/2019 - 6/30/2020
Wage Rate Per Hour: 100% of Journeyman's rate
Supplemental Rate Per Hour: 50% of Journeyman's rate

(Bricklayers District Council)

TAPER

(Ratio of Apprentice to Journeyman: 1 to 1, 1 to 4)

Drywall Taper - First Year

Effective Period: 7/1/2019 - 6/30/2020
Wage and Supplemental Rate Per Hour: 40% of Journeyman's rate

Drywall Taper - Second Year

Effective Period: 7/1/2019 - 6/30/2020
Wage and Supplemental Rate Per Hour: 60% of Journeyman's rate

Drywall Taper - Third Year

Effective Period: 7/1/2019 - 6/30/2020
Wage and Supplemental Rate Per Hour: 80% of Journeyman's rate

(Local #1974)

TILE LAYER - SETTER

(Ratio of Apprentice to Journeyman: 1 to 1, 1 to 4)

OFFICE OF THE COMPTROLLER, CITY OF NEW YORK
CONSTRUCTION APPRENTICE PREVAILING WAGE SCHEDULE

Tile Layer - Setter - First 750 Hours

Effective Period: 7/1/2019 - 6/30/2020
Wage and Supplemental Rate Per Hour: 50% of Journeyman's rate

Tile Layer - Setter - Second 750 Hours

Effective Period: 7/1/2019 - 6/30/2020
Wage and Supplemental Rate Per Hour: 55% of Journeyman's rate

Tile Layer - Setter - Third 750 Hours

Effective Period: 7/1/2019 - 6/30/2020
Wage and Supplemental Rate Per Hour: 65% of Journeyman's rate

Tile Layer - Setter - Fourth 750 Hours

Effective Period: 7/1/2019 - 6/30/2020
Wage and Supplemental Rate Per Hour: 75% of Journeyman's rate

Tile Layer - Setter - Fifth 750 Hours

Effective Period: 7/1/2019 - 6/30/2020
Wage and Supplemental Rate Per Hour: 85% of Journeyman's rate

Tile Layer - Setter - Sixth 750 Hours

Effective Period: 7/1/2019 - 6/30/2020
Wage and Supplemental Rate Per Hour: 95% of Journeyman's rate

(Local #7)

TIMBERPERSON

(Ratio of Apprentice to Journeyman: 1 to 1, 1 to 6)

Timberperson - First Year

Effective Period: 7/1/2019 - 6/30/2020
Wage Rate Per Hour: 40% of Journeyman's rate
Supplemental Rate Per Hour: \$33.76

Timberperson - Second Year

Effective Period: 7/1/2019 - 6/30/2020

OFFICE OF THE COMPTROLLER, CITY OF NEW YORK
CONSTRUCTION APPRENTICE PREVAILING WAGE SCHEDULE

Wage Rate Per Hour: 50% of Journeyman's rate
Supplemental Rate Per Hour: \$33.76

Timberperson - Third Year

Effective Period: 7/1/2019 - 6/30/2020
Wage Rate Per Hour: 65% of Journeyman's rate
Supplemental Rate Per Hour: \$33.76

Timberperson - Fourth Year

Effective Period: 7/1/2019 - 6/30/2020
Wage Rate Per Hour: 80% of Journeyman's rate
Supplemental Rate Per Hour: \$33.76

(Local #1536)



Leonard A. Mancusi
SENIOR ASSISTANT COMPTROLLER

THE CITY OF NEW YORK
OFFICE OF THE COMPTROLLER
1 CENTRE STREET ROOM 1120
NEW YORK, N.Y. 10007-2341

TELEPHONE: (212) 680-3822
FAX NUMBER: (212) 689-8499

ALAN G. HEVESI
COMPTROLLER

MEMORANDUM

November 6, 2000

To: Agency Chief Contracting Officers

From: Leonard A. Mancusi

Re: Security at Construction Sites

Prior to the enactment of Administrative Code §6-109, security guards on construction sites were not subject to prevailing wages. Security guards under the New York State labor law are covered under §230 which provides that prevailing wages are to be paid for security guards in existing buildings. §6-109 of the Administrative Code which was enacted in 1996 closed this loophole by including all security guards working pursuant to a city contract as a prevailing wage trade.

Although some construction contract boilerplate language has been amended to include §6-109, sub-contractors performing security services have advised us that they were not aware of this provision and, since traditionally, security guards were not a covered trade on construction sites, and they were not advised by a prime contractor that they would have to pay prevailing wages, they have not been doing so.

To avoid the possibility of issuing stop payments against prime contractors for the failure of their security service sub-contractors to pay

prevailing wages, we suggest that you write to all your existing security guard sub-contractors and their primes and in the future, upon approval of a security guard sub-contractor, advise the contractors of their obligation to pay prevailing wages under §6-109 of the Administrative Code.

As always, your cooperation is appreciated.

LAM:er
ACCO.SECURITY AT SITES

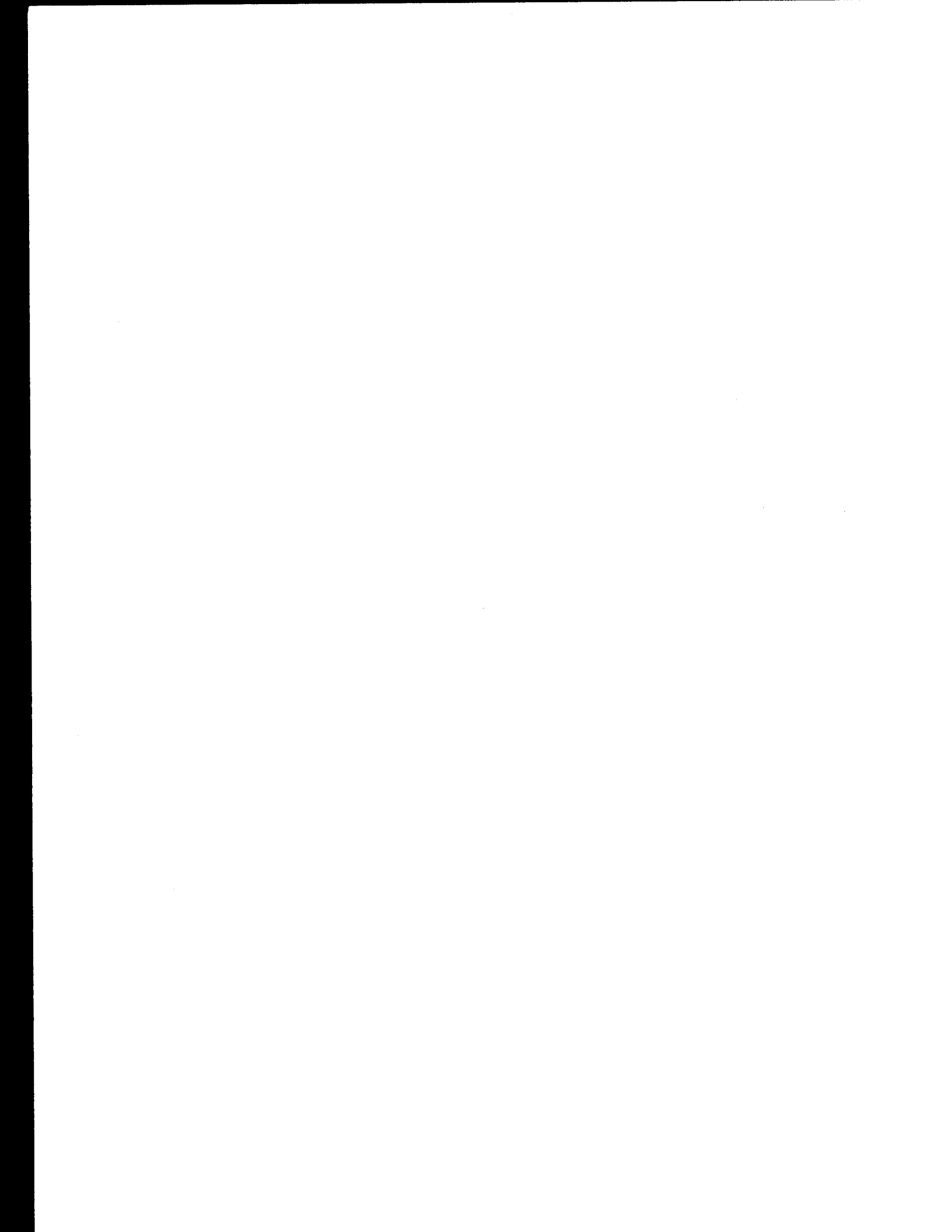



**Department of
Design and
Construction**

**DIVISION OF INFRASTRUCTURE
BUREAU OF DESIGN**

VOLUME 2 OF 3

Contractor

Dated _____, 20__

**APPROVED AS TO FORM
CERTIFIED AS TO LEGAL AUTHORITY**

Acting Corporation Counsel

Dated _____, 20__



**Department of
Design and
Construction**

**THE CITY OF NEW YORK
DEPARTMENT OF DESIGN AND
CONSTRUCTION
DIVISION OF INFRASTRUCTURE
30-30 THOMSON AVENUE
LONG ISLAND CITY, NY, 11101
TEL: 718.391.1000
WEB: www.nyc.gov/ddc**

TO BE FILLED IN BY THE BIDDER:

BIDDER'S NAME:

**BID SECURITY (CIRCLE ONE):
BID BOND / CERTIFIED CHECK**

**NUMBER OF ADDENDUMS RECEIVED
AND ATTACHED TO BID:
____ ADDENDUMS**

DDC CLIENT AGENCY:
**THE DEPARTMENT OF
ENVIRONMENTAL PROTECTION**

PREPARED BY:
**IN-HOUSE DESIGN
DATE PREPARED:
09/12/2019**

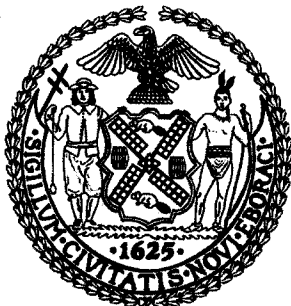

VOLUME 3 OF 3

FOR FURNISHING ALL LABOR AND MATERIALS
NECESSARY AND REQUIRED FOR:

PROJECT ID: SEQBN11

**SCHEDULE A
SPECIFICATIONS AND
REVISIONS TO STANDARD
SPECIFICATIONS**

**RECONSTRUCTION OF EXISTING SEWERS,
NORTH QUEENS**

TOGETHER WITH ALL WORK INCIDENTAL THERETO
**BOROUGH OF QUEENS
CITY OF NEW YORK**



VOLUME 3 OF 3
TABLE OF CONTENTS

<u>SECTION</u>	<u>DESCRIPTION</u>	<u>PAGES</u>
	SPECIFICATIONS AND STANDARDS OF NEW YORK CITY	1 OF 2 AND 2 OF 2
SCHEDULE A	GENERAL CONDITIONS TO CONSTRUCTION CONTRACT	SA-1 to SA-13
R - PAGES	REVISIONS TO STANDARD SPECIFICATIONS	R-1 to R-2
SW - PAGES	SEWER AND WATER MAIN SPECIFICATIONS	SW-1 to SW-29
EP7 – PAGES	GAS COST SHARING (EP-7) STANDARD SPECIFICATIONS	EP7-1 to EP7-28D
U - PAGES	SECTION U 2.0	U-1 to U-16

(NO TEXT ON THIS PAGE)

SPECIFICATIONS AND STANDARDS OF NEW YORK CITY

The following New York City Department of Transportation (NYCDOT) reference documents are available online at: <http://www1.nyc.gov/site/ddc/resources/publications.page> and <https://www1.nyc.gov/html/dot/html/about/dotlibrary.shtml#spec> or for purchase between 9:00 A.M. and 3:00 P.M. Bid Window, at 55 Water St., Ground Floor, NYC, N.Y. 10041. Tel. (212) 839-9435.

1. NYCDOT Standard Highway Specifications, August 1, 2015
2. NYC DOT Standard Details of Construction, July 2010 (Revised March 15, 2016)
3. NYCDOT Division of Street Lighting Specifications
4. NYCDOT Division of Street Lighting Standard Drawings
5. NYCDOT Standard Specifications for Traffic Signals
6. NYCDOT Standard Drawings for Traffic Signals

The following reference documents for New York City Department of Environmental Protection (NYCDEP) are available online at: <http://www1.nyc.gov/site/ddc/resources/publications.page> or for pick up between 8:00 A.M. and 4:00 P.M. at 30-30 Thomson Avenue, 3rd Floor, Division of Infrastructure, Long Island City, N.Y. 11101.

Contact: Mr. Nader Soliman, Tel. (718) 391-1179

1. NYCDEP Standard Sewer and Water Main Specifications, July 1, 2014
2. NYCDEP Instructions for Concrete Specifications, Jan. 92
3. NYCDEP General Specification 11-Concrete, November 1991
4. NYCDEP Sewer Design Standards, (September 2007) Revised August 2018

The following reference documents for New York City Department of Environmental Protection (NYCDEP) are available online at: <https://www1.nyc.gov/site/dep/water/green-infrastructure.page> or for pick up between 8:00 A.M. and 4:00 P.M. at 30-30 Thomson Avenue, 3rd Floor, Division of Infrastructure, Long Island City, N.Y. 11101.

Contact: Mr. Robert Kuhlmann, Tel. (718) 391-2145

1. NYCDEP Water Main Standard Drawings, November 2010
2. Specifications for Trunk Main Work, July 2014
3. Standard Design and Guidelines for Green Infrastructure Practices, latest version, available only online at: <https://www1.nyc.gov/assets/dep/downloads/pdf/water/stormwater/green-infrastructure/green-infrastructure-standard-designs.pdf>

Water main work material specifications are available at the Department of Environmental Protection, 59-17 Junction Boulevard, 3rd Floor Low-Rise Building, Flushing, N.Y. 11373-5108.

Contact: Mr. Tarlock Sahansra, P.E., Tel. (718) 595-5302

E-mail: TSAHANSRA@DEP.NYC.GOV

Standard Specifications and Drawings for New York City Fire Department Communications facilities of New York City are available online at <https://www1.nyc.gov/assets/fdny/downloads/pdf/about/fdny-plant-operations-standard-drawings-specifications.pdf> or for pick up from the FDNY Facilities Management Bureau, Plant Operations Engineering, 316 Sgt. Beers Avenue Cluster 1 Box 16, Fort Totten, N.Y. 11359.

Contact: Mr. Ed Durkin, Tel. (718) 281-3933

Tree Planting Standards of the City of New York Parks & Recreation are available at the following Department of Parks & Recreation website:

<http://www.nycgovparks.org/pagefiles/53/Tree-Planting-Standards.pdf>

SPECIFICATIONS AND STANDARDS OF PRIVATE UTILITIES

The Following reference document for Private Utility Work is available for pick up between 8:30 A.M. and 4:00 P.M. at 30-30 Thomson Avenue, First Floor Bid Procurement Room, L.I.C., N.Y. 11101.

1. CET SPECIFICATIONS AND SKETCHES dated November 2010.

SCHEDULE A**(GENERAL CONDITIONS TO CONSTRUCTION CONTRACT
(INCLUDING GENERAL CONDITIONS RELATED TO ARTICLE 22 – INSURANCE)****PART I. REQUIRED INFORMATION**

<p align="center"><u>INFORMATION FOR BIDDERS SECTION 26 BID SECURITY</u></p> <p><u>The Contractor shall obtain a bid security in the amount indicated to the right.</u></p>	<p>Required provided the TOTAL BID PRICE set forth on the Bid Form is \$1,000,000. or more.</p> <p>Certified Check: 2% of Bid Amount or Bond: 10% of Bid Amount</p>
<p align="center"><u>INFORMATION FOR BIDDERS SECTION 26 PERFORMANCE AND PAYMENT BONDS</u></p> <p><u>The Contractor shall obtain performance and payment bonds in the amount indicated to the right.</u></p>	<p>Required for contracts in the amount of \$1,000,000 or more.</p> <p>Performance Security and Payment Security shall each be in an amount equal to 100% of the Contract Price.</p>
<p align="center"><u>INFORMATION FOR BIDDERS DEPARTMENT OF DESIGN AND CONSTRUCTION SAFETY REQUIREMENTS</u></p> <p>The Contractor shall provide the safety personnel as indicated to the right.</p>	<p><input checked="" type="checkbox"/> Project Safety Representative</p> <p><input type="checkbox"/> Dedicated, full-time Project Safety Manager</p>
<p align="center"><u>CONTRACT ARTICLE 14 DATE FOR SUBSTANTIAL COMPLETION</u></p> <p>The Contractor shall substantially complete the Work in the number of calendar days indicated to the right.</p>	<p>See Page SA-4</p>
<p align="center"><u>CONTRACT ARTICLE 15 LIQUIDATED DAMAGES</u></p> <p>If the Contractor fails to substantially complete the Work within the time fixed for substantial completion plus authorized time extensions or if the Contractor, in the sole determination of the Commissioner, has abandoned the Work, the Contractor shall pay to the City the amount indicated to the right.</p>	<p>See Section C.(1) in the SEWER AND WATER MAIN REVISIONS TO SPECIFICATIONS (SW-PAGES) page SW-7 in volume 3 of 3 of this contract.”</p>
<p align="center"><u>CONTRACT ARTICLE 17. SUB-CONTRACTOR</u></p> <p>The Contractor shall not make subcontracts totaling an amount more than the percentage of the total Contract price indicated to the right.</p>	<p>Not to exceed <u>35</u> % of the Contract price</p>

<p align="center"><u>CONTRACT ARTICLE 21.</u> <u>RETAINAGE</u></p> <p>The Commissioner shall deduct and retain until the substantial completion of the Work the percent value of the Work indicated to the right.</p>	<p align="center"><u>5 %</u> of the value of the Work</p>
<p align="center"><u>CONTRACT ARTICLE 22.</u> <u>(Per Directions Below)</u></p>	<p align="center">See pages SA-5 through SA-12</p>
<p align="center"><u>CONTRACT ARTICLE 24.</u> <u>DEPOSIT GUARANTEE</u></p> <p>As security for the faithful performance of its obligations, the Contractor, upon filing its requisition for payment on Substantial Completion, shall deposit with the Commissioner a sum equal to the percentage of the Contract price indicated to the right.</p>	<p align="center">1% of Contract price</p>
<p align="center"><u>CONTRACT ARTICLE 24.</u> <u>PERIOD OF GUARANTEE</u></p> <p>Periods of maintenance and guarantee other than the period set forth in Article 24.1 are indicated to the right.</p>	<p align="center">Eighteen (18) Months, excluding Trees</p> <p align="center">Twenty-four (24) Months for Tree Planting</p>
<p align="center"><u>CONTRACT ARTICLE 74.</u> <u>STATEMENT OF WORK</u></p> <p>The Contractor shall furnish all labor and materials and perform all Work in strict accordance with the Contract Drawings, Specifications, and all Addenda thereto, as shown in the column to the right.</p>	<p>Addenda, numbered:</p> <p align="center"><u>0</u></p>
<p align="center"><u>CONTRACT ARTICLE 75.</u> <u>COMPENSATION TO BE PAID TO CONTRACTOR</u></p> <p>The City shall pay and the Contractor shall accept in full consideration for the performance of the Contract, subject to additions and deductions as provided herein, the total sum shown in the column to the right, being the amount at which the Contract was awarded to the Contractor at a public letting thereof, based upon the Contractor's bid for the Contract.</p>	<p>Amount for which the Contract was Awarded:</p> <p align="center"><u>seven million five hundred eighty-six thousand forty-seven and seven tenths</u> Dollars</p> <p align="center">(\$ <u>7,586,047.70</u>)</p>
<p align="center"><u>CONTRACT ARTICLE 79.</u> <u>PARTICIPATION BY MINORITY-OWNED AND WOMEN-OWNED BUSINESS ENTERPRISES IN CITY PROCUREMENT</u></p>	<p align="center">See M/WBE Utilization Plan in the Bid Booklet</p>

<p style="text-align: center;"><u>STANDARD HIGHWAY SPECIFICATIONS</u> <u>SECTION 6.40</u> <u>LIQUIDATED DAMAGES FOR ENGINEER'S FIELD OFFICE</u></p> <p>If the Contractor fails to satisfactorily provide the field office and all equipment specified in Section 6.40 - Engineer's Field Office, and/or if a cited deficiency exceed seventy two (72) hours after notice from the Engineer in writing, or is permitted to recur, liquidated damages will be assessed in the amount specified herein for each subsequent calendar day or part thereof that a cited deficiency resulting in nonpayment, as described in Section 6.40.5, is not corrected.</p>	<p>\$ <u>500.00</u> for each calendar day of deficiency</p>
<p style="text-align: center;"><u>STANDARD HIGHWAY SPECIFICATIONS</u> <u>SECTION 6.70</u> <u>LIQUIDATED DAMAGES FOR MAINTENANCE AND PROTECTION OF TRAFFIC</u></p>	<p>\$ <u>250.00</u> for each instance of failure to comply with the Maintenance and Protection of Traffic requirements within three (3) hours after written notice from the Engineer.</p> <p>\$ <u>500.00</u> for each and every hour of failing to open the entire width of roadway to traffic the morning following a night/weekend work operation.</p>
<p style="text-align: center;"><u>STANDARD HIGHWAY SPECIFICATIONS</u> <u>SECTION 7.13</u> <u>LIQUIDATED DAMAGES FOR MAINTENANCE OF SITE</u></p> <p>If the Contractor fails to comply, within three (3) consecutive hours after written notice from the Engineer, with the requirements of Section 7.13 - Maintenance of Site, the Contractor shall pay to the City of New York, until such notice has been complied with or rescinded, the sum specified above per calendar day, for each instance of such failure, as liquidated damages and not as a penalty, for such default.</p>	<p>\$ <u>500.00</u> for each calendar day, for each occurrence</p>

Date for Substantial Completion (Reference: Article 14)

The Contractor shall substantially complete the Work within the Final Contract Duration determined in accordance with the terms and conditions set forth herein.

The Base Contract Duration for this project is 365 consecutive calendar days ("ccds").

The Final Contract Duration shall be the Base Contract Duration when a check mark is indicated before the word "NO", below, and shall be the Base Contract Duration adjusted by the table set forth below when a check mark is indicated before the word "YES", below.

YES NO

When the Final Contract Duration is indicated above to be adjusted by the table below, the table may increase the Base Contract Duration depending on the date of scheduled substantial completion to avoid a scheduled substantial completion of the Work during the winter months. The date of scheduled substantial completion shall be determined by adding the Base Contract Duration to the date specified to commence work in the written Notice to Proceed. The Final Contract Duration shall then be determined as follows:

- (a) Find the row that corresponds to the month of substantial completion based on the Base Contract Duration added to the date specified to commence work in the written Notice to Proceed.
- (b) Find the number of days to be added to the Base Contract Duration in the table below. Add that number of days to the Base Contract Duration to obtain the Final Contract Duration in consecutive calendar days.

Month of Substantial Completion based on the Base Contract Duration	Number of Days of adjustment
January	150
February	120
March	90
April	60
May	30
June	0
July	0
August	0
September	0
October	0
November –December 15	0
December 16 – December 31	180

In addition, should Item No. 9.30, "Storm Water Pollution Prevention," exist in the Contract and the required Storm Water Pollution Prevention Plan (SWPPP) does not conform to NYSDEC's recommended Standards, an additional 60 ccd shall be added to the above Final Contract Duration.

(GENERAL CONDITIONS RELATING TO ARTICLE 22 – INSURANCE)

PART II. TYPES OF INSURANCE, MINIMUM LIMITS AND SPECIAL CONDITIONS

Note: All certificate(s) of insurance submitted pursuant to Contract Article 22.3.3 must be accompanied by a Certification by Broker consistent with Part III below and include the following information:

- For each insurance policy, the name and NAIC number of issuing company, number of policy, and effective dates;
- Policy limits consistent with the requirements listed below;
- Additional insureds or loss payees consistent with the requirements listed below; and
- The number assigned to the Contract by the City (in the “Description of Operations” field).

Insurance indicated by a blackened box (■) or by X in a □ to left will be required under this contract

Types of Insurance (per Article 22 in its entirety, including listed paragraph)	Minimum Limits and Special Conditions
<p>■ Commercial General Liability Art. 22.1.1</p>	<p>The minimum limits shall be \$ <u>3,000,000</u> per occurrence and \$ <u>6,000,000</u> per project aggregate applicable to this Contract.</p> <p>Additional Insureds:</p> <ol style="list-style-type: none"> 1. City of New York, including its officials and employees, with coverage at least as broad as ISO Form CG 20 10 and CG 20 37, 2. All person(s) or organization(s), if any, that Article 22.1.1(b) of the Contract requires to be named as Additional Insured(s), with coverage at least as broad as ISO Form CG 20 26. The Additional Insured endorsement shall either specify the entity’s name, if known, or the entity’s title (e.g., Project Manager), 3. National Grid 4. Consolidated Edison

<ul style="list-style-type: none"> <input checked="" type="checkbox"/> Workers' Compensation Art. 22.1.2 <input checked="" type="checkbox"/> Disability Benefits Insurance Art. 22.1.2 <input checked="" type="checkbox"/> Employers' Liability Art. 22.1.2 <input type="checkbox"/> Jones Act Art. 22.1.3 <input type="checkbox"/> U.S. Longshoremen's and Harbor Workers Compensation Act Art. 22.1.3 	<p>Workers' Compensation, Employers' Liability, and Disability Benefits Insurance: Statutory per New York State law without regard to jurisdiction.</p> <p>Note: The following forms are acceptable: (1) New York State Workers' Compensation Board Form No. C-105.2, (2) State Insurance Fund Form No. U-26.3, (3) New York State Workers' Compensation Board Form No. DB-120.1 and (4) Request for WC/DB Exemption Form No. CE-200. The City will not accept an ACORD form as proof of Workers' Compensation or Disability Insurance.</p> <p>Jones Act and U.S. Longshoremen's and Harbor Workers' Compensation Act: Statutory per U.S. Law.</p> <p><input type="checkbox"/> Additional Requirements:</p> <p>(1) <u>NYCTA "OUTSIDE CONTRACT" INSURANCE REQUIREMENTS: Workers' Compensation Insurance (including Employer's Liability Insurance) with limits of not less than \$2,000,000, which limit may be met by a combination of primary and excess insurance meeting the statutory limits of New York State.</u></p> <p>(2) <u>Two (2) certificates of such insurance shall be furnished to the Director, Risk Management, MTA Risk and Insurance Management Standards, Enforcement and Claims Unit, 2 Broadway, 21st Floor, New York, NY 10004.</u></p>
---	---

<p><input type="checkbox"/> Builders' Risk</p> <p>Art. 22.1.4</p>	<p><input type="checkbox"/> Required: 100% of total bid amount</p> <p><input type="checkbox"/> Required: 100 % of total bid amount for Item(s):</p> <p>Contractor the Named Insured; the City both an Additional Insured and one of the loss payees as its interests may appear.</p> <p>If the Work does not involve construction of a new building or gut renovation work, the Contractor may provide an installation floater in lieu of Builders Risk insurance.</p> <p>Note: Builders Risk Insurance may terminate upon Substantial Completion of the Work in its entirety.</p>
<p><input checked="" type="checkbox"/> Commercial Auto Liability</p> <p>Art. 22.1.5</p>	<p>\$ <u>2,000,000</u> per accident combined single limit</p> <p>If vehicles are used for transporting hazardous materials, the Contractor shall provide pollution liability broadened coverage for covered vehicles (endorsement CA 99 48) as well as proof of MCS 90</p> <p>Additional Insureds:</p> <p>(1) <u>City of New York, including its officials and employees.</u></p>
<p><input type="checkbox"/> Contractors Pollution Liability</p> <p>Art. 22.1.6</p>	<p>\$ <u>5,000,000</u> per occurrence</p> <p>\$ <u>5,000,000</u> aggregate</p> <p>Additional Insureds:</p> <p>1. City of New York, including its officials and employees, and</p> <p>2. _____</p> <p>3. _____</p>

<input type="checkbox"/> Marine Protection and Indemnity Art. 22.1.7(a)	<p>\$ _____ each occurrence \$ _____ aggregate</p> <p>Additional Insureds: 1. City of New York, including its officials and employees, and 2. _____ 3. _____</p>
<input type="checkbox"/> Hull and Machinery Insurance Art. 22.1.7(b)	<p>\$ _____ per occurrence \$ _____ aggregate</p> <p>Additional Insureds: 1. City of New York, including its officials and employees, and 2. _____ 3. _____</p>
<input type="checkbox"/> Marine Pollution Liability Art. 22.1.7(c)	<p>\$ <u>1,000,000</u> per occurrence \$ <u>1,000,000</u> aggregate</p> <p>Additional Insureds: 1. City of New York, including its officials and employees, and 2. _____ 3. _____</p>

[OTHER]
22.1.8

Art.

Railroad Protection Liability Policy

(ISO-RIMA or equivalent form) approved by Permittee covering the work to be performed at the designated site and affording protection for damages arising out of bodily injury or death, physical damage to or destruction of property, including damage to the Insured's own property and conforming to the following:

- Policy Endorsement CG 28 31 - Pollution Exclusion Amendment is required to be endorsed onto the policy when environmental-related work and/or exposures exist.
- Indicate the Name and address of the Contractor to perform the work, the Contract # and the name of the railroad property where the work is being performed and the Agency Permit.
- Evidence of Railroad Protective Liability Insurance, must be provided in the form of the Original Policy. A detailed Insurance Binder (ACORD or Manuscript Form) will be accepted pending issuance of the Original Policy, which must be provided within 30 days of the Binder Approval.

\$ 2,000,000 per occurrence

\$ 6,000,000 annual aggregate

Named Insureds:

1. New York City Transit Authority (NYCTA), the Manhattan and Bronx Surface Transit Operation Authority (MaBSTOA), the Staten Island Rapid Transit Operation Authority (SIRTOA), MTA Capital Construction Co., the Metropolitan Transportation Authority (MTA) including its subsidiaries and affiliates, and the City of New York (as Owner) and all other indemnified parties.

[OTHER]

Art. 22.1.8

 Professional Liability

- A. The Contractor's Professional Engineer shall maintain and submit evidence of Professional Liability Insurance in the minimum amount of \$1,000,000 per claim. The policy or policies shall include an endorsement to cover the liability assumed by the Contractor under this Contract arising out of the negligent performance of professional services or caused by an error, omission or negligent act of the Contractor's Professional Engineer or anyone employed by the Contractor's Professional Engineer.
- B. Claims-made policies will be accepted for Professional Liability Insurance. All such policies shall have an extended reporting period option or automatic coverage of not less than two (2) years. If available as an option, the Contractor's Professional Engineer shall purchase extended reporting period coverage effective on cancellation or termination of such insurance unless a new policy is secured with a retroactive date, including at least the last policy year.

[OTHER]

Art. 22.1.8

 Engineer's Field Office**Section 6.40, Standard Highway Specifications**

Fire insurance, extended coverage and vandalism, malicious mischief and burglary, and theft insurance coverage in the amount of \$40,000

[OTHER]

Art. 22.1.8

 The Following Additional Insurance Must Be Provided:

Umbrella/Excess Liability Insurance - The Contractor shall provide Umbrella/Excess Liability Insurance in the minimum amount of \$10,000,000 per Occurrence and \$10,000,000 in Aggregate. The policy terms and condition should be at least as broad as the underlying policies. The underlying policies should comply with the insurance provision as outlined by the contract. Defense cost should be in addition to the limit of liability. The City of New York, including its officials and employees, should be included as additional insured as respects to the noted project.

Per **Article 22.2.5** of the **Standard Construction Contract**: The Contractor may satisfy its insurance obligations as defined in this Schedule A through primary policies or a combination of primary and excess/umbrella policies, so long as all policies provide the scope of coverage required herein.

SCHEDULE A
(GENERAL CONDITIONS TO CONSTRUCTION CONTRACT)
(GENERAL CONDITIONS RELATING TO ARTICLE 22 – INSURANCE)

PART III. CERTIFICATES OF INSURANCE

All certificates of insurance (except certificates of insurance solely evidencing Workers' Compensation Insurance, Employer's Liability Insurance, and/or Disability Benefits Insurance) must be accompanied by one of the following:

- (1) the Certification by Insurance Broker or Agent on the following page setting forth the required information and signatures;

-- OR --

- (2) copies of all policies as certified by an authorized representative of the issuing insurance carrier that are referenced in such certificate of insurance. If any policy is not available at the time of submission, certified binders may be submitted until such time as the policy is available, at which time a certified copy of the policy shall be submitted.

SCHEDULE A

(GENERAL CONDITIONS TO CONSTRUCTION CONTRACT)

PART IV. ADDRESS OF COMMISSIONER

Wherever reference is made in Article 7 or Article 22 to documents to be sent to the **Commissioner** (e.g., notices, filings, or submissions), such documents shall be sent to the address set forth below or, in the absence of such address, to the **Commissioner's** address as provided elsewhere in this **Contract**.

DDC Director, Insurance Risk Manager

30 – 30 Thomson Avenue, 4th Floor (IDCNY Building)

Long Island City, NY 11101

(NO FURTHER TEXT ON THIS PAGE)

NO TEXT ON THIS PAGE

REVISIONS TO STANDARD SPECIFICATIONS

NOTICE

The Specification Bulletin(s) ("SB(s)") referenced in this Section (R-Pages) may consist of revisions to the following Standard Specifications:

- New York City Department of Transportation ("NYC DOT") Standard Highway Specifications, dated 8/1/2015;
- New York City Department of Environmental Protection ("NYC DEP") Standard Sewer and Water Main Specifications, dated 7/1/2014; and
- NYC DEP Specifications for Trunk Main Work, dated 7/2014.

The SB(s) modify and supersede portions of the applicable Standard Specifications. The provisions contained in this Contract's I-Pages, S-Pages and SW-Pages may further modify the applicable Standard Specifications.

The following SB(s) are included as part of this contract:

- SB 16-001 – REVISIONS TO THE NYC DOT STANDARD HIGHWAY SPECIFICATIONS.
- SB 16-002 – REVISIONS TO THE NYC DEP STANDARD SEWER AND WATER MAIN SPECIFICATIONS.
- SB 17-001 – UV CURED-IN-PLACE-PIPE (CIPP) LINING METHOD
- *SB 17-002 – SUPERSEDED BY SB 18-001*
- SB 17-003 – ENGINEERS FIELD OFFICE
- SB 17-004 – FIRE DEPARTMENT FACILITIES
- SB 17-005 – DIGITAL PHOTOGRAPHS
- SB 17-006 – RECORDS OF SUBSURFACE STRUCTURES
- SB 17-007 – MOBILIZATION
- SB 17-008 – QUALIFICATION CARDS
- SB 17-009 – SALVAGEABLE MATERIALS
- SB 17-010 – MILLED ASPHALTIC CONCRETE AGGREGATE
- SB 17-011 – DETECTABLE WARNING UNIT COLOR

- SB 17-012 – TEMPORARY HOUSE CONNECTION MATERIAL
- SB 18-001 – RODENT AND WATERBUG PEST CONTROL
- SB 18-002 – COLOR SURFACE TREATMENT FOR PAVEMENTS
- SB 18-003 – WATER AND SEWER GENERAL PROVISIONS
- SB 18-004 – CUTTING DUCTILE IRON PIPE
- SB 18-005 – STOCKPILES
- SB 19-001 – RESTORATION OF PAVEMENT SURFACE

The SB(s) are available online at:

<http://www1.nyc.gov/site/ddc/resources/specification-bulletins.page> or for pickup between 8:00 AM and 4:00 PM at 30-30 Thomson Avenue, 3rd Floor, Division of Infrastructure, Long Island City, NY 11101. Contacts:

- Mr. Richard Jones, (718) 391-1417
- Mr. Salman Macktoom, (718) 391-2041

(NO FURTHER TEXT THIS PAGE)

NOTICE

The Standard Sewer And Water Main Specifications of the Department of Environmental Protection (dated July 1, 2014), Sewer Design Standards of the Department of Environmental Protection (dated (September 2007) Revised (August 2018), Water Main Standard Drawings of the Department of Environmental Protection (latest revisions), Specifications For Trunk Main Work of the Department of Environmental Protection (dated July 2014) and the Standard Highway Specifications (Volumes I and II) of the Department of Transportation (dated August 1, 2015) of The City of New York, shall be included as part of the contract documents. These said specifications and standard drawings are hereby revised under the following section headings:

- A. NOTICE TO BIDDERS
- B. REVISIONS TO THE STANDARD HIGHWAY SPECIFICATIONS
- C. REVISIONS TO THE STANDARD SEWER AND WATER MAIN SPECIFICATIONS
- D. REVISIONS TO THE SPECIFICATIONS FOR TRUNK MAIN WORK

(NO TEXT ON THIS PAGE)

A. NOTICE TO BIDDERS

- (1) The Contractor is advised that this contract may include locations in the Bronx and South Queens. At the Commissioner's sole discretion, and as directed in writing by the Commissioner, locations beyond North Queens, specifically locations in South Queens and the Bronx, may be added to this contract in the event that contracts SEQBS11 (South Queens) and SEX0201ZC (the Bronx) are terminated. Only locations within the respective areas covered by these contracts, once terminated, may be added to this contract. The prices for the applicable unit items bid under this project SEQBN11 shall apply to the added locations.
- (2) The Contractor is notified that a Notice To Proceed (NTP) date will be issued for work to commence within twenty-one (21) to thirty (30) days of Contract Registration.
- (3) The Contractor shall furnish, install, maintain and subsequently remove temporary Protective Tree Barriers. Protective Tree Barriers shall be Type B, unless otherwise directed by the Engineer, and shall be constructed and installed as shown on the Protective Tree Barrier sketch in Department Of Transportation, Standard Highway Details Of Construction, Drawing No. H-1046A, as directed by the Engineer, and in accordance with Department of Parks and Recreation requirements.
- (4) The Contractor is notified that Victaulic Style 77 Coupling is no longer acceptable for use in any steel water main work. All reference to Victaulic Style 77 Coupling within the Standard Sewer And Water Main Specifications of the Department of Environmental Protection (dated July 1, 2014), the Water Main Standard Drawings of the Department of Environmental Protection (latest revisions), the Specifications For Trunk Main Work (dated July 2014), and the contract drawings, shall be replaced with Bolted Split-Sleeve Restrained Coupling.
- (5) The Contractor is notified that wherever the Item No. "6.52" and words "flagger", "flagperson" and "flagman" are used in the contract documents and drawings it shall mean the Item No. "6.52 CG" and the words "Crossing Guard", respectively. The Contractor is advised that until the Comptroller of the City of New York sets a prevailing wage rate for crossing guards, there are no prevailing wage rates for crossing guards.
- (6) The Contractor is notified that the fuel cost per gallon used in the formula under **Sub-Article 26.2.8** of the Standard Construction Contract for **Extra Work** will be derived from the fuel price index for the United States East Coast published weekly by the United States Energy Information Administration ("USEIA"), and available on its website at <http://www.eia.gov/petroleum/gasdiesel/>. The USEIA published cost per gallon for the applicable fuel on the East Coast for the week in which the first day of each calendar quarter during the contract term occurs (i.e., January 1st, April 1st, July 1st and September 1st) will be used in the reimbursement formula for all **Extra Work** invoiced that was performed during that calendar quarter. Should the USEIA stop publishing this fuel price index, the fuel cost per gallon will be determined by reference to a substitute index to be agreed upon by the Contractor and the City.
- (7) (A) There is no provision for "ENGINEER'S FIELD OFFICE" in this contract, as per **New York City Department of Transportation (NYCDOT) Standard Highway Specifications Section 6.40 - Engineer's Field Office**.

(B) There is no item for "MOBILIZATION" in this contract, except for Mobilization for dewatering under Item No. DSS008A. The cost for mobilization shall be deemed included in the prices bid for all contract items of work.
- (8) The Project Sign as per **New York City Department of Transportation (NYCDOT) Standard Highway Specifications Subsection 1.06.46 - Project Sign** will not be required on this contract. However, the Contractor shall be required to provide Temporary Notification Signs in accordance with **New York City Department of Transportation (NYCDOT) Standard Highway Specifications Subsection 1.06.46A - Temporary Notification Signs**.

- (9) The Contractor is responsible for any damage to the existing street and traffic signal equipment, including underground conduits and the safety of both pedestrian and vehicular traffic for the duration of the contract.

Should any conduits, cables or foundations need repair due to the Contractor's negligent operations during construction, all work shall be performed according to NYCDOT Bureau of Traffic's Standard Drawings and Specifications at the sole expense of the Contractor.

It is the Contractor's responsibility to secure an approved electrical contractor to perform all traffic signal work (if any). For list of approved electrical contractors, contact Mr. Michael R. LeFosse of New York City Department of Transportation at (718) 786-2236.

- (10) The Contractor will be required to prepare and submit "**As Built**" sewer record drawings to the Engineer for approval, at the completion of each installation. Drawings submitted at the completion of the entire contract after all installations shall not be accepted. Approved "**As Built**" drawings shall be delivered to the Department of Environmental Protection, Chief of Emergency Construction, 59-17 Junction Boulevard, 6th Floor - High Rise, Corona, New York, 11368, Tel. No. (718) 227-1868. The following guideline is provided for the preparation of "**As Built**" sewer record drawings:

(A) Drawings shall be prepared for each individual unrelated location. The drawings shall be submitted in CADD format on CD's along with a plotted Mylar for each location drawing. The drawings on CD's and the plotted Mylar's shall be legal size (8-1/2" x 14"). The Mylar shall be 3-mil in thickness.

(B) The "**As Built**" drawings shall conform to Department of Environmental Protection (DEP) Emergency Construction Drawings (ECD). A sample copy of the ECD may be obtained at the above office together with DEP guidelines. These DEP guidelines are summarized below:

- (1) Drawings shall consist of the same legend and layout of title boxes shown on the sample ECD drawing.
- (2) Drawings shall consist of a location plan view on one sheet. The location plan view shall be drawn Not-To-Scale.
- (3) Drawings shall contain a note making reference to the datum used. (Datum used shall be that of the Borough where the sewer is located.)
- (4) Each plotted Mylar drawing shall contain the signature and stamp of the Contractor's NYS Professional Engineer/Registered Architect.
- (5) The location plan view shall include:
 - (a) street name and two (2) crossing streets or distance from;
 - (b) north arrow;
 - (c) property lines and widths;
 - (d) curb lines and widths;
 - (e) sewers, manholes, catch basins, connections (No horizontal bends allowed on sewer lines);
 - (f) sewer sizes, materials (ESVP, RCP, DIP, etc.), and types (New, Existing, Sanitary, Storm, Combined, etc.);
 - (g) sewer length (between centerlines of manholes);
 - (h) sewer flow direction;
 - (i) offsets of sewer lines or extensions from property lines (not curb lines);
 - (j) foundations (concrete cradle, stone ballast, piles, etc.);
 - (k) manholes types (Precast, Concrete, Brick, A-1, A-2, etc.);
 - (l) manhole elevations (both rim and invert);
 - (m) manhole stationing along installed sewers;
 - (n) catch basins types (Type 1, Type 2, etc.);
 - (o) catch basin connections;
 - (p) show actual number of manholes and catch basins;
 - (q) house connection spurs (stations and locations);

- (r) address of house connections (new connections and reconnections);
 - (s) house connection information at curb (station, length, depth and offset from the curb);
 - (t) details of non-standard structures or appurtenances constructed;
 - (u) location of all existing and installed offset distances from property lines;
 - (v) for shotcreted sewers (thickness and reinforcement of shotcreting); and
 - (w) all appropriate notes.
- (6) Examples of notes that can be used are as follows:
- (a) Unless otherwise noted, all house connections are 6" ESVP;
 - (b) Unless otherwise noted, all catch basins are Standard Type 1;
 - (c) Unless otherwise noted, all new curb connections are at a depth of approximately 8-feet at the curb and are 2-feet inside the curb line;
 - (d) Unless otherwise noted, all built manholes are brick;
 - (e) Unless otherwise noted, all catch basin connections are 12" DIP on crushed stone;
 - (f) Unless otherwise noted, all ESVP sewers are installed on 6" concrete cradle;
 - (g) Pipe lengths are measured from inside face of manhole to inside face of manhole.

(C) The cost of preparing and submitting "As Built" approved drawings shall be deemed included in the prices bid for all scheduled bid items in the contract. No separate or additional payment will be made for this work.

- (11) At all locations where the Engineer determines that the existing subgrade material has an unsatisfactory soil bearing capacities, the Contractor shall excavate below subgrade to the depth required to remove the unsatisfactory soil (maximum twenty-five (25) foot depth below subgrade), and shall backfilled to subgrade with stone ballast as described in Section 70.71. Payment for this work shall be made under Item No. 73.31AE2 - ADDITIONAL EARTH EXCAVATION INCLUDING TEST PITS (OVER 12' TO 16' DEPTH),

Item No. 73.31AE3 - ADDITIONAL EARTH EXCAVATION INCLUDING TEST PITS (OVER 16' TO 20' DEPTH),

Item No. 73.31AE4 - ADDITIONAL EARTH EXCAVATION INCLUDING TEST PITS (OVER 20' TO 24' DEPTH),

Item No. 73.31AE5 - ADDITIONAL EARTH EXCAVATION INCLUDING TEST PITS (OVER 24' DEPTH);

and Item No. 70.71SB - STONE BALLAST.

The cost for any additional sheeting and bracing required for excavating below subgrade shall be deemed included in the price bid for Items No. 73.31AE2 - ADDITIONAL EARTH EXCAVATION INCLUDING TEST PITS (OVER 12' TO 16' DEPTH),

Item No. 73.31AE3 - ADDITIONAL EARTH EXCAVATION INCLUDING TEST PITS (OVER 16' TO 20' DEPTH),

Item No. 73.31AE4 - ADDITIONAL EARTH EXCAVATION INCLUDING TEST PITS (OVER 20' TO 24' DEPTH),

Item No. 73.31AE5 - ADDITIONAL EARTH EXCAVATION INCLUDING TEST PITS (OVER 24' DEPTH).

The Sheeting design shall be submitted to Department of Environmental Protection.

- (12) For Specified Length (Spot Repair) Of Existing Catch Basin Connection Reconstruction Work
Ordered Performed: The contract prices for Item No. 52.11D12C - 12" DUCTILE IRON PIPE BASIN
CONNECTION (FOR CHUTE CONNECTION WORK ONLY),

Item No. 52.11V12- 12" EXTRA STRENGTH VIRTIFIED PIPE BASIN CONNECTION,

Item No. 52.11V12C - 12" EXTRA STRENGTH VITRIFIED PIPE BASIN CONNECTION (CHUTE CONNECTION WORK ONLY) shall be the unit price bid per linear foot for each size and class of catch basin connection pipe constructed to all specified lengths (spot repair) and shall cover the cost of all labor, materials, equipment, samples, tests and insurance required and necessary to construct the catch basin connections of the sizes and to the lines and grades shown, specified, or ordered, including the earth excavation of all materials of whatever nature encountered (See Section 40.03 - Earth Excavation); concrete cradles; crushed stone bedding and encasements; all sheeting and bracing; pumping; fluming; bridging; breaking down and filling in of abandoned catch basins and catch basin connections together with their foundations, including bulkheading at both ends; cored openings for connections to structures; connections; backfilling; cleaning up; support and maintenance of existing City structures that are encountered during excavation (including fences, copings, vaults, light poles, etc.), all in accordance with the plans, specifications (See Section 52.11) and standards and as directed by the Engineer.

- (13) The Contractor shall exercise extreme caution and take all necessary precautions in placing sheeting and excavating to prevent any damage to the existing NYC TRANSIT'S subway structures and its appurtenances during construction work throughout the project area. The Contractor shall take full responsibility to protect the said NYC TRANSIT'S subway structures and its appurtenances and any damage caused by the Contractor's operations shall be made good by the Contractor to the satisfaction of the Engineer at no additional cost to the City.
- (14) The Contractor shall submit shop drawings to NYC Transit Authority showing all the details and methods of construction, such as, sheeting and bracing, including the Contractor's procedure and sequence of construction, supporting and/or protection of the existing TA's structures and its appurtenances, with necessary design calculations for approval prior to starting of the construction. The design shall be made by a New York State Licensed Professional Engineer skilled in this type of construction and as further evidenced by the imprint of Professional Engineer's seal and signature on all drawings. The cost of this work shall be deemed included in the price bid for all items of work under this contract.

(NO FURTHER TEXT ON THIS PAGE)

B. REVISIONS TO THE STANDARD HIGHWAY SPECIFICATIONS

- (1) **Refer** to Standard Highway Specifications Volume II (August 1, 2015), Page 553:
Add the following new **Section 9.29**:

SECTION 9.29**ALLOWANCE FOR RAILROAD FACILITIES INCLUDING INSURANCE****AND FORCE ACCOUNT (ALL TYPES)****9.29.1. DESCRIPTION.**

Under this item the Contractor must negotiate with the railroad to obtain a permit to enter railroad property, determine the scope and cost of flaggers/spotters and all associated railroad work, and submit a deposit to the railroad to cover the railroad's miscellaneous costs associated with this contract and all required insurances.

9.29.2. MATERIALS.

(Not applicable)

9.29.3. CONSTRUCTION DETAILS.

Prior to the Contractor providing any services under this Section, the Engineer will provide written direction to the Contractor. The written direction will include:

- The name and contact information of the railroad;
- Additional Insurance requirements;
- Special railroad requirements and provisions;
- Scope and area of work where railroad coordination is required.

When directed by the Engineer, the Contractor must negotiate with the railroad to obtain a permit to enter railroad property, comply with all relevant railroad requirements, and provide a payment fund to the railroad for all miscellaneous expenses incurred by the railroad due to the contractor entering the railroad property. These expenses include the costs incurred by the railroad to provide flaggers, spotters, engineering services (plan review/comments), accounting services (cost work-up and negotiations), construction inspection, or any other labor, material or equipment necessary to provide a safe environment to both the contractor and the railroad. The right-of-entry permit must be obtained prior to commencement of any work within the boundaries of the railroad. The railroad will not provide any services necessitated by the Contractor's operations until the permit is obtained.

This allowance must take care of all the railroad insurances as directed by the Engineer.

9.29.4. METHOD OF MEASUREMENT.

The fixed price lump sum shown in the Bid Schedule for this item shall be included in the total bid price; however, actual payment to the Contractor will be based on the actual invoices submitted by the Contractor in connection with the railroad works as described above.

9.29.5. BASIS OF PAYMENT.

The fixed sum must be considered the price bid for this item. The fixed sum is not to be altered in any manner by the bidder. Should the amount shown be altered, the new figures will be disregarded and the original price will be used to determine the total amount bid for the contract.

The fixed sum payment made under this item will be equal to the sum of all invoices submitted by the Contractor as proof of work performed for this item, as approved by the Engineer.

The "fixed sum" amount is included in the bid solely to ensure that sufficient monies will be available to pay the Contractor for this work, which may be more or less than the fixed sum amount.

The unit price will cover the cost of all labor, materials, equipment, insurance, and incidentals necessary to complete the work under this section in accordance with the Contract Drawings, the specifications and the directions of the Engineer.

Payment will be made under:

Item No.	Item	Pay Unit
9.29	ALLOWANCE FOR RAILROAD FACILITIES INCLUDING INSURANCE AND FORCE ACCOUNT (ALL TYPES)	F.S.

C. REVISIONS TO THE STANDARD SEWER AND WATER MAIN SPECIFICATIONS

- (1) **Refer** to Contract Book, Volume 2 of 3, Standard Construction Contract, **Article 15 - Liquidated Damages**:
Delete this article in its entirety:
Substitute the following new **Article 15**:

ARTICLE 15 - LIQUIDATED DAMAGES

- 15.1 In the event the Contractor fails to complete the Initial Services, as set forth in **Division VIII, Section DSS-4 - Issuance of Work Orders**, within the Initial Response Time, as set forth in Paragraph 15.2 below, the Contractor shall pay to the City the sum(s) set forth below, for each and every specified period of delay in completing the Initial Services. Due to the difficulty in accurately ascertaining the loss the City will suffer by reason of delay in completion of the Initial Services hereunder, the sum(s) set forth below are hereby fixed and agreed to as the liquidated damages that the City will suffer by reason of such delay, and not as a penalty. Liquidated damages will be assessed on a cumulative basis. This article shall also apply to the Contractor if it is defaulted pursuant to CHAPTER X, Page-69 of STANDARD CONSTRUCTION CONTRACT, VOLUME 2 OF 3. Neither the failure to assess liquidated damages nor the granting of any time extension shall operate as a waiver or release of any claim the City may have against the Contractor for either actual or liquidated damages.

Delay Beyond Initial Response Time	Amount of Liquidated Damages
(a) First one (1) hour period after Initial Response Time	\$1,000
(b) First six (6) hour period after the end of the time frame set forth in (a)	\$2,000
(c) Second and all subsequent six (6) hour periods after the end of the time frame set forth in (b)	\$3,000

- 15.2 The Initial Response Time shall mean the period of time within which the Contractor must complete the Initial Services set forth in **Division VIII, Section DSS-4 - Issuance of Work Orders**. The Initial Response Time shall be specified in the Notice provided to the Contractor in accordance with such section. The Initial Response Time shall commence at the time the Notice is transmitted to the Contractor by fax.
- 15.3 Liquidated damages received hereunder are not intended to be nor shall they be treated as either a partial or full waiver or discharge of the City's right to indemnification, or the Contractor's obligation to indemnify the City, or to any other remedy provided for in this Contract or by Law.
- 15.4 The Commissioner may deduct and retain out of the monies which may become due hereunder, the amount of any such liquidated damages; and in case the amount which may become due hereunder shall be less than the amount of liquidated damages suffered by the City, the Contractor shall be liable to pay the difference.

- (2) **Refer** to **Subsection 10.15 - Notice To Utility Companies, Etc., To Remove Structures Occupying Place Of Sewers, Water Mains Or Appurtenances**, Page I-11:
Add the following to **Subsection 10.15**:

(1) CONSOLIDATED EDISON COMPANY OF NEW YORK (CON EDISON)

There are CON EDISON facilities in the areas of reconstruction. The existing systems are comprised of underground ducts, service boxes, manholes, street lighting, utility poles, underground transformer vaults, etc. The Contractor shall notify CON EDISON within the initial response time specified at time of notification of the work order at each ordered location by contacting Mr. Robert Mata, Section Manager Contract Administration and Inspection (Brooklyn), 118-29 Queens Boulevard, Room B206, Forest Hills, NY 11375, at (718) 275-2935.

(2) NATIONAL GRID

There are NATIONAL GRID facilities in the area of construction. The Contractor shall notify NATIONAL GRID at least seventy-two (72) hours prior to the start of construction by contacting Mr. Neville Jacobs Jr. at (718) 963-5612.

(3) VERIZON

There are VERIZON facilities in the areas of reconstruction. The Contractor shall notify VERIZON within the initial response time specified at time of notification of the work order at each ordered location by contacting Mr. Ed Palmer, (Brooklyn) at (718) 977-8138.

(4) TIME WARNER CABLE OF NEW YORK AND CABLEVISION

There are TIME WARNER CABLE and CABLEVISION facilities in the areas of reconstruction. The Contractor shall notify TIME WARNER CABLE and CABLEVISION within the initial response time specified at time of notification of the work order at each ordered location by contacting Mr. Paul Fucci, V.P., Technical Operations at (718) 888-4250 or Ed Vomero at (718) 888-4232.

- (3) **Refer** to **Subsection 10.21 - Contractor To Notify City Departments**, Page I-13:
Add the following to **Subsection 10.21**:

(I) N.Y.C. D.E.P., BUREAU OF WATER AND SEWERS OPERATIONS

The Contractor shall notify Mr. Peter Gordon, P.E., Chief, Linear Capital Program Management Division at the Department of Environmental Protection, at (718)-595-4347, 59-17 Junction Blvd., 3rd floor low rise, Corona N.Y. 11368, at least thirty (30) days prior to the start of construction.

(II) NEW YORK CITY FIRE DEPARTMENT

The Contractor shall notify the Bureau of Fire Communications at least thirty (30) days prior to the start of construction by contacting Mr. Ed Durkin at (718) 281-3933 or (718) 624-3752.

(III) N.Y.C. DEPARTMENT OF TRANSPORTATION

The Contractor shall notify Mr. Michael LeFosse/Ghanshyam Patel - Signal/Street Lighting Operations, 34-02 Queens Blvd., Long Island City, N.Y. 11101 at (212) 839-3350, at least seventy-two (72) hours prior to the start of construction.

(IV) N.Y.C. DEPARTMENT OF PARKS AND RECREATION

The Contractor shall notify the Parks Department at least seventy-two (72) hours prior to the start of construction by contacting Mr. Jason Conheaney at (718) 965-7740.

(V) N.Y.C. TRANSIT AUTHORITY

- (a) The Contractor is advised that bus routes as well as bus stops, within the scope of this project may be affected during construction operations. The Contractor shall notify the Transit Authority at least two (2) weeks prior to the start of construction, in order to make the necessary arrangements as required under the NYC TRANSIT GENERAL NOTES included in **Section 10.25, paragraph (A)**.

Arrangements shall be made through:

Ms. Sarah Wyss
 Director Of Short Range, Bus Service Planning (SRB)
 New York City Transit
 2 Broadway, 17th Floor
 New York, N.Y. 10004
 Telephone No. (646) 252-5517
sarah.wyss@nyct.com

(4) Refer to Subsection 10.24, DAMAGED WATER SERVICE PIPES TO BE REPAIRED BY A LICENSED PLUMBER:

Add the following to Subsection 10.24:

If the damaged or cut water service pipe is lead, galvanized steel, or galvanized iron, the service pipe must not be partially replaced, but fully replaced from the main to the house control valve. If the service pipe was damaged, cut, or otherwise interrupted due to the Contractor's actions or means & methods (including selection of shoring systems), the water service pipe will be replaced at the Contractor's own cost.

(5) Refer to Subsection 10.25 - Contractor To Carry Out Agreement Between City And Railroad Company Or Property Owner(s), Page I-14:

Add the following to Subsection 10.25:

(A) NYC TRANSIT GENERAL NOTES

- (1) The NYC Transit (NYCT) reserves the right to place inspectors, flagmen or other personnel in the subway structures during construction of the project linked by a telephone system, if deemed necessary, to observe the effects of the construction on the transit facilities. It is expected that such personnel will be necessary when the construction comes within twenty-five (25) feet of the subway structure. However, NYCT further reserves the right to place such personnel whenever, in its opinion, the project conditions warrant such placement, regardless of distance. The cost of such personnel, telephone installation and any re-routes, diversions of service, work trains, etc., made necessary by the project, will be paid for directly to the Transit Authority by the City, at no cost to the Contractor.
- (2) All rock excavation adjacent to the transit structure is to be channel drilled two (2) feet below subgrade.
- (3) If top of rock is found below subway structure, the subway structure must be underpinned in accordance with drawings to be submitted to NYCT for approval.

- (4) If rock is soft or seamy, lateral supports must be provided below the subway structure in accordance with drawings to be submitted to NYCT for approval.
- (5) Blasting will be permitted only with light charges subject to the approval of NYCT's Engineer and in accordance with the regulations of the Fire Department. The Contractor shall provide a detailed monitoring plan, providing for measurements of both particle velocity and displacements at critical locations of the NYCT structure. The monitoring plan shall include threshold and upset levels of both particle velocity and settlement together with an action plan for their implementation. The Contractor shall secure an approved seismologist to install and operate suitable velocity gauges to continuously monitor particle velocity and an independent licensed surveyor to monitor displacements. The threshold maximum particle velocity above ambient caused by the blasting will be 0.5 inch per second. Values exceeding this level will be reviewed and evaluated by NYCT's Engineer. In no case will particle velocities exceed the upset level of 2.0 inches per second.
- (6) Before placing concrete, the subgrade of the foundations in the vicinity of the subway structure is to be inspected and approved by NYCT's Engineer.
- (7) If any portion of the subway structure or finish is damaged as a result of the Contractor's operations, it shall be repaired or replaced with the same materials in place, subject to the approval of NYCT's Engineer and at the Contractor's own expense.
- (8) Excavation embankments are to be shored and braced. Drawings indicating a suggested method of construction are to be submitted to NYCT for approval in conjunction with the project's contract drawings. In case of excavation undermining the subway structure, underpinning may be required. Drawings for underpinning are to be submitted to NYCT for approval.
- (9) Temporary shoring may be placed in direct contact with NYCT structures only if the NYCT structure is shown to be able to support all anticipated loads that can be transferred through the temporary structures without damaging the existing structure. At the completion of the project, these temporary shoring and bracing systems are to be removed or cut-off as approved by NYCT.
- (10) When piles are to be driven adjacent to the subway structure, boring data, pile layouts, specifications and installation procedures are to be submitted to NYCT for approval. Velocity meters are to be installed in the subway tunnel at critical locations to monitor induced vibrations. Induced displacements along the tunnel structure and track invert are to be monitored during driving. The threshold maximum particle velocity above ambient caused by the driving will be 0.5 inch per second. Values exceeding this level will be reviewed and evaluated by NYCT's Engineer. In no case will particle velocities exceed the upset level of 2.0 inches per second.
- (11) No piles are permitted to be installed by any method within three (3) feet of subway structure measured from the edge of the pile or casing to the wall. Closed-end piles will not be permitted to be driven within ten (10) feet of the subway structure.
- (12) All piles are to be placed within a preaugered cased hole to the influence line. The casing shall be cleaned without disturbing the soil outside the casing and the pile placed within the casing for installation. The piles may then be driven beyond the influence line within the casing.
- (13) The influence line shall start at the bottom of the subway structure and sidewall and extend at a 1:1 slope. For piles installed within ten (10) feet of the subway structure the casing shall be extended up to the bottom of the subway structure.
- (14) At the completion of pile installation, the space between the pile and the casing is to be filled with either clean sand or grout. If the casing is to be removed, the filling must be completed prior to removal of the casing.

- (15) All piles are to be driven a minimum of ten (10) feet below the intersection of the pile centerline and the influence line of the subway structure.
- (16) The use of "down-the-hole-hammers" for installation of piles through overburden and fill will be permitted only to remove boulders. It will not be permitted as a matter of course to advance the hole. Their use to construct rock sockets will not be allowed within five (5) feet of the NYCT structure.
- (17) Vibratory hammers will not be permitted within seventy-five (75) feet of subway structures. Hoerams will not be permitted within twenty-five (25) feet of subway structures.
- (18) Dynamic compaction methods using dropped heavy weights cannot be conducted within one thousand (1,000) feet of any NYCT structure unless it is shown that induced settlements and vibrations will not damage these structures. A suitable monitoring plan including settlement and vibration measurements must be approved by NYCT's Engineer for all such operations within these distances.
- (19) There shall be no machine excavation within three (3) feet of NYCT structures, power duct lines, or any other facilities until they have been carefully exposed by hand excavation.
- (20) All dewatering operations conducted within five hundred (500) feet of the NYCT structure must be performed in accordance with drawings and procedures submitted to NYCT for approval. The distance from the structure to the dewatering operation can be reduced provided that soil conditions at the site indicate that the radius of influence of the dewatering is less than five hundred (500) feet. For dewatering within the radius of influence, the dewatering program must be shown to have negligible influence on settlements of the NYCT structure.
- (21) Subway entrances (ventilators, etc.) are to be underpinned or shored and braced if directed by NYCT's Engineer.
- (22) NYCT, at its discretion, reserves the right to require the project to close or maintain and protect existing subway entrances, ventilators, etc. adjacent to the project during construction. Such construction may include underpinning, shoring, bracing and erection of suitable barricades and/or canopies and shields. Such protection shall be in accordance with drawings submitted to NYCT for approval.
- (23) If shields are to be installed to protect NYCT facilities and/or the public, plans showing the location, type and method of attachment to the transit structure must be submitted to NYCT for approval.
- (24) All lumber and plywood used for protection of subway facilities must be fire retardant.
- (25) Subway emergency exits must be kept clear at all times.
- (26) In excavation over or near the subway roof, special care shall be exercised so that the thin concrete protection of the subway waterproofing is not damaged.
- (27) Burning of, welding to or drilling through existing steel structures will not be permitted except as shown on drawings approved by NYCT.
- (28) Horizontal and vertical control survey data of the existing NYCT structure is to be taken by a Licensed Land Surveyor to monitor any movements that occur during construction and to show that the induced movements are within allowables provided and approved by NYCT's Engineer. If any movements exceed allowables, remediation as approved by NYCT shall be performed.

(29) Bus routes affected by the project will or may require bus diversions.

When impacting any bus stop, Special Operations must be notified two (2) weeks in advance.

(30) Duct lines must be maintained and protected during construction. Any interference with duct lines should be reported to NYCT inspector. When a duct line containing cables is to be removed, or when masonry adjacent thereto is to be removed, penetrated, or drilled, the work shall be done with hand labor entirely, using hammer and chisel. Jackhammers, bull points or other power equipment shall not be used.

(31) Where manholes are encountered:

- (a) They shall be protected and raised or lowered as required, to match the new street grade.
- (b) If manhole covers are raised or lowered, protect cables in manhole by wood sheeting of two (2) inches nominal thickness.
- (c) Prior to the start of construction operations affecting manholes and duct lines, seven (7) days notice must be given to Mr. John Malvasio, P.E., Director, Department of Maintenance-Of-Way, at (718) 694-1358.

(32) Construction work done near vent gratings and hatches shall be as follows:

- (a) Unless approved by the NYCT's Engineer, all vent gratings and hatches should remain outside the construction site, separated by a construction fence. Protective shields must be provided over vent gratings as required by NYCT's Engineer.
- (b) No building material, vehicles or construction equipment is to be stored or run over vent, gratings, hatches or emergency exits.
- (c) Details of sidewalk reconstruction around vent gratings, hatches and emergency exits are to be submitted to NYCT for approval.

(33) Tractors, cranes, excavators, etc. used in the vicinity of the elevated structures shall be isolated from the ground. Since the elevated structure is used as a negative return path, with a consequent potential between it and the ground, any contact between the structure and grounded equipment could result in burning of the steel.

(34) Temporary construction sheds, barricades or plywood partitions must be a minimum of five (5) feet from edge of finished platform.

(35) Station Areas or Stairway/Entrance closings: The general requirements for Station Areas or Stairway/Entrance closings are as follows:

- (a) Only one (1) stairway at each station will be permitted to be closed at the same time. Approvals for closing any stairway must be obtained from the Division of Station Operations at least three (3) weeks in advance.
- (b) Mr. Ashok Patel, Director, Office of Station Programs; Telephone (718) 694-1695 of the Division of Stations must be notified one (1) week prior to the actual closing and reopening of the entrance.
- (c) Ample signage must be supplied and posted at least one (1) week in advance, advising the public of the proposed subway stair closing.
- (d) The street entrance stairway should not be closed unless manpower and materials are available to commence work on dates permitted.
- (e) Once the closing is effected construction signs must be placed at appropriate locations on the barricades at the street and mezzanine levels, stating the Contractor's name, 24-hour emergency telephone number, contract number, the duration of the closing, direction to an alternate entrance/exit, and an apology for the inconvenience to our customers.
- (f) Existing station signage must be adjusted to reflect any changes in access/egress.
- (g) Barricades are to be painted and kept graffiti free at all times. The Contractor must maintain the barricaded area clean of all debris.

- (h) All materials are to be properly stored and secured away from passenger traffic.
 - (i) The Contractor must remove all waste material and barricades from all station areas when construction is completed.
 - (j) Inspection of the area under construction by authorized Station Department employees shall not be inhibited.
 - (k) If street lights on the sidewalks are affected, temporary lights shall be provided.
- (36) If new concrete construction is joined to existing concrete, dowels and keyways are to be used in accordance with NYCT Standards.
- (37) If the project involves construction or alteration of a subway facility on private property, the property owners will be required to enter into an agreement with NYCT pertaining to all work affecting the transit facilities and clearly defining limits and responsibility for maintenance and liability.
- (38) Wherever a new sidewalk is being placed adjacent to NYCT structures the following will be required:
- (a) The top of the new sidewalk shall be flush with the subway vent gratings, hatches and emergency exits.
 - (b) The slope of the new sidewalk shall be such that the drainage be away from these structures.
 - (c) A one-half (1/2) inch premolded filler shall be installed between the new sidewalk and NYCT structure.
 - (d) Where sidewalk elevations are being changed details of proposed work around NYCT structures are to be submitted for approval.
- (39) Before the start of any work, the Contractor shall make an examination, in the presence of NYCT's Engineer, of the interior and exterior of NYCT subway or other structure adjacent to the proposed work. The person or persons authorized by the Contractor to make these examinations shall be approved by the Engineer. The Contractor shall take all photographs as may be necessary or ordered to indicate the existing condition of NYCT structure. One (1) copy of each photograph, eight (8) inches by ten (10) inches in size, and the negative is to be submitted to Mr. John Malvasio, P.E., Director, Department of Maintenance-Of-Way, 130 Livingston Street, Room 8044D, Brooklyn, New York 11201, Telephone (718) 694-1358 before the start of construction.
- (40) All architectural details (token booths, railings, doors, etc.) are to conform to the latest NYCT Standards. These standards are available at NYCT.
- (41) Standard NYCT insurance clauses are to be made part of the Project's contract drawings. Proof that the necessary insurance is in effect will be required before work can commence.
- (42) At the close of any project involving construction or alterations to transit facilities, one (1) set of vellums or mylars, five (5) sets of 35mm microfilm, and electronic copies complying to microstation.dgn format of "approved as-builts" must be provided to NYCT for its records. For details of specific requirements contact NYCT Outside Projects.
- (43) At least seven (7) working days prior to the start of construction operations, notification must be given to Mr. John Malvasio, P.E., Director, Department of Maintenance-Of-Way, at (718) 694-1358. The Contractor shall provide temporary quarters near the job site for NYCT inspectors containing a desk and telephone.

- (6) **Refer** to **Subsection 10.30 - Contractor To Provide For Traffic**, Page I-15:
Add the following to **Subsection 10.30**:

(1) Traffic Stipulations:

The Contractor shall obtain all permits and traffic requirements from the Office of Construction Mitigation and Coordination (OCMC) prior to the start of work at any ordered location. The Contractors shall contact Nicolas Dagher at 212-839-9637 or John Martin at 212-839-9639, NYC Department of Transportation, Division of Engineering Control, 55 Water Street, 7th Floor, New York, NY 10041.

- (7) **Refer** to **Section 40.06 - Backfilling**, Page IV-18:
Delete from this section, **Subsection 40.06.2(D) - CLEAN FILL** in its entirety:
Substitute the following new **Subsection 40.06.2(D)**:

(D) CLEAN FILL

- (1) Clean fill material for this contract shall be select granular fill ordered in writing by the Engineer where there is a deficiency of acceptable backfill. Select granular fill material shall be required in order to fill voids in the trenches and excavations, (For Sewers Trenches - from a point not less than two (2) feet above the top of sewers to the underside of the pavement as it existed at the start of the work; and, For Water Main Trenches - from a point not less than twelve (12) inches above the top of the barrel of the water main pipe to the underside of the pavement as it existed at the start of the work), caused by the removal of boulders, unsuitable backfill materials, existing sewers and associated sewer structures, and any other underground facilities or structures, and shall be approved clean earth or sand of low silt and clay content (less than eight (8) percent passing No. 200 sieve), free from bricks, blocks, excavated pavement materials and debris, stumps, roots and other organic matter, as well as ashes, oil and other perishable or foreign matter and shall not contain particles larger than one quarter (1/4) inch in diameter.
- (2) This backfill shall be exclusive of the normal backfill required in the trenches and excavations for proposed sewers and associated sewer structures for which payment is included therein. Payment shall be made in accordance with **Subsection 40.06.6**.

- (8) **Refer** to **Section 40.06 - Backfilling**, Page IV-18:
Delete from this section, paragraphs (B) and (C) of **Subsection 40.06.6 - Deficiency Of Backfill Material** in their entirety:
Substitute the following new paragraphs:

- (B) For providing acceptable select granular fill (whether natural or processed) to satisfy the requirements of **Subsection 40.06.2(D)** to fill voids left by the removal of ledge rock payment shall be made under Item No. 70.61RE - ROCK EXCAVATION. The Contractor's attention is directed to **Section 70.61 - Rock Excavation** of the specifications, and that all references to clean fill therein, shall mean select granular fill.
- (C) For providing acceptable select granular fill (whether natural or processed) to satisfy the requirements of **Subsection 40.06.2(D)** payment shall be made under Item No. 73.41AG - ADDITIONAL SELECT GRANULAR BACKFILL. The Contractor's attention is directed to **Section 73.41 - Additional Select Granular Backfill** of the specifications, with the addition that the conditions for use as specified in **Subsection 73.41.1** shall be expanded to include those specified in **Subsection 40.06.2(D)** as amended hereinbefore.

- (9) Refer to Section 70.51 - Excavation Of I In Open Cut, Page VII-37:
Add the following new Subsection 70.51.6:

70.51.6 EXISTING SEWER ENCASED IN CONCRETE

The Contractor is advised that at certain locations, the existing sewer to be removed may be encased in concrete. Where this condition is encountered, the Contractor shall remove the concrete encasement from the site. The quantity, in cubic yards, to be measured for payment shall be determined by taking the total volume of the encased sewer including the cradle portion less the volume of the sewer pipe. Payment shall be made at the unit price bid for Item No. 70.51EO - EXCAVATION OF BOULDERS IN OPEN CUT and shall cover the cost of all labor, materials, plant, equipment and insurance necessary to remove the concrete encasement, together with all work incidental thereto, as directed by the Engineer. The cost of any additional backfilling required to be done in connection with this work shall be deemed included in the unit price bid for Item No. 70.51EO - EXCAVATION OF BOULDERS IN OPEN CUT.

- (10) Refer to Subsection 71.41.4 - Specific Pavement Restoration Provisions, Page VII-67:
Add the following to Subsection 71.41.4:

(E) Specific Pavement Restoration Provisions:

Upon completion, at each and every ordered location, of the reconstructed collapsed or otherwise defective storm, sanitary or combined vitrified clay pipe sewers and the backfill and compaction of all sewer and water main trenches, the Contractor shall permanently restore all roadways, sidewalks and curbs within the ordered limits of the trench width and cutbacks as follows:

(1) Roadway Restoration:

(a) The permanent roadway restoration over the **trench widths and cutbacks only** shall consist of a top course of one and one-half (1-1/2) inches of asphaltic concrete wearing course on a base course of a minimum of four and one-half (4-1/2) inches of binder mixture, or a top course of one and one-half (1-1/2) inches of asphaltic concrete wearing course on a minimum of one and one-half (1-1/2) inches of binder mixture on a base course of a minimum of six (6) inches of high-early strength concrete, to match the existing pavement as directed by the Engineer.

(b) Before the top course is installed, an additional width of asphalt beyond the edge of new base course shall be saw-cut and removed from all edges of trenches to a depth to accommodate the specified top course and the entire area restored. This additional removal shall be in accordance with paragraph (c).

(c) Pavement excavation along with saw cutting of pavements for sewer and water main trenches shall be in accordance with **Section 71.21 - Pavement Excavation** of the Standard Sewer And Water Main Specifications.

(d) At locations requiring the installation of a high-early strength concrete base course, a reflective cracking membrane shall be installed over joints prior to restoration. Additionally, appropriate pavement keys as described below shall be used as required by the Engineer.

(e) Pavement keys **Type B-1** shall be used to insure a desired four (4) inch curb reveal (two and one-half (2-1/2) inch absolute minimum). Pavement key **Type A** shall be used in all intersections. Both keys are to be per Bureau of Highways Operations Specifications and Standard Details of Construction.

(f) The cost of all labor, materials, equipment, samples and tests required and necessary to permanently restore the roadway over the trench width and cutbacks only shall be deemed included in the prices bid for all E.S.V.P. items, all R.C.P. items and all laying ductile iron pipe and

fittings items. No separate or additional payment will be made for any one and one-half (1-1/2) inches of asphaltic concrete wearing course, binder mixture, high-early strength concrete, reflective cracking member, tack coating, full and partial depth saw cutting, excavation of pavements, stripping or milling of existing pavements, etc. required to permanently restore the roadway over the trench width and cutbacks, cost shall be deemed included in the prices of the bid items.

(2) Sidewalk And Curb Restoration:

(a) The permanent sidewalk restoration over the **trench width and cutbacks only** shall consist of 4" concrete sidewalk (unpigmented) outside driveway and 7" concrete sidewalk (unpigmented) inside driveway and pedestrian ramps, as directed by the Engineer. All sidewalks shall be restored in full flag units.

(b) Since all sidewalks shall be restored in full flag units, the cutbacks for sidewalk restoration shall be defined as the distances beyond the edges of the trenches that require removal in order to get to an adjacent undisturbed full flag unit. For the purpose of this contract sidewalk shall be saw-cut, removed and restored in full flag units up to a maximum overall width of ten (10) feet (two (2) full flag units).

(c) The permanent restoration of curbs over the **trench width only** shall consist of concrete curb, straight steel faced concrete curb, depressed steel faced concrete curb and corner steel faced concrete curb, as directed by the Engineer.

(d) The cost of all labor, materials, equipment, samples and tests required and necessary to permanently restore the sidewalk and curb over the trench width and cutbacks only shall be deemed included in the prices bid for all E.S.V.P. items, all R.C.P. items and all laying ductile iron pipe and fittings items. No separate or additional payment will be made for any concrete sidewalk including 6" foundation material, straight and depressed concrete and steel faced concrete curb, corner steel faced concrete curb, full and partial depth saw cutting, excavation of sidewalks and curbs, etc. required to permanently restore the sidewalk and curb over the trench width and cutbacks, cost shall be deemed included in the prices of the bid items.

(3) The cost for all saw cutting of sewer and water trenches and cutbacks, excavation of pavements within limits of sewer and water trenches and cutbacks, tack coating, removal of pavement markings and replacement with thermoplastic reflectorized pavement markings (crosswalks and lane dividers), placement and eradication of temporary roadway markings, stripping or milling of pavement keys and adjustment of city owned castings shall be deemed included in the prices bid for the items specified in paragraph (1)(f) above and paragraph (2)(d) above of this section. No separate or additional payment will be made for this work.

(4) All Sidewalks; Driveways; Curbs; Corner Curbs; Pedestrian Ramps; and Roadway base courses, top courses and wearing courses shall be installed in conformance with the latest Department of Transportation Specifications and Standard Details, except as amended herein.

(5) The Contractor shall exercise caution during the construction operation, so as to prevent damage and/or disturbance to sidewalks, curbs and roadways outside the ordered reconstruction limits of trench width and cutbacks.

(6) All disturbed grass sidewalk areas over the trench width and cutbacks only shall be restored in conformance with the **New York City Department of Transportation (NYCDOT) Standard Highway Specifications Section 4.19 - Sodding**. The cost of all labor, materials, equipment, samples and tests required and necessary to install sod in grass sidewalk areas over the trench width and cutbacks shall be deemed included in the prices bid for the items specified in paragraph (1)(f) above and paragraph (2)(d) above of this section. No separate or additional payment will be made for this work.

(7) Should granite block, asphalt block or brick pavement be encountered over the trench width and cutbacks only, five (5) inches of binder mixture shall be substituted for the blocks and bricks removed. The binder mixture shall be installed on a base course of a minimum of six (6) inch of high-early strength concrete and topped with a top course of one and one-half (1-1/2) inches of asphaltic concrete wearing course on a minimum of one and one-half (1-1/2) inches of binder mixture to match the existing pavement as directed by the Engineer. All granite or brick removed shall be delivered to the designated City Yard. The cost of all labor, materials, equipment, samples and tests required and necessary to install new pavement as described herein to replace granite block, asphalt block or brick pavement over the trench width and cutbacks shall be deemed included in the prices bid for the items specified in paragraph (1)(f) above and paragraph (2)(d) above of this section. No separate or additional payment will be made for this work.

(8) If additional roadway restoration is required and ordered in writing by the Engineer outside the ordered limits of trench widths and cutbacks the cost of all labor, materials, equipment, samples and tests required and necessary to perform this additional roadway restoration work shall be deemed included in the prices bid for Item No. 4.02 CA - BINDER MIXTURE, Item No. 4.02 CB - ASPHALTIC CONCRETE MIXTURE, and Item No. 4.04 H - CONCRETE BASE FOR PAVEMENT, VARIABLE THICKNESS FOR TRENCH RESTORATION, (HIGH-EARLY STRENGTH). Included in the prices bid for these items shall be the cost for all saw cutting, excavation of pavements, tack coating, removal of pavement markings and replacement with thermoplastic reflectorized pavement markings (crosswalks and lane dividers), placement and eradication of temporary roadway markings, stripping or milling of pavement keys and adjustment of city owned castings. No separate or additional payment will be made for this work.

(9) If additional sidewalk restoration is required and ordered in writing by the Engineer outside the ordered limits of trench widths and cutbacks the cost of all labor, materials, equipment, samples and tests required and necessary to perform this additional sidewalk restoration shall be deemed included in the prices bid for Item No. 4.13 AAS - 4" CONCRETE SIDEWALK (UNPIGMENTED), and Item No. 4.13 BAS - 7" CONCRETE SIDEWALK (UNPIGMENTED). Included in the prices bid for these items shall be the cost for all saw cutting, excavation of sidewalks, 6" foundation material, etc. No separate or additional payment will be made for this work.

(11) Refer to Page VII-104:

Add the following new **DIVISION VIII**:

DIVISION VIII

DETAILED SPECIFICATION FOR RECONSTRUCTION OF COLLAPSED OR OTHERWISE DEFECTIVE STORM, SANITARY OR COMBINED VITRIFIED CLAY PIPE SEWERS

DSS-1 INTENT

It is intent of this emergency repairs contract, at all locations and areas ordered under this contract as determined by the New York City Department of Environmental Protection and as directed by the Engineer to reconstruct sections of existing collapsed or otherwise defective Storm, Sanitary or Combined Sewers in roadways, sidewalks, malls, medians, pedestrian ways, easements or other non-roadway areas including the reconnection of all existing house sewers, basin connections, and the construction of new manholes as required.

The sections of existing collapsed or otherwise defective Storm, Sanitary or Combined Sewers shall be removed and reconstructed with Extra Strength Vitrified Clay Pipe on Concrete Cradle and/or Precast Reinforced Concrete Pipe on Concrete Cradle, complete, as shown, specified or required.

The Contractor, when so ordered by the Engineer, will be required to substitute the use of Ductile Iron Pipe on Stone Bedding in lieu of Extra-Strength Vitrified Clay Pipe on Concrete Cradle for the various sized pipes indicated in the Bid Schedule. The Ductile Iron Pipe shall meet all of the requirements, standards and specifications of the Department of Environmental Protection. The payment for Ductile

Iron Pipe on Stone Bedding will be made under the applicable unit prices bid for the various sizes of Extra-Strength Vitrified Clay Pipe on Concrete Cradle. The substitution of 15-inch Extra-Strength Vitrified Clay Pipe will be made with 16-inch Ductile Iron Pipe.

At each ordered location the length of existing collapsed or otherwise defective Storm, Sanitary or Combined Pipe Sewer to be reconstructed will vary; however, the length will generally not be less than fifteen (15) feet per trench opening. The actual length at each ordered location and the area of reconstruction will be determined by the New York City Department of Environmental Protection and as directed by the Engineer. For each reconstruction less than a manhole length, the trench opening shall be at least one and one-half (1-1/2) feet longer at the ends of the reconstruction to permit proper jointing.

DSS-2 STANDARD SEWER AND WATER MAIN SPECIFICATION

Unless otherwise specified, all work and materials shall conform to the applicable sections of the Standard Sewer And Water Main Specifications of the Department of Environmental Protection (dated July 1, 2014), Sewer Design Standards of the Department of Environmental Protection (dated September 2007) Revised January 2009, Water Main Standard Drawings of the Department of Environmental Protection (latest revisions), and the Standard Highway Specifications (Volumes I and II) of the Department of Transportation (dated November 1, 2010) of The City of New York.

DSS-3 DEFINITIONS

This contract will be managed by the New York City Department of Environmental Protection's (DEP) Bureau of Water and Sewer Operations. "Engineer" means the Director of DEP's Bureau of Water and Sewer Operations, or a designated representative to act as such in relation to this contract; "Commissioner" means the Commissioner of DEP, or a designated representative to act as such in relation to this contract; "DDC Quality Assurance and Construction Safety Bureau (QACS)," or the "Director of QACS," means the Director of DEP's Bureaus of Water and Sewer Operations, who shall oversee the performance of all testing and approvals that are otherwise specified to be performed by QACS.

DSS-4 ISSUANCE OF WORK ORDERS

(A) General: The Contractor shall, for the duration of this contract, provide services as directed by the Engineer for the reconstruction of existing sewers or portions thereof, in accordance with the terms and conditions set forth herein. The services to be provided by the Contractor shall include both Initial Services and Reconstruction Services, as described below.

(B) Transmission of Notices and Work Orders:

- (1) The Engineer shall advise the Contractor of the need for services hereunder through Notices, as set forth in **Paragraph (C)** below, and Work Orders, as set forth in **Paragraph (D)** below. The Engineer shall send Notices and Work Orders to the Contractor by e-mail, fax, or by telephone promptly confirmed by e-mail and/or fax.
- (2) The Contractor shall, for the duration of this contract, provide and maintain at its place of business a dedicated telephone line, a dedicated e-mail address and a dedicated fax line for the receipt of Notices and Work Orders hereunder. The e-mail and fax machine shall be in operation twenty-four (24) hours per day, seven (7) days per week, for the duration of this contract. The Contractor shall not be entitled to any compensation for the provision of such equipment. All expenses for the required telephone, e-mail and fax lines shall be deemed included in the Contractor's overhead.

(C) Initial Services to be Provided by Contractor:

- (1) Notice: When the need for services arises, the Engineer shall issue a Notice to the Contractor. The Notice shall specify the following: (a) the location where the Contractor must provide Initial Services, and (b) the Initial Response Time.
- (2) Initial Services: The Contractors shall complete the Initial Services set forth below within the Initial Response Time specified by the Engineer in the Notice.
 - (a) Make the area safe for residents in the area of the ordered work and for pedestrian and vehicular traffic. Such work shall include, but not be limited to, the placement of adequate lighted barricades, plates, signs, as well as any other work required by the Engineer in order to make the area safe.
 - (b) As directed by the Engineer the Contractor shall:
 - (i) Commence excavation, and/or
 - (ii) Provide and operate such pumping equipment to maintain sewage flow
- (3) Initial Response Time: Initial Response Time shall mean the period of time within which the Contractor must complete the Initial Services, set forth in **Paragraph (2)** above. The Initial Response Time shall be specified in the Notice set forth in **Paragraph (1)** above. The Initial Response Time shall commence at the time the Notice is transmitted to the Contractor by fax or Email. The Contractor is advised that the Initial Response Time shall be determined by the Department of Environmental Protection, in its sole discretion and in accordance with the degree of emergency presented. The Contractor is advised that the Initial Response Time will range from a minimum of within six (6) hours of notification to a maximum of within twenty-four (24) hours of notification.

(D) Work Order: When the need for services arises, the Engineer shall issue a Work Order to the Contractor. The Work Order shall specify the items set forth below:

- (1) Description and Location of the Project
- (2) Length of Reconstruction Work
- (3) Reconstruction Services to be performed
- (4) Reconstruction Time - Time for commencement and completion of work

(E) Reconstruction Services: The Engineer shall specify the services necessary and required for reconstruction. The Contractor shall perform such reconstruction services within the reconstruction time, as set forth below.

(F) Reconstruction Time: The Reconstruction Time shall mean the period of time within which the Contractor must complete the required Reconstruction Services. The Reconstruction Time shall be specified in the Work Order. The Contractor is advised that the Reconstruction Time shall be determined by the Department of Environmental Protection, in its sole discretion and in accordance with the degree of emergency presented. The Contractor is advised that the Reconstruction Time will range from a minimum of twelve (12) hours to a maximum of forty-eight (48) hours.

Time is of the essence as the public health and safety are involved. Accordingly, the Contractor shall perform the work at each and every ordered location promptly and diligently, using such means and methods of construction as will assure its expeditious and satisfactory completion without delay.

(G) Personnel: The Contractor shall provide adequate personnel and equipment at each ordered location. Prior to the start of work the Engineer shall approve such personnel and equipment. The Engineer reserves the right to determine the personnel and equipment required to adequately and properly carry out the intent of this contract and to order personnel and equipment in excess of that normally required for the work to be done, off the job site. No payment will be made for

such excess personnel and equipment. The Contractor must be prepared to provide adequate personnel and equipment to perform the services specified in Paragraphs (C) and (E) above at up to six (6) concurrent reconstruction sites continuously and uninterrupted to completion.

- (H) No Right To Refuse: The Contractor shall have no right to reject or decline to perform any Work Order issued under this contract. However, if the Contractor is unable to begin the work of reconstruction for any reason, the Contractor shall so notify the Engineer by telephone as soon as possible, such notifications to be followed by an explanation in writing as to the reasons why the Contractor is unable to begin the required work.
- (I) Supplementary Work Orders: The Contractor shall perform only the work specifically ordered by the Engineer in the written Work Order. The Department of Environmental Protection reserves the right to order additional work through Supplementary Work Orders issued by the Engineer, as the work on the original Work Order progresses.

DSS-5 WORK INCLUDED

The Contractor shall at each and every ordered location, furnish all labor, equipment, materials and supervision, and shall perform all the work called for within each item ordered including any incidental work required for a complete and satisfactory job.

All labor, equipment and materials necessary for the proper execution and completion of each item of work called for are to be furnished and delivered by and at the cost and expense of the Contractor, and the work executed and completed in every detail whether specifically mentioned or not. The Contractor must be prepared to do this work without prepared plans.

At each ordered location the Contractor shall remove and clean the sewer of any debris up to and including manholes on both sides of the section of sewer being reconstructed during and after the completion of the work.

DSS-6 EXISTING CONDITIONS

The Contractor is advised that the Engineer will furnish to the Contractor, where available, plans of the existing collapsed or otherwise defective Storm, Sanitary or Combined Sewers.

The Contractor is further advised that since the reconstructed sewer is to be within the same trench where the existing collapsed or otherwise defective pipe sewer was constructed, it is assumed that the original trench was backfilled with acceptable materials and that no exceptionally large boulders, or other obstructions would hinder or delay the excavation work. If boulders, rip-rap and other large objects as herein before specified in excess of one-half (1/2) cubic yard in volume are encountered during the excavation down to the top of the existing collapsed or otherwise defective pipe sewer, payment for the removal of same will be paid for at the unit price bid for Item No. 70.51EO - EXCAVATION OF BOULDERS IN OPEN CUT. The entire boulder shall be measured where practicable. The resultant void shall be backfilled and paid for under Item No. 73.41AG - ADDITIONAL SELECT GRANULAR BACKFILL.

The average depth to be excavated to subgrade for the reconstructed sewer is eight (8) to nine (9) feet, varying from a minimum depth of four (4) feet to a maximum depth of twelve (12) feet. Deeper sewer excavations to a maximum depth of twenty (20) feet, shall be paid for under Item No. 73.31AE2 - ADDITIONAL EARTH EXCAVATION INCLUDING TEST PITS (OVER 12' TO 16' DEPTH), Item No. 73.31AE3 - ADDITIONAL EARTH EXCAVATION INCLUDING TEST PITS (OVER 16' TO 20' DEPTH), Item No. 73.31AE4 - ADDITIONAL EARTH EXCAVATION INCLUDING TEST PITS (OVER 20' TO 24' DEPTH), Item No. 73.31AE5 - ADDITIONAL EARTH EXCAVATION INCLUDING TEST PITS (OVER 24' DEPTH).

DSS-7 PAYMENT FOR WORK PERFORMED

The Contractor shall include in the unit price bid for each item of work, the cost of all labor, equipment, materials, supervision, overhead, profit, insurance, and all other services required to execute and complete each item of work.

Payment will be made at the unit price bid for the various items of work ordered in writing by the Engineer and actually performed and incorporated into the work. The Contractor is advised that the payment for each increment of length of sewer to be replaced will be made at the unit prices bid for each increment of length of sewer to be replaced according to the following schedule:

- (a) Minimum fifteen (15) linear feet. For example: item no. 1.A08, 1.A48, 1.C10, 1.F12, 1.I15, 1.L18, 1.O24, 1.R30, 1.U36, 1.X42.
- (b) Additional length beyond the minimum fifteen (15) linear feet to a maximum of one hundred (100) linear feet. Fixed unit price as listed in the contract document - bid schedule of prices. For example: item no. 1.B48, 1.D10, 1.G12, 1.J15, 1.M18, 1.P24, 1.S30, 1.V36, 1.Y42.
- (c) Additional length beyond one hundred (100) linear feet. Fixed unit price as listed in the contract document - bid schedule of prices. For example: item no. 1.C48, 1.E10, 1.H12, 1.K15, 1.N18, 1.Q24, 1.T30, 1.W36, 1.Z42.

DSS-8 PROCEDURAL ORDERS TO CONTRACTOR

The Contractor shall either give personal attention to the work or employ and retain a competent superintendent or foreman at each and every ordered location while the work is in progress. Instructions given to the superintendent or foreman shall be considered as having been given to the Contractor.

DSS-9 CITY TO NOTIFY CITY DEPARTMENT

At the time the Engineer orders the Contractor to proceed with the work, the Department of Environmental Protection shall notify and transmit a copy of the order to start work to all public and private agencies concerned. These notifications shall be in addition to the Contractors required notifications of public and private agencies as specified herein.

At the start of the work, the Contractor will be furnished with a temporary street opening permit by the Department of Environmental Protection. However, the Contractor shall obtain the prescribed permits from the Department of Transportation within forty-eight (48) hours of beginning the work.

DSS-10 MEASUREMENTS

All measurements shall be made under the supervision of the Engineer. The Contractor's representative shall notify the Engineer when measurements are to be made so the Engineer may be present at that time, the Contractor shall record all measurements and give the Engineer duplicate copies of these measurements.

DSS-11 WORK ORDERED BY THE ENGINEER AND NOT OTHERWISE COVERED IN THE DETAILED SPECIFICATION.

During the course of the work being performed at any ordered location, it may be necessary for the Engineer to order, in writing, extra work not otherwise covered in the work order and in the Detailed Specifications. Payment for extra work for which there are classified bid item(s) shall be made under the unit price bid for the respective bid item(s). Payment for extra work for which there are no specific classified bid item(s) shall be made in accordance with **Articles 25 and 26** of the Contract.

DSS-12 INSPECTION OF MATERIALS FURNISHED

In lieu of the procedure for the inspection of materials to be furnished, as called for in **DIVISION III** of the Standard Sewer And Water Main Specifications, the City will accept certificates from the Contractor's materials suppliers stating that the materials furnished and incorporated in the work at each ordered location, meets the requirement of the appropriate sections of the specifications. Such material certificates shall be provided to the Engineer by the completion date specified in the work order for each ordered location.

DSS-13 DISPOSAL OF WATER FROM TRENCHES (DEWATERING)

- (1) **DESCRIPTION** - The Contractor will be required, at all ordered locations where groundwater is present in the trench and as ordered by the Engineer, to install, maintain and operate a dewatering system to adequately lower the groundwater table to a point below the trench subgrade.
- (2) **METHODS** - Upon obtaining a work order to commence work at any location where dewatering is known to be required, or immediately upon discovery at any location that dewatering is required, the Contractor shall prepare working drawings and designs showing all facets of the proposed dewatering system including but not limited to; soil type, permeability, anticipated discharge amount, wellpoint spacing, depth of well points, size of header pipe, location of discharge point, etc. All of this information shall be submitted to the Engineer for review and approval. Wherever there is insufficient data available to provide accurate information on the soil properties required above, the Contractor shall be permitted to make assumptions and/or educated estimates provided that it is so stated in the submissions.
- (3) **CRITERIA** - The parameters or need for the installation of a dewatering system shall be determined by the Engineer. The location of the water table shall be a minimum of one (1) foot above subgrade and the maximum location shall be seventeen (17) feet above subgrade prior to the use of any wellpoints. These minimum and maximum heights of water table are based upon a trench depth not exceeding eighteen (18) feet. Lowering of the water level more than seventeen (17) feet is beyond the scope of this item. The use of sump pumps or open trench pumping shall not be considered for payment.
- (4) **PERMITS** - Whenever the Contractor is required to install a temporary dewatering system to lower the groundwater level within the Boroughs of Brooklyn or Queens it will be necessary to obtain a New York State Department of Environmental Conservation (NYSDEC) Long Island Well Permit. Since all work performed under the scope of this project is of an emergency nature the Dewatering Contractor will be required to notify NYSDEC as expeditiously as possible to inform them of the impending work. The Contractor will be required to submit all data and water quality test results to NYSDEC upon their request.
- (5) **MEASUREMENT AND PRICE TO COVER** - There shall be six (6) items under which payment will be made for dewatering. These are as follows:
 - (a) **Mobilization (Dewatering)** - The quantity of mobilization to be measured for payment shall be a lump sum measurement for each ordered location mobilization for dewatering performed, complete, as specified or required. The contract price for Item No. DSS008A - **MOBILIZATION (DEWATERING)** shall be the lump sum price bid for each ordered location mobilization when dewatering is required as specified herein, and shall cover the cost of all labor, materials, equipment, setting up of plant, samples, necessary design computations and drawings, tests and permits required and necessary to mobilize for dewatering at each ordered location, including the furnishing and installing of all other items necessary to complete this work and do all work incidental thereto; all in accordance with the specifications, and as directed by the Engineer.

- (b) Header and Discharge Pipe Installation - The quantity of header and discharge pipe to be measured for payment shall be the number of linear feet of header and discharge pipe incorporated in the work, complete, as shown, specified or required. The contract price for Item No. DSS008B - HEADER AND DISCHARGE PIPE INSTALLATION shall be the unit price bid per linear foot for header and discharge pipe installed and utilized at any ordered location and shall cover the cost of all labor, materials, equipment and tests required and necessary to install the header and discharge pipe at each ordered location, including the furnishing and installing of all other items necessary to complete this work and do all work incidental thereto; all in accordance with the specifications, and as directed by the Engineer.
- (c) Header and Discharge Pipe Rental - The quantity of header and discharge pipe rental to be measured for payment shall be the number of sections per day of header and discharge pipe incorporated into the work, complete, as shown, specified or required. A section of header and discharge pipe shall be measured as a ten (10) foot length or portion thereof. The contract price for Item No. DSS008C - HEADER AND DISCHARGE PIPE RENTAL shall be the unit price bid per section per day for header and discharge pipe installed and utilized at any ordered location and shall cover all costs required and necessary for rental of header and discharge pipe. Payment under this item will commence upon completion of installation and start of operation of the dewatering system. Payment will cease upon completion of the need for dewatering as approved or ordered by the Engineer.
- (d) Wellpoint Installation - The quantity of wellpoint installation to be measured for payment shall be the number of wellpoints incorporated into the work, complete, as shown, specified or required. The contract price for Item No. DSS008D - WELLPOINT INSTALLATION shall be the unit price bid per each for wellpoints installed and utilized at any ordered location and shall cover the cost of all labor, materials, equipment and tests required and necessary to install the wellpoints at each ordered location, including the furnishing and installing of all other items necessary to complete this work and do all work incidental thereto; all in accordance with the specifications, and as directed by the Engineer.
- (e) Wellpoint Rental - The quantity of wellpoint rental to be measured for payment shall be the number of wellpoints per day incorporated into the work, complete, as shown, specified or required. The contract price for Item No. DSS008E - WELLPOINT RENTAL shall be the unit price bid per each per day for wellpoints installed and utilized at any ordered location and shall cover all costs required and necessary for rental of wellpoints. Payment under this item will commence upon completion of installation and start of operation of the dewatering system. Payment will cease upon completion of the need for dewatering as approved or ordered by the Engineer.
- (f) System Operation - The quantity of system operation to be measured for payment shall be the number of hours of system operation required, during normal working hours and/or as approved or ordered by the Engineer, to operate the dewatering system, complete, as specified or required. The contract price for Item No. DSS008F - SYSTEM OPERATION shall be the unit price bid per hour for system operation at any ordered location and shall cover the cost of all labor, materials, plant and equipment required and necessary to properly operate the dewatering system at each ordered location, including the furnishing and installing of all other items necessary to complete this work and do all work incidental thereto; all in accordance with the specifications, and as directed by the Engineer. Payment under this item will be made based upon the hours the system is in operation and staffed during normal working hours and/or as approved or ordered by the Engineer. No additional or separate payment will be made for any additional costs arising out of labor overtime costs (premium costs) or for any work that is performed beyond normal work hours or on weekends. The costs thereof shall be deemed included in the unit price bid per hour of System Operation.
- (6) ADDITIONAL PAYMENT - If Header or Discharge Pipe is required to be buried to provide vehicular and/or pedestrian access as determined in writing by the Engineer, additional payments

shall be made as follows; for any excavation, removal of pavements, plating or temporary pavement, backfilling and compaction required, payment shall be made under Item No. 73.31AE2 - ADDITIONAL EARTH EXCAVATION INCLUDING TEST PITS (OVER 12' TO 16' DEPTH); for any additional fill ordered in writing by the Engineer, payment shall be made under Item No. 73.41AG - ADDITIONAL SELECT GRANULAR BACKFILL; and for any permanent pavement restoration required outside the limits of the trench widths and cutbacks, payment shall be made under the appropriate pavement restoration items.

- (7) NO ADDITIONAL PAYMENT - No additional payment will be made for any costs associated with demobilization as a result of dewatering. The costs thereof shall be deemed included in the unit prices bid for all associated dewatering items.

DSS-14 TREE CONSULTANT

(1) INTENT

The Contractor shall engage the services of a professional forester or arborist as a Tree Consultant who shall, in anticipation of the potential for work in sidewalk and roadway street areas that will affect trees, prepare a preconstruction report and serve as an advisor to the Engineer and the Contractor. The Tree Consultant shall be responsible, at all ordered locations affecting trees, for checking, inspecting and directing; all construction work around existing trees; all maintenance pruning of trees; all fertilization; and all protection of trees. The Tree Consultant shall also be responsible for ensuring and enforcing compliance of all work with these specifications, and the Department of Parks and Recreation permits, requirements, specifications and standards.

(2) DESCRIPTION

The Tree Consultant shall be a professional forester or arborist approved by the Engineer, who shall, in anticipation of the potential for work in sidewalk and roadway street areas that will affect trees, prepare a preconstruction report advising the Engineer and the Contractor as to the following:

- (a) Possible means and methods (including alternate methods) of excavation, backfill and compaction at potential sidewalk and roadway street areas that will affect trees so as to ensure the least impact upon existing trees and compliance with these specifications, and the Department of Parks and Recreation permits, specifications, and standards.
- (b) Probable means and methods (including alternate methods) of maintenance pruning operations where necessary.
- (c) Assess potential damage or injury to trees and root systems that may be caused by Contractor's operation and establish construction operation procedures for preventing such damage or injury.
- (d) And any other procedures required to satisfy these specifications, and the Borough Forester's requirements.

The Tree Consultant shall be required, at all ordered locations affecting trees, to be present at all times during the Contractor's construction operation to ensure, direct and enforce compliance by the Contractor with these specifications, and all Department of Parks and Recreation permits, requirements, specifications and standards.

The Tree Consultant shall be a person independent of and not associated with those persons performing tree pruning, protection and fertilization operations under this contract.

The Tree Consultant shall, at all ordered sidewalk street locations affecting trees, personally witness all; sidewalk, driveway, curb and roadway removal; excavation, backfill and compaction work; and tree pruning, protection and fertilization. The Tree Consultant shall, at all ordered roadway street locations

affecting trees, personally witness all; excavation, backfill and compaction work; and tree pruning, protection and fertilization. The Tree Consultant shall at each ordered location affecting trees, locate and identify all trees affected and the means and methods to be utilized for their protection. The Tree Consultant shall also approve all Contractor's construction equipment and manner of work. The Tree Consultant shall also assess any damage and recommend corrective action. The Tree Consultant shall identify trees, recommend construction alternatives to save existing trees and shall do all other work required and necessary to ensure compliance with these specifications, and the Department of Parks and Recreation permits, requirements, specifications and standards.

(3) SELECTION PROCESS

Prior to the start of work the Contractor shall submit the name and qualifications of a person whom the Contractor feels would be acceptable as a Tree Consultant.

The Tree Consultant shall submit at this time a proposal describing its relevant experience and general approach towards fulfilling the requirements and objectives of this section.

(4) QUALIFICATIONS

The minimum qualifications required for consideration as the Tree Consultant shall be as follows:

- (a) Associate degree in forestry, arboriculture, horticulture, or related plant science field, and five (5) years of full-time professional experience in landscape design and the field supervision of techniques to mitigate damage to existing trees from the negative impacts of construction; or
- (b) B.S. in forestry, arboriculture, horticulture, or related plant science field, and three (3) years of full-time professional experience in landscape design and the field supervision of techniques to mitigate damage to existing trees from the negative impacts of construction; or
- (c) M.S. in forestry, arboriculture, horticulture, or related plant science field, and one (1) year of full-time professional experience in landscape design and the field supervision of techniques to mitigate damage to existing trees from the negative impacts of construction; or
- (d) Arborist certification from the New York State Arborists/International Society of Arboriculture Chapter, Inc., and three (3) years of full-time professional experience in landscape design and the field supervision of techniques to mitigate damage of existing trees from the negative impacts of construction; or
- (e) Other state arborist certification recognized by the International Society of Arboriculture or the National Arborist Association, and three (3) years of full-time professional experience in landscape design and the field supervision of techniques to mitigate damage to existing trees from the negative impacts of construction.

(5) SUBMISSION OF REPORTS

Upon approval, the Tree Consultant will be required to submit five (5) copies of the preconstruction report together with all materials and plans required. Reports shall be bound and bear the name of the contract and signature of the preparer.

(6) MEASUREMENT

The quantity to be measured for payment of Item No. DSS006A - TREE CONSULTANT shall be the time, measured in person hours, that the Tree Consultant actually performed work on this contract as specified and to the satisfaction of the Engineer.

(7) PRICE TO COVER

The contract price bid for Item No. DSS006A - TREE CONSULTANT shall be a unit price per person hour and shall cover the cost of all labor, material, plant, equipment, inspection, reports and incidentals required to complete the work, all in accordance with the plans, specifications, standard and as directed by the Engineer and Borough Forester.

DSS-15 TREES TO BE REMOVED AND REPLACED

During the work of reconstructing sewers in sidewalk or mall areas, the Contractor, when ordered in writing by the Engineer and approved by the Parks Department, shall remove trees along the line of the work. The cost of all the labor and materials required to remove trees, as directed, shall be deemed included in the unit prices bid for the respective tree removal items.

Where trees along the line of the work are removed, as directed, the Contractor shall replace such trees with new trees in accordance with the requirements of the Department of Parks and Recreation. The cost of all the labor and materials required to furnish and place new trees, as directed, together with the cutting of tree pits and all work incidental thereto, shall be deemed included in the unit price bid for Item No. 4.16 CA405 - TREES PLANTED, 3" TO 3-1/2" CALIPER, ALL TYPES, IN 4' X 5' TREE PITS.

DSS-16 ADDITIONAL SIDEWALK RESTORATION

The Contractor is notified that during the work of reconstructing sewers at any ordered location, the Engineer may order additional sidewalk reconstruction outside the ordered trench and cutback restoration limits.

The cost of all the labor and materials required to perform this ordered additional existing concrete sidewalk removal and reconstruction outside the ordered sewer and water main trench and cutback restoration limits, together with all work incidental thereto, shall be deemed included in the unit prices bid for Item No.4.13 AAS - 4" CONCRETE SIDEWALK (UNPIGMENTED), and Item No. 4.13 BAS - 7" CONCRETE SIDEWALK (UNPIGMENTED).

It shall be understood that such sidewalk reconstruction is in addition to and does not include sidewalk restoration included in the unit price bid for the reconstruction of sewers and water mains.

DSS-17 ADDITIONAL ROADWAY RESTORATION

The Contractor is notified that during the work of reconstructing sewers at any ordered location, the Engineer may order additional roadway reconstruction outside the ordered trench and cutback restoration limits.

The cost of all the labor and materials required to perform this ordered additional existing roadway removal and reconstruction outside the ordered sewer and water main trench and cutback restoration limits, together with all work incidental thereto, shall be deemed included in the unit prices bid for Item No. 4.02 CA - BINDER MIXTURE, Item No. 4.02 CB - ASPHALTIC CONCRETE MIXTURE, and Item No. 4.04 H - CONCRETE BASE FOR PAVEMENT, VARIABLE THICKNESS FOR TRENCH RESTORATION, (HIGH-EARLY STRENGTH).

It shall be understood that such roadway reconstruction is in addition to and does not include roadway restoration included in the unit price bid for the reconstruction of sewers and water mains.

DSS-18 METHOD OF PAYMENT

The following items of work herein specified are provided in order to afford the City of New York opportunity to have such work done if found necessary. It shall be understood by the Contractor that

the work as specified under any one of these items may be ordered by the City of New York and in the unit quantities found necessary by the Department of Environmental Protection. The City of New York, however, is not bound to order any of the work specified under these items. Payment will be made only for the actual number of unit quantities ordered under each item.

In the execution of any work under any of these items, the Contractor shall see that the work is progressed as quickly as possible and without delay. All labor, equipment and materials necessary for the proper execution and completion of each item of work called for are to be furnished and delivered by and at the cost and expense of the Contractor and the work executed and completed in every detail whether specifically mentioned or not.

The contract prices for Extra Strength Vitrified Pipe Sewers and/or Precast Reinforced Concrete Pipe Sewers shall be the unit price bid per linear foot for each size, kind, class and type of sewer and shall cover the cost of all labor, materials, equipment, samples and tests required and necessary to construct the extra strength vitrified pipe sewers and/or the precast reinforced concrete pipe sewers of the sizes and to the lines and grades as shown, specified, or ordered, including the earth excavation of all materials of whatever nature encountered (See **Section 40.03 - Earth Excavation** and except excavation of concrete encased sewers and other large objects as specified herein); all pumping and work required to eliminate blockages and restore and maintain sewage flow, all sheeting and bracing; pumping; fluming; bridging; decking; breaking down and filling in of abandoned sewer appurtenances; connections; concrete cradle and encasements; maintaining flow in sewers; backfilling; cleaning up; mobilization (except mobilization for dewatering purpose); temporary restoration of street surfaces; support and maintenance of existing City structures that are encountered during excavation (including curbs, stoops, fences, copings, vaults, light poles, etc.); removal of existing collapsed or otherwise defective sewers and their foundation supports of broken stone or concrete cradle; removal, reconstruction and reconnection of existing house sewer connections together with spurs and risers for existing house connections; removal, reconstruction and reconnection of existing basin connections; removing and cleaning the sewer of any debris up to and including manholes on both sides of the section of sewer being reconstructed during and after the completion of the work at any ordered location; permanent restoration of all roadway top courses and base courses within the limits of trenches and cutbacks; permanent restoration of all sidewalks within the limits of trenches and cutbacks (sidewalks shall be restored in full flag units up to a maximum overall width of ten (10) feet) together with foundation material; permanent restoration of all curbs, malls, medians, pedestrianways and other non-roadway areas within the limits of trenches and cutbacks together with foundation materials; and furnishing and installing all other items necessary to complete this work and do all work incidental thereto, all in accordance with the plans, specifications and standards and as directed by the Engineer. In addition, included in the price hereunder shall be the cost of all labor and materials necessary to construct the concrete cradle so that it shall extend under the existing sewer one and one-half (1-1/2) feet beyond the pipe joints at each end of the reconstructed sewer; and to construct at both ends where the reconstructed sewer joins the existing sewer, joints that shall be encased with a four (4) inch thick concrete encasement, twelve (12) inches long on either side of the joint.

When additional spurs are required and ordered in writing by the Engineer for future house connections, payment shall be made for these in place additional spurs under the prices bid for Item No. 52.31V06P00 - 6" E.S.V.P. SPUR FOR HOUSE CONNECTION ON E.S.V.P. SEWER, and Item No. 52.31V08P00 - 8" E.S.V.P. SPUR FOR HOUSE CONNECTION ON E.S.V.P. SEWER.

When additional risers are required and ordered in writing by the Engineer for future house connections, payment shall be made for these in place additional risers under the prices bid for Item No. 52.21V08 - 8" E.S.V.P. RISER FOR HOUSE CONNECTION, and Item No. 52.21V10 - 10" E.S.V.P. RISER FOR HOUSE CONNECTION.

When basin connections are required and ordered in writing by the Engineer to be relayed in a new location, payment shall be made for these in place basin connections under the price bid for Item No. 52.11D12 - 12" DUCTILE IRON PIPE BASIN CONNECTION or 52.11D12C - 12" DUCTILE IRON PIPE BASIN CONNECTION (CHUTE CONNECTION WORK ONLY), 52.11D12D - 12" DUCTILE IRON PIPE BASIN CONNECTION FOR MODIFICATION AND/OR REPLACEMENT OF CATCH

BASINS, 52.11V12 – 12" EXTRA STRENGTH VIRTIFIED PIPE BASIN CONNECTION, 52.11V12C – 12" EXTRA STRENGTH VIRTIFIED PIPE BASIN CONNECTION (CHUTE CONNECTION WORK ONLY), 52.11V12D – 12" EXTRA STRENGTH VIRTIFIED PIPE BASIN CONNECTION FOR MODIFICATION AND/OR REPLACEMENT OF CATCH BASIN.

Payment for in place additional steel reinforcing bars required and ordered in writing by the Engineer shall be made under the price bid for Item No. 73.51AS - ADDITIONAL STEEL REINFORCING BARS.

Payment for in place additional select granular backfill required and ordered in writing by the Engineer shall be made under the price bid for Item No. 73.41AG - ADDITIONAL SELECT GRANULAR BACKFILL.

Payment for in place additional brick masonry required and ordered in writing by the Engineer shall be made under the price bid for Item No. 73.11AB - ADDITIONAL BRICK MASONRY.

Payment for in place standard manholes required and ordered in writing by the Engineer, shall be made under the prices bid for Item No. 51.21S0A1000V - STANDARD MANHOLE TYPE A-1, Item No. 51.21S0A2000V - STANDARD MANHOLE TYPE A-2, Item No. 51.21S0B1000V - STANDARD MANHOLE TYPE B-1, Item No. 51.21S0B2000V - STANDARD MANHOLE TYPE B-2, Item No. 51.21S0C1000E – STANDARD MANHOLE TYPE C-1 ON EXISTING SEWER, Item No. 51.21S0C2000E – STANDARD MANHOLE TYPE C-2 ON EXISTING SEWER Item No. 51.31S00100E – STANDARD DROP-PIPE MANHOLE TYPE I ON EXISTING SEWER, Included in the respective prices bid shall be the cost for the removal of existing manholes.

Payment for in place standard catch basins required and ordered in writing by the Engineer shall be made under the price bid for Item No. 51.41S001 - STANDARD CATCH BASIN, TYPE 1, Included in the respective prices bid shall be the cost for the removal of existing catch basins. Payment for excavation of boulders in open cut required and ordered in writing by the Engineer shall be made under the price bid for Item No. 70.51EO - EXCAVATION OF BOULDERS IN OPEN CUT.

Payment for in place planted trees required and ordered in writing by the Engineer, shall be made under the price bid for Item No. 4.16 CA405 - TREES PLANTED, 3" TO 3-1/2" CALIPER, ALL TYPES, IN 4' X 5' TREE PITS. Included in the price bid shall be the cost for tree pits, fertilizer, stakes and wire, topsoil, etc.

Payment for additional earth excavation required and ordered in writing by the Engineer, shall be made under the prices bid for Item No. 73.31AE2 - ADDITIONAL EARTH EXCAVATION INCLUDING TEST PITS (OVER 12' TO 16' DEPTH), Item No. 73.31AE3 - ADDITIONAL EARTH EXCAVATION INCLUDING TEST PITS (OVER 16' TO 20' DEPTH), Item No. 73.31AE4 - ADDITIONAL EARTH EXCAVATION INCLUDING TEST PITS (OVER 20' TO 24' DEPTH) and Item No. 73.31AE5 - ADDITIONAL EARTH EXCAVATION INCLUDING TEST PITS (OVER 24' DEPTH) Included in the prices bid shall be the cost for additional sheeting, bracing and pumping required beyond the limits hereinbefore mentioned.

Payment for in place stone ballast required and ordered in writing by the Engineer, shall be made under the price bid for Item No. 70.71SB - STONE BALLAST. Included in the price bid shall be the cost for additional excavation for placement of stone ballast.

Payment for in place additional concrete required and ordered in writing by the Engineer, shall be made under the price bid for Item No. 73.21AC - ADDITIONAL CONCRETE.

Payment for maintenance and protection of traffic required and ordered in writing by the Engineer shall be made under the price bid for Item No. 6.70 - MAINTENANCE AND PROTECTION OF TRAFFIC. Included in this item will be payment for making the area safe for residents and for pedestrian and vehicular traffic within the initial response time.

Payment for maintenance of site required and ordered in writing by the Engineer shall be made under the price bid for Item No. 7.13 A - MAINTENANCE OF SITE.

Payment for in place fencing required and ordered in writing by the Engineer, shall be made under the price bid for Item No. 70.31FN - FENCING.

Payment for television inspection and digital audio-visual recording of sewers required and ordered in writing by the Engineer shall be made under the price bid for Item No. 53.11DR - TELEVISION INSPECTION AND DIGITAL AUDIO-VISUAL RECORDING OF SEWERS.

Payment for removal of trees required and ordered in writing by the Engineer, shall be made under the prices bid for Item No. 4.16 AA - TREES REMOVED (4" TO UNDER 12" CALIPER), Item No. 4.16 AB - TREES REMOVED (12" TO UNDER 18" CALIPER), Item No. 4.16 AC - TREES REMOVED (18" TO UNDER 24" CALIPER), and Item No. 4.16 AD - TREES REMOVED (24" CALIPER AND OVER).

Payment for maintenance tree pruning required and ordered in writing by the Engineer, shall be made under the prices bid for Item No. 4.18 A - MAINTENANCE TREE PRUNING (UNDER 12" CALIPER), Item No. 4.18 B - MAINTENANCE TREE PRUNING (12" TO UNDER 18" CALIPER), Item No. 4.18 C - MAINTENANCE TREE PRUNING (18" TO UNDER 24" CALIPER), and Item No. 4.18 D - MAINTENANCE TREE PRUNING (24" CALIPER AND OVER).

Payment for 8-inch, 12-inch and 20-inch water main offsets and replacements required and ordered in writing by the Engineer due to water mains crossing sewer trenches and water mains interfering with sewer trenches shall be made under the prices bid for the various water main items provided in the contract for water main work actually performed.

Payment for photographs required and ordered in writing by the Engineer, shall be made under the price bid for Item No. 6.43 D - DIGITAL PHOTOGRAPHS.

DSS-19 GUARANTEED MINIMUM

In the event the Contractor is not issued any Work Orders hereunder, the City agrees to pay, and the Contractor agrees to accept, a minimum fee of two thousand dollars (\$2,000.00). The Contractor further agrees that under such circumstances, the Contractor has no action for damages or for loss of profits against the City.

D. REVISIONS TO THE SPECIFICATIONS FOR TRUNK MAIN WORK

- 1) **Refer to Part 1 – Furnishing And Delivering Steel Pipes And Appurtenances 30 Inches In Diameter And Larger, Section 11. Fabrication:, Page 4;**
Add the following to **Section 11:**

All steel water mains shall be spiral welded pipes, and all steel water main fittings shall be fabricated from qualified spiral welded pipe. Can type pipe is not acceptable except for fabrication of tees and reducers.

- 2) **Refer to Part 1 – Furnishing And Delivering Steel Pipes And Appurtenances 30 Inches In Diameter And Larger, Section 13. Special Fittings:, Page 5;**
Add the following to **Section 13:**

The steel reducer shall have a length of seven (7) feet for every twelve (12) inches reduction in diameter.

(NO TEXT ON THIS PAGE)

EP7 (2.0) - PAGES

GAS COST SHARING (EP-7) STANDARD SPECIFICATIONS

WHEN AND WHERE CONTRACTS

NOTICE

THE PAGES CONTAINED IN THIS SECTION REPRESENT THE GAS COST SHARING WORK THAT SHALL APPLY TO AND BECOME A PART OF THE CONTRACT.

(NO TEXT ON THIS PAGE)

TABLE OF CONTENT**I- NOTICE TO ALL BIDDERS; GAS COST SHARING WORK****II - GENERAL PROVISIONS; GAS COST SHARING WORK**

1. General
2. Gas Interferences And Accommodations
 - 2a. Water Main Accommodations
 - 2b. Sewer Accommodations
3. Quantity Overruns, EP-7 Funded Bid Items
4. Changes And Extra Work
5. Excavation
6. Backfilling And Street Restoration
7. Non-Responsive Bids
8. Minimum Clearances
9. Work By Facility Operator
10. Materials Furnished By Facility Operator
11. Liability And Insurance
12. Width And Depth Of Excavation
13. Depth And Crossing Angles Of Gas Facilities
14. Maintenance Of Traffic For Gas Work
15. Relocated Gas And Temporary Systems Installation
16. Role Of Company Inspector
17. Coordination With Gas Company

III - TECHNICAL SECTION

- SECTION 6.01 - Trench Crossings; Support And Protection Of Gas Facilities And Services.
- SECTION 6.02 - Extra Excavation For The Installation Of Catch Basin Sewer Drain Pipes With Gas Interferences.
- SECTION 6.02.1 - Extra Excavation For The Installation Of Catch Basin Sewer Drain Pipes With Upstream Inverts Greater Than Six (6) Feet.
- SECTION 6.03 - Removal Of Abandoned Gas Facilities. All Sizes.
- SECTION 6.03.1 - Removal Of Abandoned Gas Facilities With Possible Coal Tar Wrap. All Sizes. (For National Grid Work Only)
- SECTION 6.03.1a - Removal Of Abandoned Gas Facilities With Possible Coal Tar Wrap. All Sizes. (For Con Edison Work Only)
- SECTION 6.04 - Adjust Hardware To Grade Using Spacer Rings/Adaptors. (Street Repaving.)
- SECTION 6.05 - Adjust Hardware To Grade By Resetting. (Road Reconstruction.)
- SECTION 6.06 - Special Care Excavation And Backfilling.
- SECTION 6.07 - Test Pits For Gas Facilities.
- SECTION 6.08 - "NO TEXT"**
- SECTION 6.09 - Trench Excavation and Backfill for New Gas Mains and Services
(For National Grid Work Only)
- SECTION 6.09a - Trench Excavation and Backfill for New Gas Mains and Services
(For Con Edison Work Only)

IV - STANDARD SKETCHES; GAS COST SHARING WORK

- NO. 1 - Support Requirements For Gas Mains And Services Crossing Excavation Greater Than 4'-0" Wide At Any Angle
- NO. 1A - Support Requirements For Gas Mains Over 16" Diameter Up To And Including 48" Diameter Crossing Excavation At Any Angle
- NO. 2 - Typical Methods Of Measurement For Gas Crossings
- NO. 3 - Utility Crossings During Catch Basin Chute Connection Pipe Installation
- NO. 4 - Utility Crossings During Catch Basin Chute Connection Pipe Installation (Extra Depth)
- NO. 5 - Gas Main Encroachment On And/Or Parallel To Excavation Of Unsheeted Trench

V - PRELIMINARY GAS WORK TO BE PERFORMED BY FACILITY OPERATOR

VI - LISTING OF APPROXIMATE LOCATIONS OF EP-7 BID ITEMS QUANTITIES

I - NOTICE TO ALL BIDDERS; GAS COST SHARING WORK

All prospective bidders are hereby advised that, pursuant to the "Gas Facility Cost Allocation Act", ("the Act"), the City of New York has entered into an agreement ("the Agreement") with the gas companies (Con Edison or National Grid (formerly KeySpan Energy Delivery)) operating in their respective areas of the City to "share" the cost of facility relocation and/or support and protection of facilities disturbed by proposed water and/or sewer and related City work specified in this contract. Therefore, bid items, specifications and estimated quantities for the incremental costs of support and protection of certain gas facilities have been included in this contract. The low bid for this contract shall be determined by examining each bid for all work to be performed under this contract including any work of support and protection of gas facilities to be performed. The Contractor shall not seek additional compensation from gas companies except as specifically set forth in its contract.

II - GENERAL PROVISIONS; GAS COST SHARING WORK

1. General:

The Contractor shall perform City work with interferences from existing live and abandoned gas facilities. This shall be defined as utility work. Therefore, this contract includes bid items, specifications and estimated quantities designed to fully compensate him/her for the incremental costs of supporting, protecting, providing accommodations and, avoiding disturbing gas facilities located in the streets shown on the contract drawings. In the event that any other provisions of this contract related to gas facilities (or private utilities) conflict with these provisions, these provisions shall supersede and govern all work related to gas facilities owned by the companies operating in the project area. All utility work, as defined in these specifications, including changes and additions thereto shall be paid solely by the City except when specified otherwise in this contract. Contractor hereby agrees that the facility operator shall not be liable to pay him/her for any work performed including extra utility work. Contractor agrees that its bid prices include all compensation for loss of productivity and efficiency, idle time, delays (including any delays occasioned by negotiation of a contract change), change in operations, mobilization, demobilization, remobilization, added cost or expense, lost of profit, other damages or impact costs that may be suffered by or because of utility work, or the presence of gas facilities in the proximity of City work and that it will not seek additional compensation for these items. All disputes shall be resolved as specified in the contract.

Pursuant to the Act, Agreement, and the New York City Administrative Code, the gas company(ies) has been directed by the Commissioner and is required to perform all maintenance, repairs, replacement, shifting, alteration, relocation, and/or removal work that are not part of this contract. By having bid on this contract, the Contractor understands and agrees that the Commissioner has preasserted any right the City has to require, including the issuance of any directives or so called "order outs" under the New York City Administrative Code, any or all gas companies to maintain, repair, replace, protect, support, shift, alter, relocate, and/or remove all gas facilities that are about to be disturbed by the City contract work. The issuance of additional such directives during the performance of the contract work, where necessary in the sole judgment of the Commissioner, shall be initiated by such Commissioner as set forth in the relevant sections of the Act and Agreement. Contractor further agrees to insert such requirements as set forth herein above into any contracts with its approved subcontractors so that its subcontractors also understand and agree to such contract requirements.

2. Gas Interferences And Accommodations:

During the performance of sewer and water main work funded by the New York City Department of Environmental Protection (NYCDEP), as instructed by the Engineer, the use of any applicable contract bid item is allowed in order to resolve and accommodate all gas facilities interferences with such City work, including the removal of contaminated soil in associated trench excavation. This is in addition to the specified EP-7 bid items in the contract. Payment for such accommodation shall be funded by EP-7 bid item "UTL-GCS-2WS - GAS INTERFERENCES AND ACCOMMODATIONS" (F.S. Fixed Sum). The value of such accommodation shall be computed by multiplying the appropriate unit prices bid to the quantity of work performed, as determined by the Engineer, and applying the total amount thus to be paid

to EP-7 bid item "UTL-GCS-2WS - GAS INTERFERENCES AND ACCOMMODATIONS". When EP-7 bid item "UTL-GCS-2WS - GAS INTERFERENCES AND ACCOMMODATIONS" does not exist, such additional accommodation work shall be at no cost to the City but shall be a matter of adjustment between gas facility operator and Contractor. Private facilities, other than gas, that become in interference due to gas interferences accommodations shall also be accommodated, if so directed by the Resident Engineer, at no additional cost to the City and, provided that its owner agrees to be responsible for all additional costs to Contractor, otherwise, such facility shall be ordered by the City to be maintained, shifted, relocated or replaced by its owner at his/her expenses.

2a. Water Main Accommodations:

When water main construction is to be performed in this contract, Contractor shall be required, if warranted by field conditions, and at locations designated by the Resident or Borough Engineer, to change the vertical or horizontal alignment of water mains including but not limited to all additional labor, material, work method accommodations, furnishing, delivering and laying offset fittings and pipes, etc., necessary in order to complete water main installation and, avoid gas interferences in the project area, including street intersections. Typical work method accommodations shall include, but not be limited to, pier and plate, installation of filter fabric and select fill, etc. Such work shall be performed as directed by the Engineer and in accordance with contract specifications and latest edition of water mains standards and specifications.

2b. Sewer Accommodations:

When sewer construction is to be performed in this contract, Contractor shall be required, if warranted by field conditions, and at locations designated by the Resident or Borough Engineer, to change the horizontal alignment of sewer facilities (if possible) including but not limited to all additional labor, material, work method accommodations, furnishing, delivering and construction of additional manholes or modification of manholes/catch basins, extending chute connections, house connections, using alternate materials and methods, poured-in-place structures, etc., necessary in order to complete sewer installation and, avoid gas interferences in the project area, including street intersections. The term sewer facility shall include, but not be limited to, all sewer pipe and appurtenances, manholes, catch basins, catch basin chutes, etc. Such work shall be performed as directed by the Engineer and in accordance with contract specifications and latest edition of sewer standards and specifications.

3. Quantity Overruns, EP-7 Funded Bid Items:

(THIS SUBSECTION IS NOT APPLICABLE FOR THIS CONTRACT)

~~No quantity overrun, in excess of one hundred twenty five (125) percent, shall be permitted for EP-7 funded bid items (gas) included in this contract, except when Resident Engineer determines that such overruns are caused by field modifications to planned City work, or approved construction methods, or contract scope changes. Overruns not paid by City shall be negotiated and paid to Contractor by gas facility operator who then shall be entitled to reimbursement by NYCDEP under established cost sharing procedures.~~

4. Changes And Extra Work:

This section is not applicable to work defined under "Emergency Reconstruction Contracts" or so-called "Where and When Contracts" since these projects, by definition, inherently encounter unanticipated gas facilities and cannot be pre-engineered. In all other cases, any contract changes proposed for City work shall also cover and include all associated changes to support and protection of gas facilities affected by such changes to City work. In all other cases where the Contractor finds that City work cannot be performed as planned and specified and/or, as approved because of a need to support, protect and/or alleviate interferences from gas facilities that were not listed and/or shown, or incorrectly shown in contract plans and specifications, he shall immediately notify the Resident Engineer and the facility operators' representative of his findings. Resident Engineer shall promptly examine such claims and determine

whether or not such work is covered by contract bid items and /or specifications (contract bid items and specifications shall include city contract items as well as EP-7 items). The Resident Engineer shall also examine the claim to determine if the application of EP-7 bid item "UTL-GCS-2WS - GAS INTERFERENCES AND ACCOMMODATIONS" is appropriate to resolve the claim. If upon examination, the Engineer determines that such field conditions were unanticipated (not shown and/or listed, or incorrectly shown in contract documents) and are not covered by bid items and contract specifications, he shall then direct the Contractor and the affected facility operator to negotiate the cost of supporting and protecting, and/or alleviating the impact on City work caused by such unanticipated gas facilities with each other with the understanding that the performance of City work shall continue during negotiations. If a cost agreement is reached, the Contractor and facility operator shall adjust such costs between themselves at no additional costs to the City contract. If the Contractor and affected facility operator do not reach an agreement concerning the price to be paid for the extra work within five (5) business days of the Engineer's directive to engage into such negotiations and, after considering: public safety and inconvenience, requirements of laws and regulations applicable to private utilities, integrity of all utility systems, including but not limited to sewer and water, gas, electric, telephone and, cable TV facilities, sound engineering practices, cost (long and short term) to all affected parties, and potential City work delays, then the Resident Engineer, depending on nature and severity of interferences with City work, shall either, direct the facility operator to relocate or replace its facilities at its own discretion and cost, reimbursable by NYCDEP under established gas cost sharing procedures or, direct the Contractor to perform the utility work on actual time, material and equipment costs basis pursuant to relevant contract requirements and amendments. Contract bid prices for any applicable items of work involved shall be applied, or converted to an allowance for time and material charges. Changes shall be for affected portions of utility work and, shall be processed with EP-7 funds.

5. Excavation:

All excavators shall notify the NYC/LI One Call Center at 1-800-272-4480 at least two (2) working days, not including the day of the call, but not more than ten (10) working days in advance of the start of any excavation work. The gas company(ies) will mark out its facilities within the project limits and provide Construction Inspector(s) during all excavation work in close proximity (within twelve (12) inches) to gas facilities. The Contractor shall exercise extreme caution when excavating in the vicinity of any gas facilities. Hand excavation shall be performed within twelve (12) inches of gas facilities. The Contractor prior to excavating underneath these facilities shall adequately support all gas facilities. Standard support details for gas facilities have been included in the specifications. Any damage to gas facilities shall be reported immediately to the gas company(ies). The Contractor shall be responsible for all cost associated with repairs made necessary by damages caused by his operations.

6. Backfilling And Street Restoration:

Backfilling operations and street restorations shall be in accordance with contract requirements.

7. Non-Responsive Bids:

Every gas (EP-7) bid item has a suggested "Not less than" value per unit indicated on contract bid sheet. Bids resulting in cost of less than suggested for EP-7 items are hereby prohibited and if submitted shall be considered NON-RESPONSIVE.

8. Minimum Clearances:

Clearance requirements for City work shall govern and supersede any clearance requirement of gas facility operator. Therefore, a minimum of twelve (12) inches clearance between private utilities and City water mains, sewers or related structures to be installed in this contract shall be maintained. When this clearance is not attainable, the Resident Engineer may allow a minimum of four (4) inches clearance. With less than twelve (12) inches clearance a neoprene/polyethylene shield (to be provided by facility operator) shall be installed as part of all work item specifications. However, if Resident Engineer determines that City work cannot be performed within allowable clearance and no reasonable City accommodation (no-cost change to City work) is possible, the City shall direct the facility operator to remove, relocate, shift,

or alter their facility(ies) pursuant to the New York City Administrative Code.

9. Work By Facility Operator:

The facility operator may find it necessary to perform the following types of work during performance of City work: accommodating a contractor's request for gas facilities modifications (in order to facilitate City contractor's proposed construction method) or, remedial and emergency work on gas facilities proper with their own resources and materials if an approved method of construction for City work causes unanticipated disturbances to gas facilities or, replacing defective gas facilities when they are exposed by the Contractor and their actual conditions are observable by the facility operator. Also included in the above category of defective gas facilities are: the presence of environmental contaminants attributable to the gas facility in or around gas facilities. If such work is deemed required by the facility operator or if facility operator is directed by the City to address such deficiencies at any time during the course of construction, the Contractor shall modify the construction schedule at no cost to the City and allow the facility operator five (5) business days to perform such work without interferences. Additional costs to the facility operator (in cases of accommodations) or, Contractor (in cases of defective gas facilities) due to such gas work, if any, shall be the responsibility of the parties involved and not of the City. Such costs shall be a matter of adjustment between the Contractor and the facility operator.

10. Materials Furnished By Facility Operator:

It shall be the Contractor's responsibility to inspect material to be installed by him immediately upon delivery and advise the facility operator through its authorized representative, of all damaged materials. The Contractor at no additional costs to the City or the facility operator shall replace any material that is damaged or lost after the Contractor's inspection.

11. Liability And Insurance:

Notwithstanding the provisions of this contract, the existing division of liabilities to third parties shall remain the same as between the City and the company. Therefore, it is specifically agreed by the City, company and Contractor (by bidding on this contract) that for the purpose of any liabilities to third parties, that the City contractor performing work directly and physically relating to gas company facilities in this project, shall be deemed an agent of the company and not an agent of the City, the New York City Municipal Water Finance Authority, or the New York City Water Board. Contractor shall include the company as an additional insured on all insurance policies maintained to comply with the City's insurance requirements.

12. Width And Depth Of Excavation:

Contractor shall not be authorized to deliberately change trench or excavation widths and/or depth specified without Engineer's approval. Enlargement of any side of excavation up to eighteen (18) inches beyond pay limits (or inside face of sheeting) requested by the Contractor for the installation of certain types of sheeting may be granted. However, such enlargements or those greater than allowable shall not be approved when, in the sole judgment of the City, field conditions allow the water mains and sewer work to be performed within the limits specified and, the sole purpose of such enlargement request is to impact adjacent utilities (public or private) whose support and protection are part of this contract. Any approval shall be given at no additional cost to the City contract, including EP-7 funding, and all costs associated with unauthorized enlargements shall be the sole responsibility of the Contractor.

13. Depth And Crossing Angles Of Gas Facilities:

Where gas facilities are shown (or specified as) crossing proposed alignment of sewers, water mains, catch basins and chute connections or any other proposed excavations at specific angles (as measured off plans or sketches or specified in contract), it shall be understood that actual field measurements may deviate (plus or minus) forty-five (45) degrees from those shown or specified. The cover, or depth from street surface to top of facilities, shall be as shown or specified in contract documents, no deviation is to be assumed. Where gas facilities are not shown on contract documents, but their support and protection are otherwise included in this contract then, all references to facilities crossing at "various angles and

depth" in the gas sections shall mean that such facilities are crossing sewer, water, catch basin and, catch basin chute, and other excavations at a ninety (90) degree angle to the proposed sheeting line or side of excavation (for unsheeted trenches) with an allowable deviation of forty-five (45) degrees in any direction, except for catch basin chute excavation where the allowable deviation shall be sixty (60) degrees. Where the cover is not noted or specified, the bottom face of such facilities shall be assumed to be crossing catch basin chutes at a depth of three (3) foot eight (8) inches or less from the street surface. Paragraph No. 2 above shall apply in cases of distribution water main construction. Appropriate bid items and specifications are provided for cases where angle and depth are greater than stated above. This section also applies to work defined in "Emergency Reconstruction Contracts" or so-called "Where and When Contracts". These contracts are not pre-engineered and consequently have no drawings, sketches or determined locations and so, gas facilities encountered will be crossing existing and proposed sewer, water, catch basin/catch basin chutes and all appurtenances at various angles and depths.

14. Maintenance Of Traffic For Gas Work:

All work pertaining to gas bid items and specifications shall be performed within the contract maintenance of traffic plan as specified in the contract document. The bid price for the Maintenance and Protection of Traffic shall cover all work pertaining to gas items. The City shall make compensation for additional maintenance and protection of traffic items in connection with gas item of work only when such additional work is deemed reasonable and necessary by the Resident Engineer and is approved by him prior to its performance.

15. Relocated Gas And Temporary Systems Installation:

In cases where the Contractor is allowed to select the location for temporary construction such as, installation of dewatering headers, wells, well points, etc., he shall not disturb any gas facilities shown on sketches provided in this section. The only exception shall be, if the affected gas company agrees to such relocation and provided that the cost of such relocation is a matter of adjustment between the company and Contractor, and at no cost to the City.

16. Role Of Company Inspector:

In any case in which the City elects to perform some or all support and protection work with its own employees, personnel or contractors, the facility operator shall provide onsite inspectors to approve and certify such support and protection work (exclusive of City accommodations) performed by the City's own employees, personnel, and contractors. Facility operator's inspectors are not authorized to direct City contractor during the performance of contract work. They shall act through the City Resident Engineer and provide him/her required approvals and certifications, prior to preparing partial payments of EP-7 items, in a format and frequency to be prescribed by the appropriate City Head of Construction.

17. Coordination With Gas Company:

The Contractor shall be required to notify the gas company(ies), in writing, at least two (2) weeks prior to the start of final paving in order to allow companies to complete any unfinished gas work located within the area to be paved. Every effort shall be made to maintain gas service with minimum inconvenience to the public.

III - TECHNICAL SECTION

SECTION 6.01 - Trench Crossings; Support And Protection Of Gas Facilities And Services.

1. Description:

Under this section, the Contractor shall provide all labor, materials, equipment, and incidentals required to support and/or protect the integrity of gas mains, services and appurtenances of any sizes, configurations, and operating pressures crossing trench excavations above subgrade for planned construction of sewers and water mains facilities. A gas service shall be defined as a gas pipe of three (3) inches in diameter or less branching from the main to a customer pick up point or property valve box. A gas main may be any size pipe that is part of a distribution or transmission network other than services described above. Crossings shall be defined as gas facilities spanning the width of excavation (one side to the other side). These crossings may be at various angles and depth as shown on "Gas Cost Sharing Work Standard Sketches Nos. 1 and 1A", and as specified in "General Provisions; Gas Cost Sharing Work Paragraph No. 13" and, at the locations shown or listed in contract documents. The gas company operating in the area, (facility operator), owns these facilities. The work shall be performed in accordance with contract specifications, plans, and at the directions of the Resident Engineer in consultation with the authorized representatives of the facility operator.

2. Method Of Construction:

- A. Protection: In general, the gas facilities shall be protected as required by New York State Industrial Code 753. In particular, the Contractor shall use hand excavation methods (pick and shovel or hand held power tools) directly below the pavement base to expose the gas facilities (marked out by facility operators) and to ascertain the clearances and cover of the facilities with respect to the proposed excavation. Upon exposing the affected facilities sufficiently, at the discretion of the Resident Engineer, to ascertain the foregoing, Contractor shall be permitted to proceed with a combination of hand and machine excavation, as appropriate, outside a zone of protection whose limit shall be defined as a perimeter located twelve (12) inches from the outside face of each gas facility crossings (See "Gas Cost Sharing Work Standard Sketch No. 2"). If the facilities are in direct interference with City work, meaning that "Minimum Clearances" described in "General Provisions; Gas Cost Sharing Work Paragraph No. 8" cannot be maintained, and excavation has to be temporarily or permanently abandoned then this particular location shall become a test pit and dealt with as specified in Section 6.07, and "General Provisions; Gas Cost Sharing Work Paragraphs Nos. 2 and 8".
- B. Support: Gas mains or services crossing excavations equal or less than four (4) feet wide are generally self supporting, unless field conditions as determined by the Resident Engineer require otherwise. The support requirements for gas mains and services crossing excavations greater than four (4) feet wide shall be as shown on the attached "Gas Cost Sharing Work Standard Sketch No. 1" and Contractor shall use sheeting methods that permit the maintenance of gas facilities in their existing locations and configurations. Alternate methods equivalent to those shown on the sketch or accommodations by the facility operator proposed by the Contractor in order to facilitate the execution of the specified work shall be allowable, provided that prior approval is obtained by the Contractor from the Engineer and the facility operator. The support and protection of gas facilities crossings shown on plans, drawings, listings or otherwise identified in this contract shall not be circumvented with the issuance of so called "order outs".

3. Method Of Measurement:

The Contractor shall be paid for supporting and/or protecting gas facilities crossing trench excavations under the appropriate bid items covered by this section. The Contractor shall be directly responsible to the facility operator for the total cost of using any alternate method requiring the use of resources owned by the facility operator. Regardless of the method used, the City shall pay the bid price for the appropriate support and/or protect item of work. The average rate charged by the facility operator for alternate support and protection work such as, disconnecting and reconnecting gas services is listed in attached "Schedule GCS-A".

4. Payment Restrictions:

These items shall not be paid for: gas services crossing unsheeted water main trench excavation; abandoned gas main/services identified by facility operator; gas mains/services crossing trench

excavations for fire hydrant branch connections pipes, catch basins and/or chutes (sewer drain pipe), house sewer and/or water services; gas facilities encroaching any face of excavation for sewer and/or water construction, all of which are covered under other contract sections. Also this item shall not be paid for new gas mains and services crossing water trenches when trenching for such new facilities has been performed by the Contractor in common with trench excavation for City work (overlapping trench limits). The cost of supporting and protecting such gas facilities crossings shall be deemed included in the cost of trench excavation for the new gas facilities. This payment restriction shall apply even if such common trench gas excavation is not part of the contract. The prices bid for items covered by this section represent full compensation to Contractor to completely perform the work described. No other bid items shall be combined with these items in order to pay for gas main and/or services crossing excavations specified herein.

5. Method Of Payment:

Each (Ea.) gas facility crossing trench excavation as described in these specifications shall be counted for payment.

6. Price To Cover:

The cost of timber/steel supports installed for gas facilities shall be included in the bid price. The bid price for each crossing shall also cover all additional supervision, labor, material (except those provided by the facility operator), equipment and insurance necessary to completely maintain the gas facilities without disruption of service to the customers and in accordance with contract plans, specifications and facility operator standards. The price shall also include: changes of method of operations; sheeting modifications where necessary to accommodate the gas facilities crossings; installation and removal of water pipe under gas facilities (so called "snaking"); extra care during excavation (including hand excavation under existing single and multiple gas facilities); extra backfilling and compaction around, over and under gas facilities; installation and removal of sheeting around gas facilities; associated maintenance and protection of traffic; barricades; and traffic plates that may be required to temporarily close and/or complete the work.

SECTION 6.02 - Extra Excavation For The Installation Of Catch Basin Sewer Drain Pipes With Gas Interferences.

1. Description:

Under this item, the Contractor shall provide all labor, materials, equipment, insurance, and incidentals for the extra excavation associated with the installation of catch basin sewer drain pipes (chute) under gas facilities of various sizes crossing the trench excavation at various angles and depth at the locations shown in the contract documents and also, for the support and protection of these facilities during associated excavation and backfill operations. The gas company operating in the area, (facility operator), owns these facilities.

2. Method Of Measurement:

The bid price shall be per location (Each) where extra excavation is required when catch basin sewer drain pipes are installed at an upstream invert depth lower than four (4) feet (up to a maximum of six (6) feet) from the proposed pavement grade because the bottom faces of interfering gas mains and appurtenances are located at a depth greater than three (3) foot eight (8) inches from proposed pavement surface (See "Gas Cost Sharing Work Standard Sketch No. 4").

3. Method Of Construction:

Incremental cost responsibility for chute excavation is determined by the first private facility encountered starting from catch basin structure proper and that prevents the installation of the chute connection at an upstream cover less than or equal to three (3) feet or any other minimum cover required to avoid City

facilities (e.g. water, sewer, etc.) as directed by the Resident Engineer.

4. Payment Restrictions:

This item shall not apply and related bid item shall not be paid in cases where:

- A. Upstream invert chute is more than six (6) feet deep because of gas facilities.
- B. Chute cannot be installed above existing gas facilities because of interferences with other private facilities that are not otherwise covered under this contract, regardless of upstream invert depth.

The above cases shall be at no cost to the City, but shall be a matter of adjustment between the Contractor and the facility operator(s).

5. Price To Cover:

The bid price shall cover the additional cost of all additional supervision, labor, materials, equipment and insurance, to complete the installation of catch basins and associated sewer connections in accordance with the contract plans and specifications. The price shall include: excavation by hand around and under single and multiple gas facilities; locating, supporting and protecting gas facilities; backfilling and all other items necessary to perform all work incidental thereto including: installation and removal of drain pipe under gas facilities ("snaking"); widening of trenches to facilitate the above work; subsequent additional backfill and pavement restoration; modifying precast catch basin window to accommodate connection; changing sheeting method and configuration to accommodate gas facility crossings; maintenance and protection of traffic; barricades; and installation of traffic plates that may be required to temporarily close and/or complete the work. The price shall not include removal of ledge rock and/or excavation of boulders in open cut.

SECTION 6.02.1 - Extra Excavation For The Installation Of Catch Basin Sewer Drain Pipes With Upstream Inverts Greater Than Six (6) Feet.

1. Description:

Under this item, the Contractor shall provide all labor, materials, equipment, insurance and incidentals for the extra excavation of catch basin chutes where the upstream invert is greater than six (6) feet under gas facilities of various sizes crossing the trench excavation at various angles and depth at the locations shown in the contract documents or as determined by field conditions and also, for the support and protection of these facilities during the associated excavation, sheeting and backfilling operations.

2. Method Of Measurement:

The bid price shall be per location (Each) where extra excavation and sheeting is required when the catch basin chute installed at an upstream invert depth lower than six (6) feet from the proposed pavement grade because the bottom faces of the interfering gas mains and appurtenances are located at a greater depth than three foot eight inches from the proposed pavement surface only.

3. Method Of Construction:

Incremental cost responsibility for chute excavation is determined by the first private facility encountered during such excavation when initiated from catch basin structure and that prevents the installation of the chute at an upstream cover less than or equal to three (3) feet or any other cover required to avoid City facilities as directed by the Resident Engineer.

4. Payment Restriction:

This item shall not apply and related bid item shall not be paid in cases where:

Upstream invert chute is less than or equal to six (6) feet deep because of gas facilities. Section 6.02 shall be paid.

5. Price To Cover:

The bid price shall cover the additional cost of all supervision, labor, materials, equipment and insurance to complete the installation of catch basin and associated sewer connections in accordance with the contract plans and specifications. The price shall include: excavation by hand around and under single and multiple gas facilities; locating, supporting and protecting gas facilities incidental thereto; widening of trenches to facilitate the above work; subsequent additional backfilling and pavement restoration; modifying pre-cast basin window to accommodate connection; the installation of catch basin with deeper sumps as specified; additional sheeting and changes in sheeting method and configuration to accommodate gas facility crossings; maintenance and protection of traffic; barricades; and installation of traffic plates that may be required to temporarily close and/or complete the work.

SECTION 6.03 - Removal Of Abandoned Gas Facilities. All Sizes.

1. Description:

Under this section the Contractor shall provide all labor, materials, equipment, insurance and, incidentals required for the removal of abandoned gas mains, services, or appurtenances thereof, located within the street shown on the contract plans, owned by gas company operating in the project area (facility operator), used or to be used for or in connection with or to facilitate the conveying, transportation, distribution or furnishing of gas (natural or manufactured or mixture of both) for light, heat, or power, but does not include property used solely for or in connection with business of selling, distributing or furnishing of gas in enclosed containers. Such removal shall include only abandoned gas facilities that interfere with (i.e. cause additional work) City work.

2. Determination Of Operating Status Of Gas Facilities:

The Contractor shall notify facility operator, as required by New York State Industrial Code 753. Gas facilities shall not be removed without the approval of the facility operator whose authorized representative shall certify in writing (specific facility or area wide facilities certification) and in a timely manner acceptable to the Resident Engineer that abandoned facilities are free of combustible gas and any other environmental contaminants prior to removal. The Resident Engineer shall rely on facility operator's certification. The facility operator may request the excavation of test pits (See Section 6.07) for this determination ahead of City work and, Contractor shall provide safe access, facilitate and permit facility operator to enter test pit excavations for the purpose of testing gas facilities to be removed by the Contractor. However, facility operator may prefer to make this test during performance of City work, in order to issue the above certification. This shall be permitted provided that it is agreed that additional costs, if any resulting from this choice shall be a matter of adjustment between the Contractor and facility operator only, and at no cost to the City.

3. Restrictions:

The facility operator shall be solely responsible for its contaminated gas facilities, surrounding contaminated soil and their disposal and abatement procedures, unless contract bid items are applicable and provided for such work. In such cases, the quantity removed shall be charged to EP-7 bid item "UTL- GCS-2WS - GAS INTERFERENCES AND ACCOMMODATIONS" at the City bid prices.

4. Method Of Measurement:

Abandoned gas pipeline removal shall be measured for payment per linear foot of pipe and appurtenances removed.

5. Price To Cover:

The price shall cover all additional cost of supervision, labor, materials, equipment, and insurance necessary to complete this work in accordance with the contract plans and specifications, including excavation by hand around and under other City and facility operator owned properties and, where necessary, support and protection of such properties. The price shall also cover breaking, cutting, and/or burning of abandoned gas pipes and their disposal from the site; sealing open ends remaining in the excavation with concrete or caps (caps to be provided by the facility operator) and backfilling of the area where the pipeline has been removed with clean backfill. The price shall also include any required dump charges. This item does not include any type of extra excavation, backfilling, compaction, pavement removal and restoration associated with abandoned gas facilities removal, all of which are covered under Section 6.06.

SECTION 6.03.1 - Removal Of Abandoned Gas Facilities With Possible Coal Tar Wrap. All Sizes. (For National Grid Work Only)

1. Description:

Under this section the Contractor shall provide all labor, materials, equipment, insurance and, incidentals required for the removal of abandoned gas mains, services or appurtenances thereof, located within the street shown on the contract plans, owned by the gas company operating in the project area (facility operator), used or to be used for or in connection with or to facilitate the conveying, transportation, distribution or furnishing of gas (natural or manufactured or mixture of both) for light, heat, or power, but does not include property used solely for or in connection with business of selling, distributing or furnishing of gas in enclosed containers. Such removal shall include only abandoned gas facilities that interfere with (i.e. cause additional work) City work. These gas facilities may be coated with Coal Tar Wrap and so, may require special handling and disposal methods as specified in National Grid Standard Operating Procedure 12-2, Coal Tar Wrap Handling and 12NYCRR56.

2. Determination Of Operating Status Of Gas Facilities:

The Contractor shall notify facility operator, as required by New York State Industrial Code 753. Gas facilities shall not be removed without the approval of the facility operator whose authorized representative shall certify in writing (specific facility or area wide facilities certification) and in a timely manner acceptable to the Resident Engineer that abandoned facilities are free of combustible gas and any other environmental contaminants prior to removal. The Resident Engineer shall rely on the facility operator's certification. The facility operator may request the excavation of test pits (See Section 6.07) for this determination ahead of City work and, the Contractor shall provide safe access, facilitate and permit facility operator to enter test pit excavations for the purpose of testing gas facilities to be removed by the Contractor. However, the facility operator may prefer to make this test during performance of City work, in order to issue the above certification. This shall be permitted provided that it is agreed that additional costs, if any, resulting from this choice shall be a matter of adjustment between the Contractor and the facility operator only, and at no cost to the City contract. Should such investigation result in the determination that the abandoned gas facilities do not contain Coal Tar Wrap then the removal of said facilities shall be covered under separate item (See Section 6.03).

3. Requirements:

The City Contractor shall excavate abandoned gas facility sufficiently, either in its entirety, or at locations determined by Contractor to allow the removal of Coal Tar Wrap (if present on the abandoned gas facility) and to facilitate the safe extraction of manageable lengths of abandoned pipe without damage to adjacent facilities, utilities or City structures either parallel to or crossing above or below abandoned gas facility. The Contractor is to allow access to the designated cutting points within the Contractor's trench by authorized National Grid personnel who will remove the Coal Tar Wrap as per National Grid procedures. This work by National Grid personnel shall be performed in a timely fashion and shall not unduly impede

the Contractor's progress and/or productivity. Upon completion of the coating removal, the Contractor shall be allowed to cut, burn or grind the gas facility and remove the section of abandoned pipe. The Contractor at a site designated by the Contractor shall stockpile the removed pipe. The facility operator will be responsible to provide trucking and disposal services with its own personnel and shall remove the stockpiled pipes during off hours or during such time as agreed to by the Contractor. Since the pipe removed will remain the property of the facility operator and is to be disposed of by the facility operator, the facility operator shall be responsible for any required notifications, filings, dump charges and incidentals associated with the disposal of abandoned gas facilities found to contain Coal Tar Wrap.

4. Method Of Measurement:

Abandoned gas pipeline removal shall be measured for payment per linear foot of pipe and appurtenances removed.

5. Price To Cover:

The price shall cover all additional cost of supervision, labor, materials, equipment and insurance necessary to complete this work in accordance with the contract plans and specifications, including excavation by hand around and under other City and facility operator owned properties and, where necessary, the support and protection of such properties. The cost shall also include hand excavation in the area(s) of proposed abandoned pipe cut(s), cutting and/or burning of abandoned gas pipes and stockpile of removed sections of abandoned pipe and associated maintenance and protection of traffic, blocking and temporary fencing if required. The unit price shall also cover sealing open ends remaining in the excavation with concrete or end caps (end caps to be provided by the facility operator) and backfilling of the area where the abandoned pipeline has been removed with clean backfill material. This item does not include any type of extra excavation, backfilling, compaction, pavement removal and/or restoration (temporary and permanent) associated with abandoned pipe removal ("lost trench"), all of which are covered under separate Section 6.06. The price shall also include allowance for any loss of productivity by the Contractor due to required facility operator work to remove pipe coating and prepare pipe for cutting as well as any change in Contractor's excavation method, additional trucking and/or stockpiling costs.

SECTION 6.03.1a - Removal Of Abandoned Gas Facilities With Possible Coal Tar Wrap. All Sizes. (For Con Edison Work Only)

1. Description:

Under this section the Contractor shall provide all labor, material, equipment, insurance and, incidentals required to prepare abandoned gas mains, services and appurtenances thereof located within the street shown on contract plans, owned by the gas company operating in the project area (facility operator), for removal due to interference with proposed City work. These abandoned gas facilities were, at one time, used for or in connection with or to facilitate the conveying, transportation, distribution or furnishing of gas (natural, manufactured or a combination of both) for light, heat, or power, but does not include property used solely for or in connection with business of selling, distribution or furnishing of gas in enclosed containers. Such preparation for removal shall include only abandoned gas facilities that interfere with (i.e. cause additional work) City work. These gas facilities may be coated with Coal Tar Wrap which may contain asbestos or PCB's and so, may require special handling and disposal methods as specified in Con Edison - ASBESTOS MANAGEMENT MANUAL, CHAPTER 6 - ASBESTOS WORK PROCEDURES, SECTION 06.04 - COAL TAR WRAP REMOVAL. For under 25' (feet) in length and an approved NYC-DEP variance for over 25' (feet).

2. Determination Of Operating Status Of Gas Facilities:

The Contractor shall notify facility operator, as required by New York State Industrial Code 753. Gas Facilities shall not be removed without the approval of the facility operator whose authorized representative shall certify in writing (specific facility or area wide facilities certification) and in a timely

manner acceptable to the Resident Engineer that abandoned facilities are free of combustible gas and any other environmental contaminants prior to removal. The Resident Engineer shall rely on the facility operator's certification. The facility operator may request the excavation of test pits (See Section 6.07) for this determination ahead of City work and Contractor shall provide safe access, facilitate and permit facility operator to enter test pit excavations for the purpose of testing gas facilities. However, the facility operator may prefer to make this test during performance of City work in order to issue the above certification. This shall be permitted provided that it is agreed that additional costs, if any, resulting from this choice shall be a matter of adjustment between the Contractor and the facility operator only, and at no cost to the City contract. Should such investigation result in the determination that the abandoned gas facilities do not contain Coal Tar Wrap then the removal of said facilities shall be covered under separate item (See Section 6.03).

3. Requirements:

The Contractor shall excavate abandoned gas facility sufficiently, either in its entirety, or at locations determined by Contractor to allow the removal of Coal Tar Wrap (if present on the abandoned gas facility) and to facilitate the safe extraction of manageable lengths of abandoned pipe without damage to adjacent facilities, utilities or city structures either parallel to or crossing above or below abandoned gas facility. The Contractor is to allow access to the designated cutting points within the Contractor's trench by authorized Con Edison personnel who will remove the Coal Tar Wrap as per Con Edison and/or NYC-DEP approved procedures. This access shall conform to all applicable codes, rules & regulations. This work by Con Edison personnel shall be performed in a timely fashion and shall not unduly impede the Contractor's progress and/or productivity. Upon completion of the coating removal, the Contractor shall be allowed to cut, burn or grind the gas facility and remove the section of abandoned pipe. Contractor shall designate a specific site to stockpile those removed pipes. The facility operator will be responsible to provide trucking and disposal services with its own personnel and shall remove the stockpiled pipes during off hours or during such time as agreed to by the Contractor. Since the pipe removed will remain the property of the facility operator and is to be disposed of by the facility operator, the facility operator shall be responsible for any required notifications, filings, dump charges and incidentals associated with the disposal of abandoned gas facilities found to contain Coal Tar Wrap.

4. Method Of Measurement:

Abandoned gas facility removal shall be measured for payment per linear foot of pipe and appurtenances removed.

5. Price To Cover:

The price shall cover all additional cost of supervision, labor, materials, equipment and insurance necessary to complete this work in accordance with the plans and specifications, including, but not limited to, excavation by hand around and under other City and facility operator owned properties and, where necessary, the support and protection of such properties. The cost shall also include hand excavation in the area(s) of proposed abandoned pipe cut(s), cutting and/or burning of abandoned gas pipes and stockpile of removed sections of abandoned pipe and associated maintenance of traffic, blocking and temporary fencing if required. The unit price shall also cover sealing open ends remaining in the excavation with concrete or end caps (end caps to be supplied by facility operator) and backfilling of the area where the abandoned pipeline has been removed with clean backfill material. This item does not include any type of extra excavation, backfilling, compaction, pavement removal and/or restoration (temporary and permanent) associated with abandoned pipe removal ("lost trench"), all of which are covered under separate Section 6.06. The price shall also include allowance for any loss of productivity by the Contractor due to required facility operator work to remove pipe coating and prepare pipe for cutting as well as any change in Contractor excavation method, additional trucking and/or stockpiling costs.

SECTION 6.04 - Adjust Hardware To Grade Using Spacer Rings/Adaptors. (Street Repaving.)

1. Description:

Under this section, the Contractor shall provide all labor, supervision, materials, equipment, insurance and incidentals required to adjust to final grade gas street surface hardware located within the contract area boundaries shown on the plans. The gas company operating in the area, (facility operator), owns these facilities. The work shall be performed in accordance with the contract plans, specifications and at the directions of the Resident Engineer in concurrence with authorized representative of the facility operator.

2. Materials:

The facility operator shall furnish and deliver all prefabricated hardware parts required. These include adaptors for the grade adjustment proper and new street hardware if existing ones are found to be defective, all in accordance with the facility operator standards and City rules and regulations. The Contractor shall notify the facility operator of the installation schedule at least three (3) business days before materials are required on the site. Should the facility operator fail to deliver the necessary material according to any schedule mutually agreed upon by the Contractor and facility operator, the City shall not be responsible for any delays attributable thereto, nor for the failure of delivery of such materials. On project where material storage is not permitted on site, the facility operator shall deliver the required material to the Contractor's yard and it shall be the Contractor's responsibility to transport the material to the work site when needed for installation. It shall also be the Contractor's responsibility to inspect the materials to be installed by him immediately upon delivery and advise the facility operator through its authorized representative, of all damaged materials. The Contractor at no additional expense to the City or the facility operator shall replace any material that is damaged or lost after the Contractor's inspection.

3. Method Of Measurement:

The Contractor shall be paid for each six (6) inch round box and/or nine (9) inch square box adjusted to grade regardless of adjustment height requirements.

4. Price To Cover:

The unit price bid for this item shall include all additional labor, supervision, insurance, equipment and material (except those to be provided by the facility operator), required to adjust each box to grade as required in the contract plans and specifications. The bid price shall also include the removal of existing frames and covers from existing facilities to be salvaged and returned to the facility operator and, all material transportation from the Contractor's material storage yard to the work site. In addition the bid price shall include "chipping" around existing box using appropriate means and methods where grinding is required.

SECTION 6.05 - Adjust Hardware To Grade By Resetting. (Road Reconstruction.)**1. Description:**

Under this item, the Contractor shall provide all labor, supervision, materials, equipment, insurance and incidentals required to adjust to the proposed grade gas street surface hardware located within the contract area boundaries shown on the plans. The gas company operating in the area, (facility operator), owns these facilities. The work shall consist of either building up or lowering or resetting the casting by removing the existing frame and cover building up or decreasing the existing installation, replacing the frame and/or cover if damaged or worn out, as determined by the Resident Engineer, with a new frame and/or cover furnished by the owner, and setting the frame and cover to new elevation. The work shall be performed in accordance with the contract plans, specifications and at the directions of the Resident Engineer.

2. Materials:

The facility operator shall furnish and deliver all new hardware parts required. The Contractor shall furnish

materials such as mortar, bricks and concrete in compliance with contract requirements. At locations where high-early strength concrete is required under this contract to be placed adjacent to gas facilities, then the requirement for concrete shall be high-early strength complying with the current New York State Department of Transportation, Standard Specifications for Class F concrete. Existing castings may be replaced as required and deemed necessary by the Engineer and by City rules and regulations. The Contractor shall install the new castings of various sizes furnished by the facility operator. The Contractor shall notify the facility operator of the installation schedule at least three (3) business days before materials are required on the site and, shall provide off-loading services to the facility operator. Should the facility operator fail to deliver the necessary material according to any schedule mutually agreed upon by the Contractor and facility operator, the City shall not be responsible for any delays attributable thereto, nor for the failure of delivery of such materials. Such delays shall be a matter of adjustment between the Contractor and the facility operator. On project where material storage is not permitted on site, the facility operator shall deliver the required material to the Contractor's yard and it shall be the Contractor's responsibility to transport the material to the work site when needed for installation. It shall also be the Contractor's responsibility to inspect the materials to be installed by him, immediately upon delivery and advise the facility operator through its authorized representative, of all damaged materials. The Contractor at no additional expense to the City or the facility operator shall replace any material that is damaged or lost after the Contractor's inspection.

3. Methods Of Construction:

The Contractor shall remove and reinstall existing castings or install new castings to the proposed grade. Setting and resetting the castings shall be done with mortar and brick according to the standards of the facility operator. Work shall be performed in a workmanlike manner. Castings that are deemed unacceptable for resetting shall remain the property of the facility operator and he shall be responsible for their removal and proper disposal from site. No traffic shall be allowed on adjusted street hardware until permitted by the Engineer.

4. Method Of Measurement:

The Contractor shall be paid for each gas hardware adjusted to grade regardless of size or adjustment height requirements (up or down).

5. Price To Cover:

The unit price bid for this item shall include all additional labor, supervision, insurance, equipment and material (except those to be provided by the facility operator), required to adjust each gas hardware to grade as required in the contract plans and specifications. The bid price shall also include the removal of existing frames and covers from existing facilities; building up the existing installations with bricks and mortar, or lowering the existing installation by removing bricks and mortar; replacing damaged frames and/or covers with new frames and/or covers furnished by the facility operator; setting the frames and covers to the new elevations; protect existing installations; repair minor structural damages to existing installations prior to resetting frames; unloading of furnished castings at the Contractor's yard and transporting castings from the Contractor's yard to the job site as required; completing the work in accordance with the contract plans, specifications and, at the directions of the Engineer. In addition the bid price shall include "chipping" around existing gas facilities using appropriate means and methods where grinding is required.

SECTION 6.06 - Special Care Excavation And Backfilling.

1. Description:

Under this section, the Contractor shall provide all labor, materials, equipment, insurance and incidentals required to support and protect the integrity of live gas facilities including mains, services, related structures and appurtenances during excavations. The gas company operating in the area, (facility operator), owns these facilities. The work shall be performed in accordance with the contract plans, specifications and

at the directions of the Resident Engineer in consultation with authorized representatives of the facility operator.

2. Applicability Of Section:

This section shall apply to live gas facilities of various sizes located within two (2) feet of any face of unsheeted excavation, (unsheeted excavation refers to any excavation performed for city work and includes excavations performed that are to be subsequently sheeted using approved methods) and paralleling or, encroaching any face of excavation. Also, for crossings greater than forty-five (45) degrees and/or located at a cover depth greater than five (5) feet from existing street surface. Parallel facilities are not exposed at any time during excavation (See "Gas Cost Sharing Work Standard Sketch No. 5"). Encroaching facilities are partially exposed inside the limit of excavation (See "Gas Cost Sharing Work Standard Sketch No. 5"). This section shall also apply to gas facilities crossing catch basins excavation, and catch basins sewer connections (chutes) trench excavation only when extra depth (covered in other section), is not required for chutes installations because of such utilities interferences (See "Gas Cost Sharing Work Standard Sketch No. 3"). This section shall also apply to gas services (if shown or otherwise listed in contract documents) crossing unsheeted excavations for water mains, gas facilities crossing fire hydrant branch connections, house sewer and/or water service connections excavations. This section shall also apply for so called "loss trench", as described further, and for additional excavation (pavement and/or soil), backfilling, compaction, roadway base and pavement restoration due to abandoned gas facilities, only if removed by Contractor. If operating status of gas facilities cannot be determined prior to excavation then such facilities shall be considered live and this section shall fully apply. The excavation around fully exposed live gas facilities along and within limits of excavation (not crossings) shall be covered by this section also (not shown on "Gas Cost Sharing Work Standard Sketch No. 5"), however the support requirement, if any is required, of such facilities is beyond the scope of these specifications and therefore shall be the responsibility of facility operator to determine and prescribe, at no cost to the City contract, but shall be a matter of adjustment between the Contractor and facility operator.

3. Payment Restriction:

No special care excavation shall be paid for abandoned gas facilities paralleling and/or encroaching excavation and therefore are not in direct interference with City work. Except as allowed in this section, the bid item specified under this section shall not be used in combination with items covered under other sections for work done due to a particular gas facility. This item shall not be paid for new gas facilities when trenching for such new facilities has been performed by the Contractor of record in common with trench excavation for City Work (overlapping trench limits). The cost of excavating with care as defined in this section shall be deemed included in the cost of trench excavation for the new gas facilities. This restriction shall apply even if such gas common trench excavation is not part of the contract. If facilities are in direct interference with City work, meaning that "Minimum Clearances" described in "General Provisions; Gas Cost Sharing Work Paragraph No. 8" cannot be maintained and excavation has to be temporarily or permanently abandoned then this particular location shall become a test pit and dealt with as specified in Section 6.07 and "General Provisions; Gas Cost Sharing Work Paragraphs Nos. 2 and 8".

4. Method Of Construction:

All excavation in the vicinity of gas facilities shall be as required by NYS Industrial Code 753. Where these facilities are paralleling and located two (2) feet or less from the limits of the proposed excavation, the Contractor shall use hand excavation methods (pick and shovel or hand held power tools) to ascertain the clearances of these facilities with respect to the proposed excavation. Once the location of these facilities with respect to the proposed excavation is verified to the satisfaction of the Resident Engineer, the Contractor shall then proceed with a combination of hand and machine excavation as required preserving the integrity of the facilities. The installation of timber supports or underpinning, when soil foundation cannot fully support partially exposed pipes, may be required to prevent pipe movement as directed by the Resident Engineer.

5. Method Of Payment:

The unit price for this work item shall be based on cubic yard (CY) of average excavation with care and, is to be considered as an incremental cost for performing City work with gas facilities interferences.

6. Method Of Measurement:

- A. For Paralleling Facilities: Volume calculated as: Depth as measured from existing street surface to the bottom of unsheeted trench excavation allowable by OSHA regulations, multiplied by, the width measured as one (1) foot from the face of excavation toward the center of excavation, multiplied by the length of parallel facility, divided by twenty-seven (27) cubic feet per cubic yard (See "Gas Cost Sharing Work Standard Sketch No. 5"). The gas facility is no longer considered to be in interference once sheeting has been installed, therefore no further compensation for paralleling facilities as described above will be made.
- B. For Encroaching Facilities: Volume calculated as: Depth of trench as allowable by OSHA, maximum up to five (5) feet multiplied by, the width of partially exposed pipe plus one (1) foot, multiplied by the length of facility encroachment, divided by twenty-seven (27) cubic feet per cubic yard (See "Gas Cost Sharing Work Standard Sketch No. 5").
- C. Fully Exposed Gas Facilities: (Not shown on "Gas Cost Sharing Work Standard Sketch No. 5") along and inside trench and/or crossing trench at an angle greater than forty-five (45) degrees and/or a cover depth greater than five (5) feet from the existing street surface. The volume shall be measured as the depth of trench excavation multiplied by the distance measured along the sheeting line between two (2) points of intersections of the gas facilities and the sides of trench excavation, multiplied by the width of trench excavation.
- D. For Additional Excavation And Restoration Due To So Called "Loss Trench", When The Integrity Of Pavement And Soil Above And Around Existing Live Gas Facilities Cannot Be Maintained Due To Its Lack Of Cohesiveness: Volume shall be calculated as: Depth of unsheeted trench excavation multiplied by width measured as distance of facility from closest edge of unsheeted excavation plus, width of facility proper plus, one (1) foot or a maximum width of three (3) feet multiplied by length of facility fully exposed divided by, twenty-seven (27) cubic feet per cubic yard (not shown on "Gas Cost Sharing Work Standard Sketch No. 5").
- E. For Facilities Crossing Excavation For Catch Basins, Or Chutes Installations (When NYCDEP Funded) Or Fire Hydrant Branch Connections, Or Unsheeted Water Main Trench, Or House Sewer And/Or Water Services: Volume calculated as: Depth as measured from existing street surface to the bottom of the trench excavation multiplied by, the width taken as the outside diameter of pipe or the width of structure plus one (1) foot on either side (two (2) feet), multiplied by, the length of exposed facility crossing the trench, divided by twenty-seven (27) cubic feet per cubic yard (not shown on "Gas Cost Sharing Work Standard Sketch No. 5").

Overlapping volume dimensions measured as described above may occur when multiple facilities are paralleling excavations, encroaching excavations or crossing catch basins and catch basin chute installations. In such cases, all such facilities shall be counted as one limited by the extreme pipes, faces (See "Gas Cost Sharing Work Standard Sketch No. 2"). The volume shall then be calculated as described above.

7. Price To Cover:

The bid price shall also cover all additional supervision, labor, material, equipment and insurance necessary to excavate while protecting and maintaining (excluding supports for fully exposed live gas) gas facilities without disruption of service to the public and in accordance with contract specifications. The price shall also include, changes of sheeting method and excavation width configuration where necessary to accommodate gas facilities in their existing locations; difficulties during the installation of catch basins, chute connections, hydrant branch, and house sewer and water connections under or over gas facilities; loss of productivity due to slower rate of excavation (special care) during excavation, including the use of such methods as: hand excavation around existing single and multiple facilities, extra excavation and

backfilling due to lost trench because of existing and adjacent gas facilities, compaction, removal of sheeting from the facilities, extra roadway base restoration and temporary pavement, associated maintenance and protection of traffic, barricades, and traffic plates that may be required to temporarily close and/or complete the work.

SECTION 6.07 - Test Pits For Gas Facilities.

1. Description:

Under this section, the Contractor shall furnish all labor, materials, insurance, equipment and appliances necessary to excavate, sheet and, maintain test pits at locations approved by the Resident Engineer in consultation with the facility operator. Test pits shall be dug in order to ascertain exact locations, cover and invert elevations, clearances, alignment and operating status (live or dead) of existing gas facilities. The Contractor shall inspect jointly with the Resident Engineer and facility operator, gas facilities and other structures uncovered, take all relevant measurements and elevations as directed by the Resident Engineer. Tests to determine operating status of gas facilities shall be performed by facility operator. The pits shall be covered with steel plates during daytime nonworking hours, and uncovered, as required, until the inspection work is completed. Testing of gas facilities may require a maximum of four (4) hours. Then, the pits shall be backfilled with clean fill, and resurfaced with temporary pavement. All traffic shall be maintained and all safety measures as stipulated shall be complied with.

2. Methods Of Construction:

A. **Excavation:** Existing pavement to be removed shall be neatly cut along lines of removal with a saw or other approved equipment which leaves a neat straight joint line along the juncture with subsequently replaced pavement. Excavation in the vicinity of utilities and other structures shall be performed using hand tools. Use of hand operated pneumatic and electric jackhammers will be permitted only for breaking pavement and removal of masonry, concrete and boulders, or as otherwise directed by the Resident Engineer. The Contractor shall properly dispose of all materials excavated from test pits away from site. Test pits shall be excavated at locations shown on the contract drawings or as directed by the Resident Engineer. Additional test pits may be required and shall be excavated where required, as ordered by the Resident Engineer. All test pits shall be excavated to a depth and size necessary to locate the existing facilities. Sheeting shall be used when depth of excavation exceeds five (5) feet. The sheeting required shall be furnished and installed in full compliance with the State of New York and Federal Safety Codes requirements and as specified in contract, whichever is more stringent. Care shall be taken that no existing gas facilities or other structures are broken or damaged. All broken or damaged facilities shall be reported immediately to facility operator who shall decide whether such facilities shall be repaired or replaced by company forces or by City contractor and in conformance with "General Provisions; Gas Cost Sharing Work Paragraph No. 9". Contractor shall excavate all material encountered, including large masses of concrete, cemented masonry and boulders, as directed by the Resident Engineer. Any type of excavation protection used, shall satisfy the following:

- (a) Industrial Code Rule 753.
- (b) Prevent injury to workers and the public, and avoid damage to existing water, sewer, and gas pipes or other structures, and to pavements and their foundations, through caving or sliding of the banks of the excavation.

Should it become necessary, as determined by the Resident Engineer, to enlarge any test pit in any dimension after sheeting has been placed, the Contractor shall remove portions of the sheeting, as necessary, enlarge the test pits as directed, and replace the sheeting without additional compensation for this work other than for the additional volume of material excavated.

B. **Maintenance Of Test Pits:** Excavated test pits shall be maintained free of debris and kept dry by the Contractor in order to permit the inspection and measurements and to determine the locations of facilities. In order to accomplish this, Contractor shall, upon completion of excavation and placement

of sheeting (if depth greater than five (5) feet), furnish and install adequate steel plates and posting over the excavated pits and shall temporarily remove all equipment debris and workers, and relocate barricades in order to open the full width of street to traffic during nonworking hours. The Contractor shall then, at no additional cost, relocate such barricades, barrels, cones and other warning devices and remove steel plates, as and when directed by the Resident Engineer to facilitate the inspection of exposed facilities. When work is being performed and the pits are not covered with steel plates, the Contractor shall provide complete and safe access to the test pits as may be required, and he shall provide construction barricades and maintain traffic at all times as shown or as directed by the Resident Engineer. Upon completion of test pit inspection by the Resident Engineer, the pit shall be backfilled by the Contractor as specified in contract, except that backfill material shall conform to contract specifications for such purpose.

- C. **Pavement And Sidewalk Restoration:** After backfilling is completed, the Contractor shall construct a temporary pavement consisting of a minimum of four (4) inches thick asphaltic concrete mixture in roadway areas or a two (2) inches thick asphaltic concrete mixture in sidewalk areas in order to maintain existing pedestrian and vehicular traffic. This temporary pavement shall be maintained until permanent pavement and sidewalk replacement is constructed as specified in contract.

3. Measurements:

The quantity to be measured for payment shall be the number of cubic yards of material removed from within the limits of the pit dimensions as directed by the Resident Engineer. The volume occupied by existing pipes or other structures remaining within the maximum payment lines will not be deducted from the total volume measured except, where the cross sectional area of these facilities exceeds four (4) square feet. As determined by the Resident Engineer, the quantity measured for payment may be proportionate to a fair and reasonable estimate of gas responsibility in the total volume excavated.

4. Price To Cover:

The contract price bid per cubic yard for test pits shall cover all additional costs of labor, material, insurance, equipment, appliances and incidentals required to excavate test pits, including removal and disposal of excavated materials, sheeting, steel plating, backfill, compaction and temporary pavement and sidewalk restoration all in accordance with the specifications and as directed by the Resident Engineer. The price shall also include the cost of providing safe access to the excavation by facility operator for the performance of certain test to determine operating status of gas facilities prior to City work. The price shall also include support and protection of all gas facilities crossing excavation, paralleling and/or encroaching any face of excavation.

SECTION 6.08 - "NO TEXT"

SECTION 6.09 - Trench Excavation and Backfill for New Gas Mains and Services (For National Grid Work Only)

1. Description:

Under this section, the contractor shall furnish all labor, materials, equipment, insurance, permits and incidentals required to break/remove roadway and sidewalk pavement, excavate, backfill and restore gas trenches. The trench to be excavated shall be determined by the size of the gas facility to be installed. The work shall be performed in accordance with applicable specifications, and/or at the direction of the Resident Engineer in consultation with the facility operator.

2. Materials:

All materials used to excavate and prepare trenches shall be supplied by the Contractor and be approved

by the facility operator in consultation with the Resident Engineer.

3. Method of Construction:

Excavation – The Contractor shall saw cut and/or break and remove existing roadway which may include but is not limited to, asphalt, concrete and cobblestone, utilizing approved equipment that leaves a neat straight joint line along the juncture with subsequently replaced pavement. Prior to starting the trenching operation, the contractor shall excavate the appropriate gas main tie-in pits at the extremities of the gas main sections to be replaced. Test pits shall be excavated to determine exact location of all tie-in pits and at appropriate intervals along proposed trench excavation to verify lane and clearances as shown on the contract plans. The tie-in pits shall be adequately protected by the contractor using wood fencing or steel traffic plates until such time when the facility operator has completed the tie-in work. The Contractor shall be permitted to excavate utilizing a combination of machine and hand excavation, as field conditions warrant, and as directed by the facility operator. The trench shall be adjusted so as to provide for a nominal cover on the new gas facilities or as required based on field conditions, applicable specifications, or as directed by the facility operator in consultation with the Resident Engineer. The width of the trench shall be as directed by the facility operator in consultation of the Resident Engineer. The bottom of the trench shall be graded smooth with a minimum cushion of 3 inches of clean sand and in conformance with applicable specification and be compacted, to minimize initial settlement and to avoid "point" support of new gas facilities. All stones projecting into the trench bottom shall be removed, and the voids backfilled before the new gas facilities are installed. Where streets are not to final grade, the cover shall be measured from the final grade, or the existing grade, whichever provides the deeper trench. Excavation in the vicinity of utilities and other structures shall be performed using hand tools. The contractor shall properly dispose of all materials excavated away from site. Size and location of excavation shall be as directed by the facility operator in consultation with the Resident Engineer. Trenches shall be excavated to a depth and size necessary to facilitate the installation of the new gas facility and in conformance with the applicable specification. All existing facilities that are encountered during trench excavating shall be protected in a manner suitable to the facility operator in consultation with the Resident Engineer. Tight sheeting shall be used, as required, based on field conditions and/or when the depth of excavation is equal to or greater than five feet. Skeleton type sheeting will not be permitted. The sheeting required shall be furnished and installed in full compliance with the State of New York and Federal Safety Code requirements and in compliance with applicable specifications and/or as directed by the facility operator in consultation with the Resident Engineer. Care shall be taken that no existing gas facilities or other structures are broken or damaged. Contractor shall excavate all material encountered necessary to facilitate the installation of the new gas facilities, and as directed by the facility operator. Care should be taken to avoid damage to existing utility facilities and structures, and to pavements and their foundations, and to avoid caving or sliding banks within the excavation.

Maintenance of Trench Excavation - Excavated trenches shall be maintained free of debris and kept dry by the contractor. In order to accomplish this, contractor shall, upon completion of excavation and placement of sheeting (as required and/or if depth is equal to or greater than five feet), furnish and install adequate steel plates, as directed by the facility operator in consultation with the Resident Engineer, and posting over the excavated trenches and shall temporarily remove all equipment debris and workers, and relocate barricades in order to open the full width of street to traffic during non-working hours, as required based on DOT requirements. National Grid forces will perform all live gas main connections, dead gas main cut-outs, and/or service work associated with disconnecting and reconnecting from old to new gas main. The Contractor shall then, at no additional cost, relocate such barricades barrels, cones and other warning devices and remove steel plates, as and when directed by the facility operator in consultation with the Resident Engineer to facilitate the installation of the new gas facilities. When work is being performed and the excavations are not covered with steel plates, the Contractor shall provide complete and safe access to the trench as may be required, and shall provide construction barricades and maintain traffic at all times as shown or as directed by the facility operator in consultation with the Resident Engineer. The contractor has the responsibility to maintain and set to grade all National Grid hardware during backfill and pavement restoration. Upon completion of installation of the new gas facility, the trench excavation shall be backfilled by the contractor in accordance with Contract requirements and all backfill material shall conform to contract specifications for such purpose.

Pavement and Sidewalk Restoration - After backfilling is completed, the contractor shall install temporary pavement consisting of six inches (6") thick asphaltic concrete mixture in roadway areas or a two inches (2") thick asphaltic concrete mixture in sidewalk areas in order to maintain existing pedestrian and vehicular traffic. This temporary pavement shall be maintained until permanent replacement as specified in contract. Permanent pavement restoration shall be as required by the appropriate contract specifications and as directed by the Resident Engineer.

4. Method of Measurement:

The quantity to be measured for payment shall be the number of cubic yards (C.Y.) of trench actually excavated, including roadway pavement, base and/or sidewalk concrete removed within the limits of the trench as directed by the Resident Engineer in consultation with the facility operator. The volume occupied by existing pipes or other structures will be deducted from the total volume measured as shown on contract drawing(s) Title: EP-7 SECT. 6.09 GAS SPECIALTY CONTRACTOR WORK, or as encountered based on existing field conditions.

5. Price to Cover:

The unit price bid per cubic yard for excavation shall include the cost of all supervision, labor, material, equipment, insurance and incidentals necessary to complete excavation trenches, including backfill, compaction testing and restoration of trenches and tie-ins pits as specified or shown on the contract, plans. The bid price shall also include the cost of coordinating the sewer and water main work to be performed by the contractor with the gas installation work to be performed by others. The price shall also include, associated maintenance of traffic, and traffic plates and openings and closings of plates as may be required in order to provide access to the facility operator during the new gas facility installation, and installing, removing and maintaining tight sheeting that may be required, cut, break and remove various thickness of surface and base pavement, excavate by hand, furnish, place and compact, in compliance with DOT requirements, clean sand backfill following installation of the gas facility. Any required removing, trucking, storing, and disposing of material shall be deemed included in the unit price. The price shall also include the cost of providing temporary pavement restoration. Permanent pavement restoration shall be deemed included in this item, as required and as directed by the Resident Engineer.

SECTION 6.09a Trench Excavation and Backfill for New Gas Mains and Services (For Con Edison Work Only)

1. Description:

Under this section, the contractor shall furnish all labor, materials, equipment, insurance, permits and incidentals required to break/remove roadway and sidewalk pavement, excavate, backfill and restore gas trenches. The trench to be excavated shall be determined by the size of the gas facility to be installed. The work shall be performed in accordance with applicable specifications, and/or at the direction of the Resident Engineer in consultation with the facility operator.

2. Materials:

All materials used to excavate and prepare trenches shall be supplied by the Contractor and be approved by the facility operator in consultation with the Resident Engineer. Clean sand backfill material shall be used and shall conform to Con Edison specification EO-1181-rev.6, General Specification for Backfilling of Trench and Small Openings.

3. Method of Construction:

Excavation - The Contractor shall saw cut and/or break and remove existing roadway which may include but is not limited to, asphalt, concrete and cobblestone, utilizing approved equipment that leaves a neat straight joint line along the juncture with subsequently replaced pavement. Prior to starting the trenching operation, the contractor shall excavate the appropriate gas main tie-in pits at the extremities of the gas main sections to be replaced. Test pits shall be excavated to determine exact location of all tie-in pits and

at appropriate intervals along proposed trench excavation to verify lane and clearances as shown on the contract plans. The tie-in pits shall be adequately protected by the contractor using wood fencing or steel traffic plates until such time when the facility operator has completed the tie-in work. The Contractor shall be permitted to excavate utilizing a combination of machine and hand excavation, as field conditions warrant, and as directed by the facility operator. The trench shall be adjusted so as to provide for a nominal cover on the new gas facilities or as required based on field conditions, applicable specifications, or as directed by the facility operator in consultation with the Resident Engineer. The width of the trench shall be as directed by the facility operator in consultation of the Resident Engineer. The width and depth of the trench shall conform to Con Edison Gas Operations drawing 309495 rev. 4, Trench Excavation for Gas Mains Up to 350 PSIG, or as directed by the facility operator in consultation of the Resident Engineer. The bottom of the trench shall be graded smooth with a minimum cushion of 3 inches of clean sand and in conformance with applicable specification and be compacted, to minimize initial settlement and to avoid "point" support of new gas facilities. All stones projecting into the trench bottom shall be removed, and the voids backfilled before the new gas facilities are installed. Where streets are not to final grade, the cover shall be measured from the final grade, or the existing grade, whichever provides the deeper trench. Excavation in the vicinity of utilities and other structures shall be performed using hand tools. The contractor shall properly dispose of all materials excavated away from site. Size and location of excavation shall be as directed by the facility operator in consultation with the Resident Engineer. Trenches shall be excavated to a depth and size necessary to facilitate the installation of the new gas facility and in conformance with the applicable specification. All existing facilities that are encountered during trench excavating shall be protected in a manner suitable to the facility operator in consultation with the Resident Engineer. Tight sheeting shall be used, as required, based on field conditions and/or when the depth of excavation is equal to or greater than five feet. Skeleton type sheeting will not be permitted. The sheeting required shall be furnished and installed in full compliance with the State of New York and Federal Safety Code requirements and in compliance with applicable specifications and/or as directed by the facility operator in consultation with the Resident Engineer. Care shall be taken that no existing gas facilities or other structures are broken or damaged. Contractor shall excavate all material encountered necessary to facilitate the installation of the new gas facilities, and as directed by the facility operator. Care should be taken to avoid damage to existing utility facilities and structures, and to pavements and their foundations, and to avoid caving or sliding banks within the excavation.

Maintenance of Trench Excavation - Excavated trenches shall be maintained free of debris and kept dry by the contractor. In order to accomplish this, contractor shall, upon completion of excavation and placement of sheeting (as required and/or if depth is equal to or greater than five feet), furnish and install adequate steel plates, as directed by the facility operator in consultation with the Resident Engineer, and posting over the excavated trenches and shall temporarily remove all equipment debris and workers, and relocate barricades in order to open the full width of street to traffic during non-working hours, as required based on DOT requirements. Con Edison forces will perform all live gas main connections, dead gas main cut-outs, and/or service work associated with disconnecting and reconnecting from old to new gas main. The Contractor shall then, at no additional cost, relocate such barricades barrels, cones and other warning devices and remove steel plates, as and when directed by the facility operator in consultation with the Resident Engineer to facilitate the installation of the new gas facilities. When work is being performed and the excavations are not covered with steel plates, the Contractor shall provide complete and safe access to the trench as may be required, and shall provide construction barricades and maintain traffic at all times as shown or as directed by the facility operator in consultation with the Resident Engineer. The contractor has the responsibility to maintain and set to grade all Con Edison hardware during backfill and pavement restoration. Upon completion of installation of the new gas facility, the trench excavation shall be backfilled by the contractor in accordance with Contract requirements and all backfill material shall conform to contract specifications for such purpose.

Pavement and Sidewalk Restoration - After backfilling is completed, the contractor shall install temporary pavement consisting of six inches (6") thick asphaltic concrete mixture in roadway areas or a two inches (2") thick asphaltic concrete mixture in sidewalk areas in order to maintain existing pedestrian and vehicular traffic. This temporary pavement shall be maintained until permanent replacement as specified in contract. Permanent pavement restoration shall be as required by the appropriate contract specifications and as directed by the Resident Engineer.

4. Method of Measurement:

The quantity to be measured for payment shall be the number of cubic yards (C.Y.) of trench actually excavated, including roadway pavement, base and/or sidewalk concrete removed within the limits of the trench as directed by the Resident Engineer in consultation with the facility operator. The volume occupied by existing pipes or other structures will be deducted from the total volume measured as shown on contract drawing(s) Title: EP-7 SECT. 6.09 GAS SPECIALTY CONTRACTOR WORK, or as encountered based on existing field conditions.

5. Price to Cover:

The unit price bid per cubic yard for excavation shall include the cost of all supervision, labor, material, equipment, insurance and incidentals necessary to complete excavation trenches, including backfill, compaction testing and restoration of trenches and tie-ins pits as specified or shown on the contract, plans. The bid price shall also include the cost of coordinating the sewer and water main work to be performed by the contractor with the gas installation work to be performed by others. The price shall also include, associated maintenance of traffic, and traffic plates and openings and closings of plates as may be required in order to provide access to the facility operator during the new gas facility installation, and installing, removing and maintaining tight sheeting that may be required, cut, break and remove various thickness of surface and base pavement, excavate by hand, furnish, place and compact, in compliance with DOT requirements, clean sand backfill following installation of the gas facility. Any required removing, trucking, storing, and disposing of material shall be deemed included in the unit price. The price shall also include the cost of providing temporary pavement restoration. Permanent pavement restoration shall be deemed included in this item, as required and as directed by the Resident Engineer.

SECTION 6.06A - Special Care Excavation and Backfilling for Transmission Mains. (Transmission Main is described as any gas main with a MAOP greater than 124 psig)

1. Description:

Under this section, the contractor shall provide all labor, materials (except for sand to be utilized for backfill of a one foot envelope around the facility to be furnished by the facility operator), equipment, and incidentals required to support and protect the integrity of Gas Transmission Main during excavations. This facility is owned by the gas company operating in the area, hereafter referred to as facility operator. The work shall be performed in accordance with the contract plans, specifications and at the directions of the Resident Engineer in consultation with authorized representatives of the facility operator.

2. Applicability of Section:

This section shall apply to Transmission Main of various sizes located within any excavation sheeted or unsheeted (excavation refers to any excavation performed for city work and includes excavations performed that are to be subsequently unsheeted/sheeted using approved shoring methods and paralleling, encroaching and crossing any excavation. Parallel facilities are not exposed at any time during excavation (within 2' of edge of excavation)). Encroaching facilities are partially/fully exposed inside the limit of excavation. This section shall also apply to gas facility crossing catch basins excavation and catch basins sewer connections (chutes), water mains, fire hydrant branch connections, sanitary sewer, storm sewer, combination sewer, house sewer and/or water service connections excavations. The excavation around fully exposed live gas facilities along and within limits of excavation shall be covered by this section also, however the support requirement, if any is required, of such facilities is beyond the scope of these specifications and therefore shall be the responsibility of facility operator to determine and prescribe, at no cost to the City contract, but shall be a matter of adjustment between the contractor and facility operator.

3. Payment Restriction:

The bid item specified under this section shall not be used in combination with items covered under other sections for work done due to a particular gas facility. This item shall not be paid for new gas facilities when trenching for such new facilities has been performed by the contractor of record in common with trench excavation for City Work (overlapping trench limits). The cost of excavating with care as defined in this section shall be deemed included in the cost of trench excavation for the new gas facilities. This restriction shall apply even if such gas common trench excavation is not part of the contract. If facilities are in direct interference with City work, meaning that "minimum clearances" described in the General Provisions for Gas Cost Sharing (Para. No.8) cannot be maintained, the excavation shall be abandoned and the contractor shall be compensated as per the provisions specified in Paragraphs Nos. 5 and 6 of this item (6.06A).

4. Method of Construction:

All excavations in the vicinity of gas facilities shall be as required by NYS Industrial Code 753. No saw cutting of pavement or masonry for gas mains having less than 2 feet of cover to break asphalt/concrete as determined by the facility operator. The contractor shall use power excavation for the removal

of pavement or masonry but only to the depth of such pavement or masonry (breaking of pavement or masonry shall be done by means of hand held pneumatic breaking equipment). Upon removal of pavement or masonry the contractor shall use hand excavation methods only (pick and shovel; no power tools) to ascertain the clearances of these facilities with respect to the proposed excavation. Once the location of these facilities with respect to the proposed excavation is verified to the satisfaction of the Resident Engineer and the facility operator the contractor shall then proceed with hand only within the zone of protection described as 2 feet from the face of the facility in all directions of the facility as required to preserve the integrity of the facility. Once outside of the zone of protection as described above the contractor may use a combination of hand and machine to complete the excavation.

5. Method of Payment:

The unit price for this work item shall be based on cubic yard (CY) of average excavation with special care and, is to be considered as an incremental cost for performing City work with gas facilities interferences.

6. Method of Measurement: A.

For Paralleling Facilities:

Volume calculated as: Depth as measured from existing street surface to the bottom of facility, multiplied by, the width measured as two (2) feet from the face of excavation toward the center of excavation, multiplied by the length of parallel facility, divided by twenty-seven (27) cubic feet per cubic yard Only hand excavation shall be utilized within the zone of protection identified as 2 feet from face of facility, beyond 2 feet from the face of facility the contractor can use a combination of hand and machine.

B. For Encroaching Facilities:

Volume calculated as: Depth as measured from existing street surface to the bottom of facility, multiplied by, the width measured as two (2) feet plus the exposed facility toward the center of excavation, multiplied by the length of the encroached facility, divided by twenty-seven (27) cubic feet per cubic yard Only hand excavation shall be utilized within the zone of protection identified as 2 feet from face of facility, beyond 2 feet from the face of facility the contractor can use a combination of hand and machine.

C. Fully Exposed Gas Facilities:

Volume calculated as: Depth as measured from existing street surface to the bottom of facility, multiplied by, the width measured as two (2) feet from the face of the facility on either side plus the facility, multiplied by the length of the facility, divided by 27 cubic feet per cubic yard. Only hand excavation shall be utilized within the zone of protection identified as 2 feet from face of facility in all directions, beyond 2 feet from the face of facility in all directions the contractor can use a combination of hand and machine.

D. For Additional Excavation And Restoration Due To So Called "Loss Trench", When The Integrity Of Pavement And Soil Above And Around Existing Live Gas Facilities Cannot Be maintained Due To Its Lack of Cohesiveness:

Volume shall be calculated as: Depth of unsheeted trench excavation multiplied by width measured as distance of facility from closest edge of unsheeted excavation plus, width of facility proper plus, one (1) foot or a maximum width of three (3) feet multiplied by length of facility fully exposed divided by, twenty-seven (27) cubic feet per cubic yard (not shown on "Gas Cost Sharing Work Standard Sketch No. 5").

- E. For Facilities Crossing Excavation For Catch Basins, Or Chutes Installations (When NYCDEP Funded) Or Fire Hydrant Branch Connections, Or Unsheeted Water Main Trench, Or House Sewer And/Or Water Services:

Volume calculated as: Depth as defined above multiplied by, the width taken as the outside diameter of pipe or the width of structure plus one (1) foot on either side (two (2) feet), multiplied by, the length of exposed facility crossing the trench, divided by twenty-seven (27) cubic feet per cubic yard (not shown on "Gas Cost Sharing Work Standard Sketch No.5").

7. Price to Cover:

The bid price shall also cover all additional supervision, labor, material, equipment and insurance necessary to excavate while protecting and maintaining (excluding supports for fully exposed live gas) gas facilities without disruption of service to the public and in accordance with contract specifications. The price shall also include, changes of sheeting method and excavation width configuration where necessary to accommodate gas facilities in their existing locations; difficulties during the installation of catch basins, chute connections, hydrant branch, and house sewer, sanitary sewer, storm sewer, combination sewer and water connections under or over gas facilities; loss of productivity due to slower rate of excavation (special care) during excavation, compaction, removal of sheeting from the facilities, extra roadway base restoration and temporary pavement, associated maintenance of traffic, barricades, and traffic plates that may be required to temporarily close and/or complete the work. Breaking shall be done by means of hand held pneumatic breaking equipment. Inspection of exposed mains shall be performed by facility operator in a timely fashion and shall not unduly impede contractor's progress or productivity.

GAS COST SHARING STANDARD SPECIFICATIONS
SCHEDULE GCS-A

Average rate charged by utility companies to Disconnect and Reconnect Gas Services:

- 1. National Grid - \$586.90 per Service/and Visit
- 2. Con Edison - \$524.00 per Service/and Visit

IV - STANDARD SKETCHES; GAS COST SHARING WORK

Hereinafter attached are the following Standard Sketches for Gas Cost Sharing Work:

- Sketch No. 1 - Support Requirements For Gas Mains And Services Crossing Excavation Greater Than 4' - 0" Wide At Any Angle**
- Sketch No. 1A - Support Requirements For Gas Mains Over 16" Diameter Up To And Including 48" Diameter Crossing Excavation At Any Angle**
- Sketch No. 2 - Typical Methods Of Measurement For Gas Crossings**
- Sketch No. 3 - Utility Crossings During Catch Basin Chute Connection Pipe Installation**
- Sketch No. 4 - Utility Crossings During Catch Basin Chute Connection Pipe Installation (Extra Depth)**
- Sketch No. 5 - Gas Main Encroachment On And/Or Parallel To Excavation Of Unsheeted Trench**

GAS COST SHARING WORK (SKETCH NO. 1)

SUPPORT REQUIREMENTS FOR GAS MAINS AND SERVICES CROSSING EXCAVATION GREATER THAN 4'-0" WIDE AT ANY ANGLE

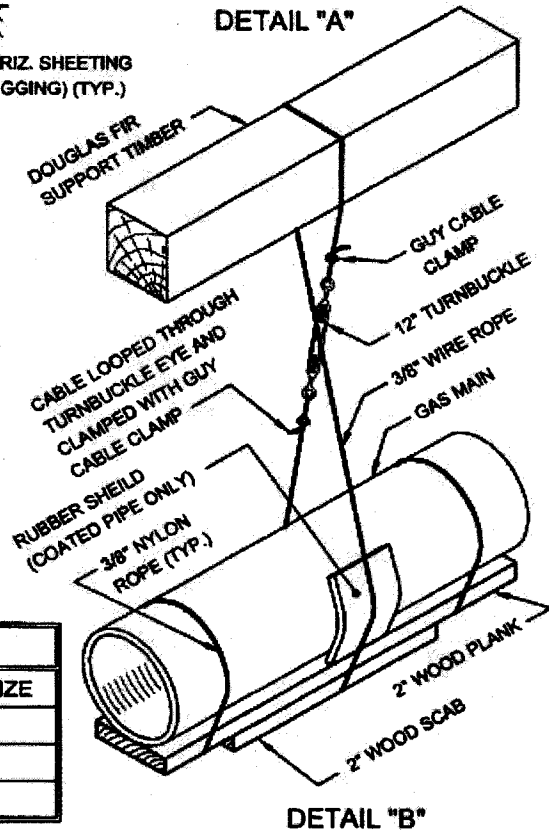
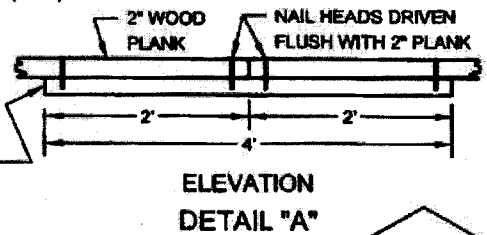
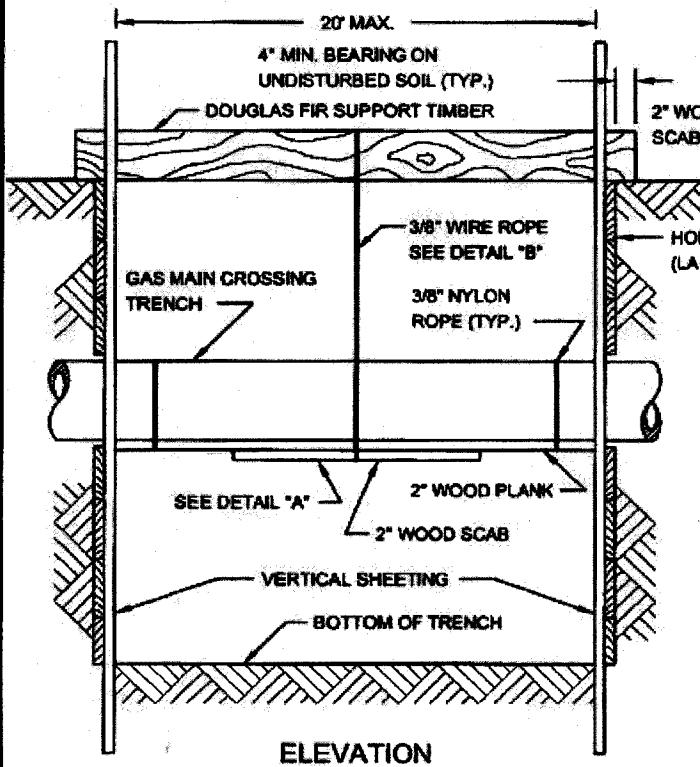
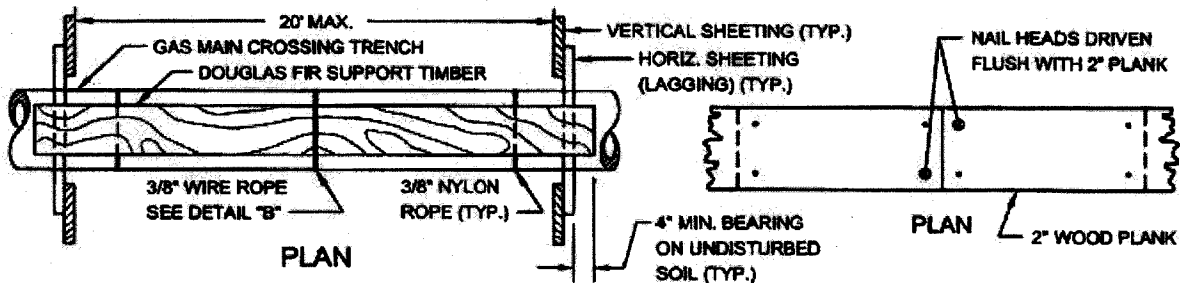

CABLE SUPPORT		TIMBER SUPPORT	
MAIN TYPE	SPACING	MAIN SIZE	TIMBER SIZE
CAST IRON	4' O.C. MAX.	UP TO 6"	6" X 6"
STEEL	10' O.C. MAX.	8" TO 10"	8" X 8"
PLASTIC	10' O.C. MAX.	12" TO 16"	10" X 10"

REVISIONS: 2004 - L. ADRIAN
REVISED JUNE 1988 - J. WONG / W. PATACKO / P. BOY

GAS COST SHARING WORK (SKETCH NO. 1A)
SUPPORT REQUIREMENTS FOR GAS MAINS OVER 16" DIAMETER UP TO AND INCLUDING 48" DIAMETER CROSSING EXCAVATION AT ANY ANGLE

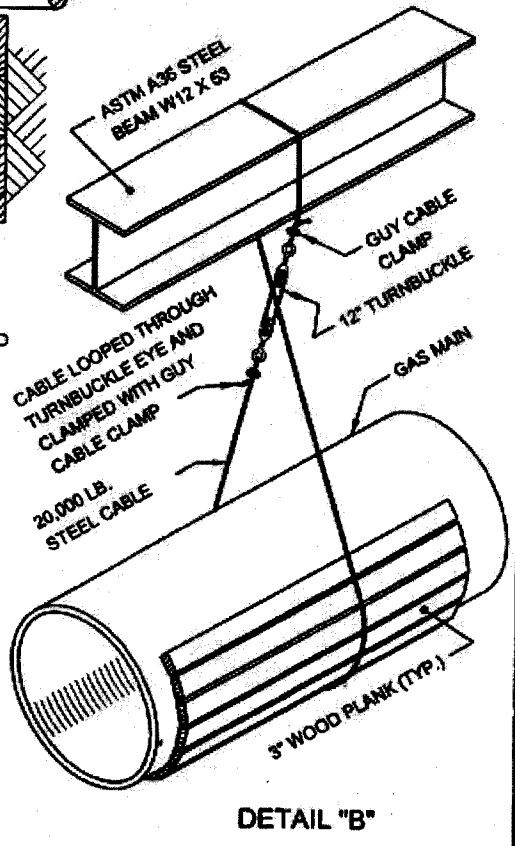
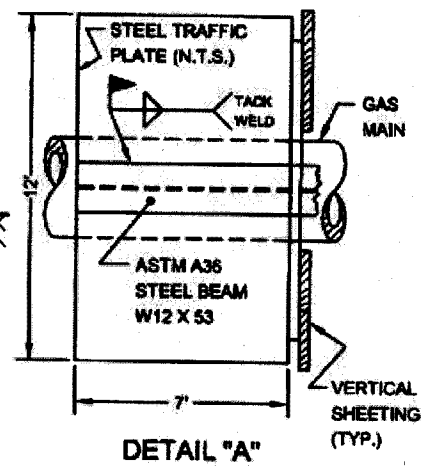
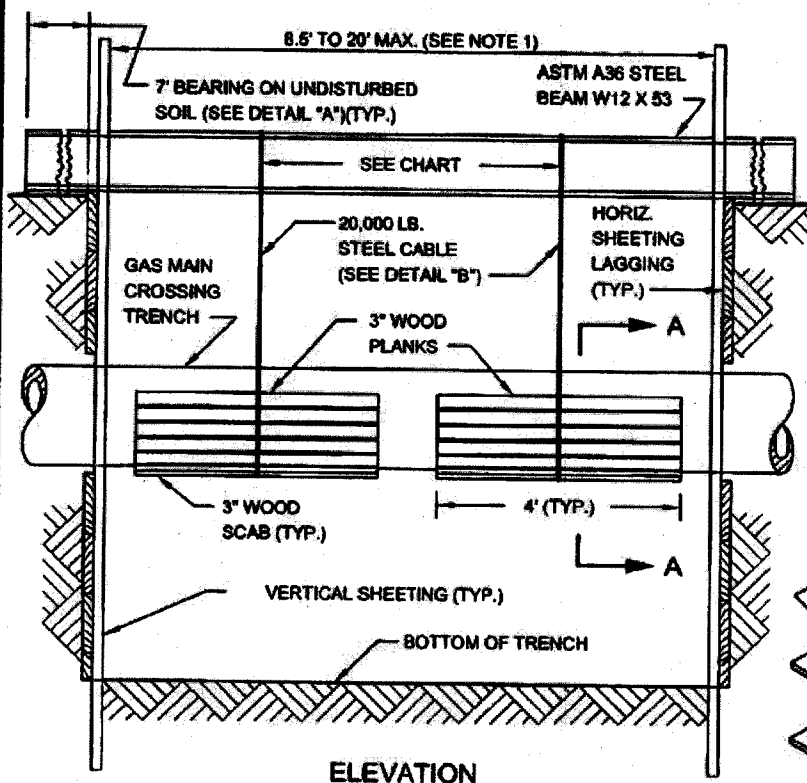

CABLE SUPPORT	
MAIN TYPE	SPACING
CAST IRON	4' O.C. MAX.
STEEL	10' O.C. MAX.

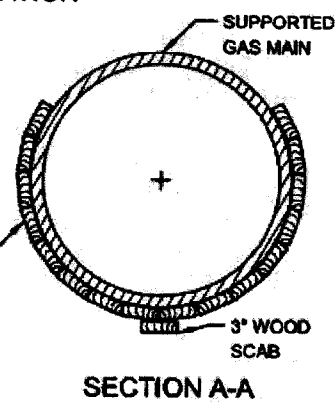

- NOTES:**
- (1) NO SUPPORT IS REQUIRED FOR GAS MAINS OVER 16" DIA. UP TO AND INCLUDING 48" DIA. CROSSING TRENCHES LESS THAN 8.5' WIDE.
 - (2) UNDERMINE A MAXIMUM OF 8.5 L.F. OF CAST IRON GAS MAIN AT A TIME.
 - (3) SET STEEL CABLE OVER 3" WOOD PROTECTIVE PLANKS AND PLACE AN ADDITIONAL 3" SCAB ON THE BOTTOM OF THE GAS MAIN.
 - (4) ADJUST STEEL CABLE UNTIL DEAD WEIGHT OF THE UNDERMINED GAS MAIN HAS BEEN TAKEN UP BY THE OVERHEAD STEEL BEAM SUPPORT.
 - (5) ALL SUPPORTS AND STEEL CABLES CAN BE REMOVED ONLY AFTER THE REQUIRED BACKFILL (AROUND AND BELOW GAS MAIN) HAS BEEN COMPACTED IN ACCORDANCE WITH NEW YORK CITY STANDARDS AND AT THE DIRECTIONS OF THE ENGINEER.

REVISED OCT. 2014 - L. ANDERSON
 REVISED JUNE 1988 - J. WARD/ W. PATRICKSON, INC.

GAS COST SHARING WORK (SKETCH NO. 2)
TYPICAL METHODS OF MEASUREMENT FOR GAS CROSSINGS

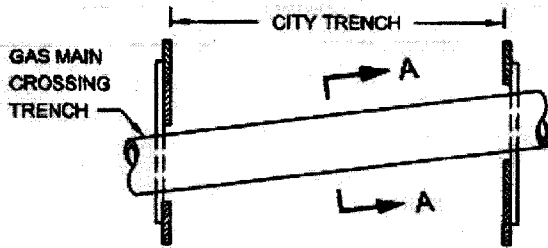

SINGLE FACILITY CROSSING

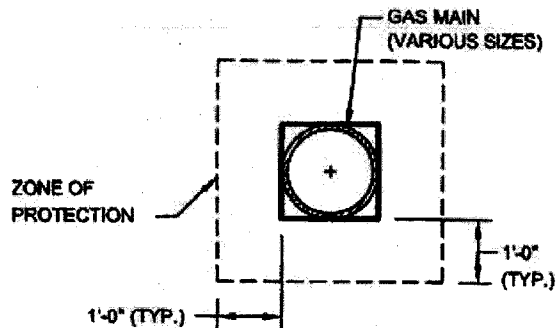

SECTION A-A

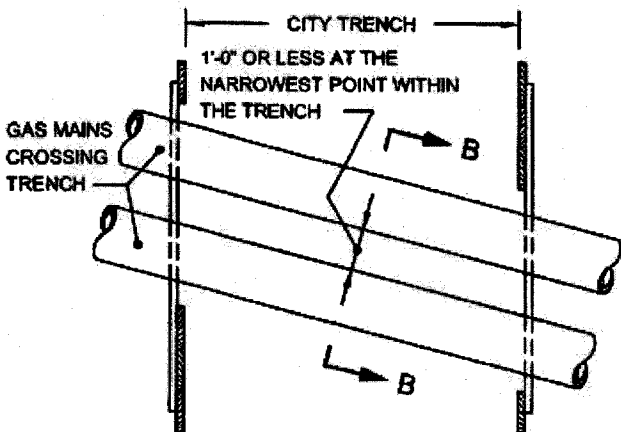

**MULTIPLE FACILITIES
(GAS MAINS AT SAME ELEVATION)**

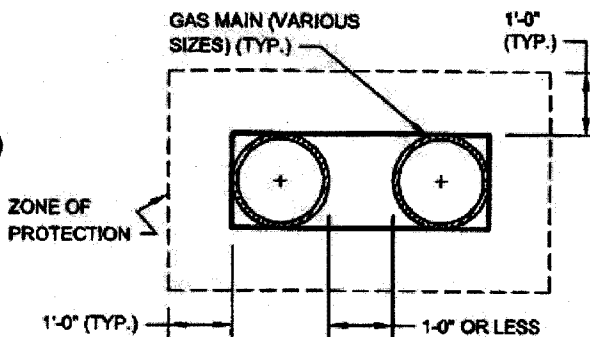

SECTION B-B

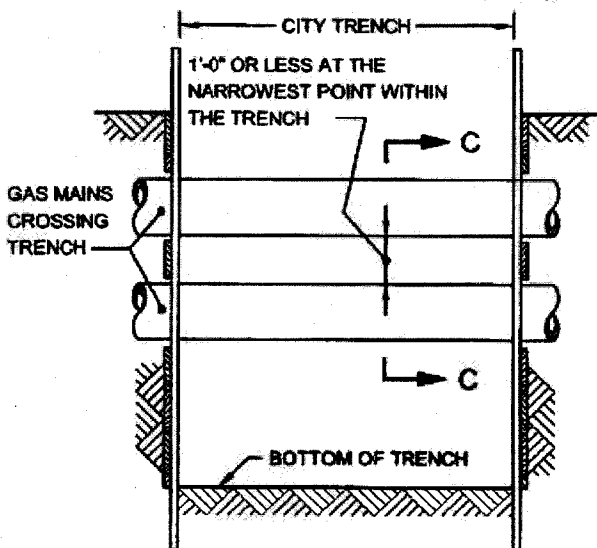

**MULTIPLE FACILITIES
(ONE CROSSING AT DIFFERENT ELEVATIONS)**

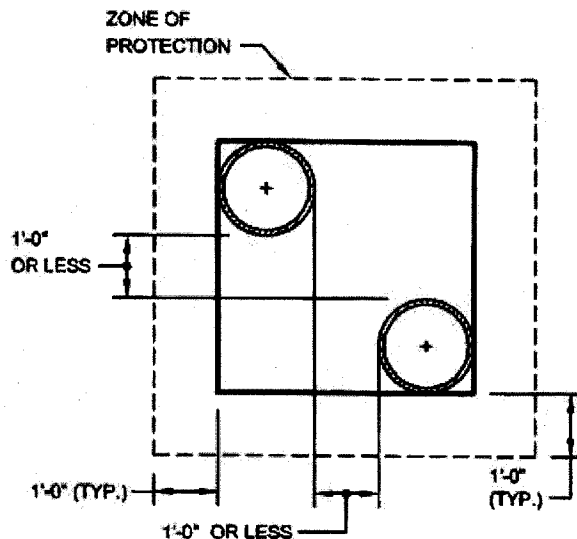

SECTION C-C

NOTE:

GAS MAINS MAY OR MAY NOT BE PARALLEL TO EACH OTHER.

REVISED SEPT. 2004 - L. ADRIEN
 REVISED SEPT. 2004 - J. WONGAW, PATALANOP, MOY

GAS COST SHARING WORK (SKETCH NO. 3) UTILITY CROSSINGS DURING CATCH BASIN CHUTE CONNECTION PIPE INSTALLATION

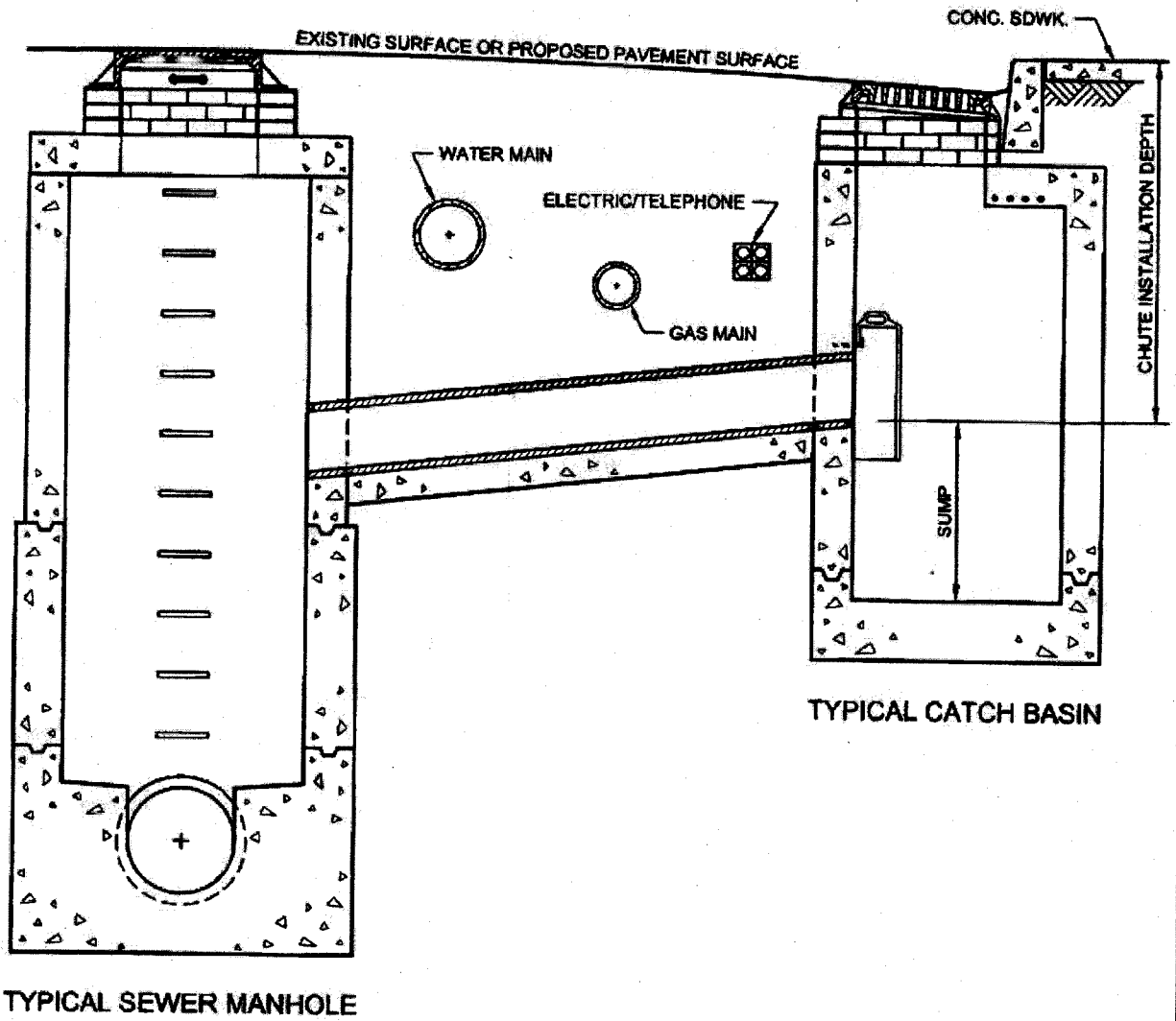

REVISED OCT. 2004 BY J.L. GOSWAMI
REVISED OCT. 1988 BY J. WORSWICK, PNTALANDIP, INC.

GAS COST SHARING WORK (SKETCH NO. 4)
UTILITY CROSSINGS DURING CATCH BASIN CHUTE
CONNECTION PIPE INSTALLATION (EXTRA DEPTH)

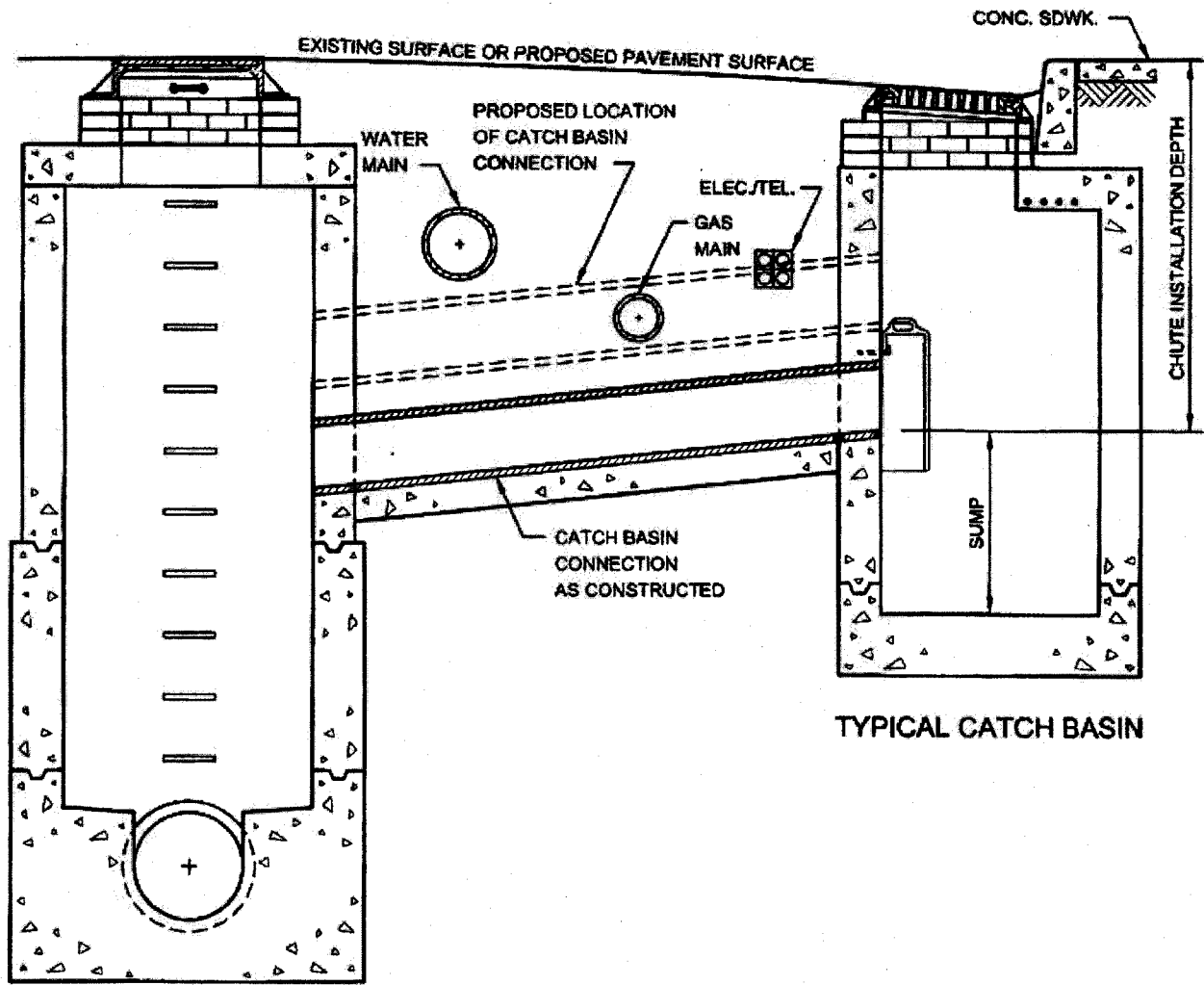

TYPICAL SEWER MANHOLE

TYPICAL CATCH BASIN

REVISED OCT. 2004 - L. AUBRIEN
 REVISED OCT. 1986 - J. WONGWAI, PATTANAPORN, MOY

GAS COST SHARING WORK (SKETCH NO. 5)
GAS MAIN ENCROACHMENT ON AND/OR PARALLEL
TO EXCAVATION OF UNSHEETED TRENCH

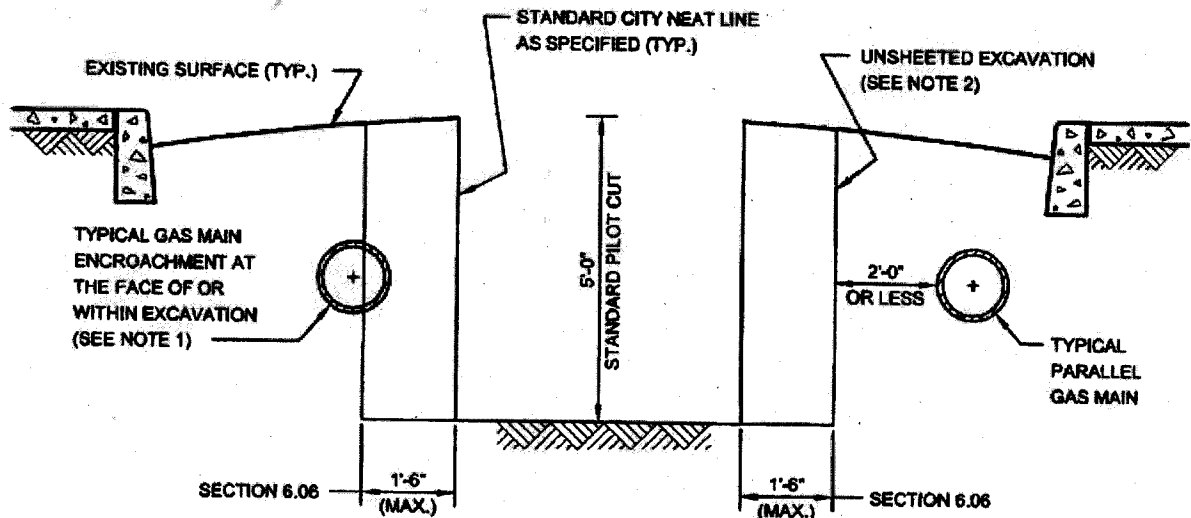

NOTES:

- (1) GAS MAIN LOCATED AS SHOWN MAY HAVE TO BE REMOVED BY THE FACILITY OPERATOR PRIOR TO THE START OF CITY EXCAVATION, OTHERWISE, THE CONTRACTOR WILL BE PAID UNDER SECTION 6.06 FOR THE SAID WORK. IF GAS MAIN IS ABANDONED THEN SECTION 6.03 SHALL APPLY.
- (2) EIGHTEEN (18) INCHES FROM STANDARD NEAT LINE IS THE MAXIMUM ALLOWABLE WIDTH OF AREA THAT MAY BE DISTURBED OR EXCAVATED DURING INSTALLATION OF CERTAIN TYPES OF SHEETING SYSTEMS THAT MEET THE REQUIREMENTS OF THE STANDARD SPECIFICATIONS OF THE DEPARTMENT OF DESIGN AND CONSTRUCTION OF THE CITY OF NEW YORK.

REVISED OCT. 2004 - J. ADRIEN
 REVISED OCT. 1998 - J. WORTHAM, PATAJANDOP, MOY

V - PRELIMINARY GAS WORK TO BE PERFORMED BY FACILITY OPERATOR

APPLICABLE TO ALL GAS DRAWINGS:

- ALL RELOCATION WORK SHOWN IN THIS SECTION IS TO BE PERFORMED BY FACILITY OPERATOR.
- ALL SUPPORT AND PROTECTION WORK IS TO BE PERFORMED BY CITY CONTRACTOR.
- IF ADDITIONAL INFORMATION IS NEEDED REGARDING THE FACILITY OPERATOR RELOCATION WORK, THE CONTRACTOR IS ADVISED TO CONTACT THE GAS COMPANY REPRESENTATIVE:

O'NEILL A. WRIGHT
CONSOLIDATED EDISON
4 IRVING PL. 12TH FLOOR
NEW YORK, NY 10003
212-460-3870

NEVILLE JACOBS
NATIONAL GRID
287 MASPETH AVENUE
BROOKLYN, NY 11211
TEL.: 718-963-5612

(NO TEXT IN THIS AREA, TURN PAGE)

EP7-27

VI - LISTING OF APPROXIMATE LOCATIONS OF EP-7 BID

ITEMS QUANTITIES

(NO TEXT IN THIS AREA, TURN PAGE)

**SCOPE OF WORK
SUPPORT AND PROTECTION
FOR CONTRACT NUMBER SEQBN11**

The City of New York Department of Design and Construction is planning to install sewers and/or water mains and all appurtenances in various locations in The City of New York along with all work incidental thereto.

6.01.1 (CE) - Gas Main Crossing Sewer Up To 24" In Diameter (Ea.)

2 in Various Locations As Required

6.01.2 (CE) - Gas Main Crossing Sewer 30" In Diameter (Ea.)

2 in Various Locations As Required

6.01.3 (CE) - Gas Main Crossing Sewer 36" Thru 42" In Diameter (Ea.)

2 in Various Locations As Required

6.01.4 (CE) - Gas Main Crossing Sewer 48" Thru 54" In Diameter (Ea.)

2 in Various Locations As Required

6.01.8 (CE) - Gas Services Crossing Trenches And/Or Excavations (Ea.)

2 in Various Locations As Required

6.01.9 (CE) - Gas Main Crossing Water Main Up To 20" In Diameter (Ea.)

2 in Various Locations As Required

6.02 (CE) - Extra Excavation For The Installation Of Catch Basin Sewer Drain Pipes With Gas Interferences (Ea.)

10 in Various Locations As Required

6.03 (CE) - Removal Of Abandoned Gas Facilities. All Sizes (L.F.)

1,000 in Various Locations As Required

**SCOPE OF WORK
SUPPORT AND PROTECTION
FOR CONTRACT NUMBER SEQBN11**

The City of New York Department of Design and Construction is planning to install sewers and/or water mains and all appurtenances in various locations in The City of New York along with all work incidental thereto.

**6.03.1a (CE) - Removal Of Abandoned Gas Facilities With Possible Coal Tar Wrap.
All Sizes. (For Con Edison Work Only) (L.F.)**

100 in Various Locations As Required

6.04 (CE) - Adjust Hardware To Grade Using Spacer Rings / Adaptor (Street Repaving) (Ea.)

50 in Various Locations As Required

6.05 (CE) - Adjust Hardware To Grade By Resetting (Road Reconstruction) (Ea.)

50 in Various Locations As Required

6.06 (CE) - Special Care Excavation & Backfilling (C.Y.)

500 CY In Various Locations As Required, Including But Not Limited
To All Gas Services Crossing Unsheeted Water Main Trenches.

6.07 (CE) - Test Pits For Gas Facilities (C.Y.)

100 in Various Locations As Required.

**6.09a (CE) - Trench Excavation & Backfill For New Gas Mains & Services. Gas Installed By
Others. (For Con Edison Work Only) (C.Y.)**

100 in Various Locations As Required

EP7-28B

**SCOPE OF WORK
SUPPORT AND PROTECTION
FOR CONTRACT NUMBER SEQBN11**

The City of New York Department of Design and Construction is planning to install sewers and/or water mains and all appurtenances in various locations in The City of New York along with all work incidental thereto.

6.01.1 (NG) - Gas Main Crossing Sewer Up To 24" In Diameter (Ea.)

30 in Various Locations As Required

6.01.2 (NG) - Gas Main Crossing Sewer 30" In Diameter (Ea.)

2 in Various Locations As Required

6.01.3 (NG) - Gas Main Crossing Sewer 36" Thru 42" In Diameter (Ea.)

3 in Various Locations As Required

6.01.4 (NG) - Gas Main Crossing Sewer 48" Thru 54" In Diameter (Ea.)

2 in Various Locations As Required

6.01.8 (NG) - Gas Services Crossing Trenches And/Or Excavations (Ea.)

400 in Various Locations As Required

6.01.9 (NG) - Gas Main Crossing Water Main Up To 20" In Diameter (Ea.)

8 in Various Locations As Required

6.02 (NG) - Extra Excavation For The Installation Of Catch Basin Sewer Drain Pipes With Gas Interferences (Ea.)

80 in Various Locations As Required

6.03 (NG) - Removal Of Abandoned Gas Facilities. All Sizes (L.F.)

2,000 in Various Locations As Required

EP7.28C

**SCOPE OF WORK
SUPPORT AND PROTECTION
FOR CONTRACT NUMBER SEQBN11**

The City of New York Department of Design and Construction is planning to install sewers and/or water mains and all appurtenances in various locations in The City of New York along with all work incidental thereto.

**6.03.1 (NG) - Removal Of Abandoned Gas Facilities With Possible Coal Tar Wrap.
All Sizes. (For National Grid Work Only) (L.F.)**

300 in Various Locations As Required

6.04 (NG) - Adjust Hardware To Grade Using Spacer Rings / Adaptor (Street Repaving) (Ea.)

30 in Various Locations As Required

6.05 (NG) - Adjust Hardware To Grade By Resetting (Road Reconstruction) (Ea.)

30 in Various Locations As Required

6.06 (NG) - Special Care Excavation & Backfilling (C.Y.)

1,300 CY in Various Locations As Required, Including But Not Limited
To All Gas Services Crossing Unsheeted Water Main Trenches.

6.06a (NG) - Special Care Excavation & Backfilling For Transmission Mains (C.Y.)

50 CY in Various Locations As Required, Including But Not Limited
To All Gas Services Crossing Unsheeted Water Main Trenches And The Following
Locations:

6.07 (NG) - Test Pits For Gas Facilities (C.Y.)

100 in Various Locations As Required

6.09 (NG) - Trench Excavation & Backfill For New Gas Mains & Services. (C.Y.)

50 in Various Locations As Required

EP-7 (2.0)

EP-7

END OF EP-7 PAGES

**THE EP-7 PAGES CONSIST OF FORTY-FOUR (44) PAGES,
INCLUDING THIS PAGE.**

U - PAGES

SECTION U (VERSION 2.0)

NOTICE

THE PAGES CONTAINED IN THIS SECTION U VERSION 2.0 (U-PAGES) REPRESENT ADDITIONAL CONTRACT REQUIREMENTS APPLYING TO WORK PERFORMED IN THE PRESENCE OF PRIVATELY OWNED UTILITY FACILITIES.

(NO TEXT ON THIS PAGE)

SECTION U (VERSION 2.0)

DATED: September 16, 2019

1. The Contractor shall be responsible for compliance with all the provisions of the following Sections and Schedules, which are hereby made a part of the original contract documents:
 - A. "SECTION U: Additional Contract Requirements Applying to Work Performed in the Presence of Privately Owned Utility Facilities" (Pages U-3 through U-13)
 - B. Schedule U-1 (Page U-15)
 - C. Schedule U-2 listing scope of utility interferences is no longer included in City contract. Such information will be part of Interference Agreement between Utility Operator and the Contractor.
 - D. Schedule U-3 Page U-16 (as per the Private Utilities reference document for SECTION U called "CET SPECIFICATIONS AND SKETCHES", dated November 2010).
2. Each facility operator shall provide inspectors at the work site to inspect methods of interference work, verify quantities and items of Utility Work, and coordinate all phases of the facility operator operations.
3. In addition, the following statements are made to provide clarification of various paragraphs under Section U:
 - A. Section U, Paragraph 3, requires the Contractor to immediately commence negotiations with each Company for an Interference Agreement under which the Company will compensate the Contractor for any Interference Work which the Company does not elect to perform with its own forces or by specialty contractors retained by the Company. Thus the Contractor is on notice that its work under the Contract may be affected by Interference Work performed by (a) the Contractor pursuant to a separate Interference Agreement with the Company, (b) the Company, or (c) partly by each.

- B. The City has no contract with any of the Companies for work on or adjacent to the site of work under this Contract, and the Companies are not "Other Contractors" as defined for the purposes of this Contract. The Contractor is reminded, however, that pursuant to Section U, Paragraph 3, the City will not compensate the Contractor for any direct and/or indirect costs related to Interference Work, regardless of whether such Interference Work is covered by an Interference Agreement between the Contractor and the Company or is performed by the Company using its own forces or by specialty contractors retained by the Company.
- C. Section U, Paragraph 13, provides that the provisions of Section U are material provisions of the Contract and that the Contractor's failure to comply with the procedures set forth in Section U are sufficient for the Commissioner to declare the Contractor in default pursuant to Article 48 of the Contract.

Pursuant to this Section, the Contractor is informed that the Performance Bond required of the Contractor pursuant to the Contract is not deemed to guarantee performance of any of the Interference Work.

Section U: Additional Contract Requirements Applicable to Work Performed in the Presence of Privately Owned Utility Facilities

The Contractor is hereby notified that pursuant to the law and franchise agreements issued by the City, certain private utility and public service companies named in Schedule U-1 ("the Companies") own and/or operate surface and/or subsurface facilities within the limits of this contract. The existence of these facilities impacts the productivity of the City work called for in the contract. In order to improve coordination of the City construction with the private utility facilities owned and/or operated by the Companies named in Schedule U-1, Article 1.06.30 of the Standard Highway Specifications of the New York City Department of Transportation, Dated August 1, 2015; and/or Articles 10.15 through 10.18 of the Standard Sewer and Water Main Specifications of the New York City Department of Environmental Protection, Dated July 1, 2014; as applicable, are amended and will be implemented as follows:

1. Means and methods for City work:

- a) The Contractor is hereby notified that the utility interferences may impact the performance of, and/or interferes with, City work. The Contractor will be required to perform such utility work as directed by the Resident Engineer in order to clear all utility interferences from the project site as required for satisfactory completion of City work within specified contract schedule.
- b) In areas serviced by overhead lines on poles carrying electric, telecommunication and cable system, the Contractor understands and by bidding for this contract agrees that he/she will be required to perform the public work in the presence of energized electrical overhead lines and appurtenances located in areas adjacent and/or within the project area. As a consequence he/she will select means and method of construction appropriate to maintain the safety clearances required or as permitted by electric operators in order to avoid damaging the insulation or shielding of these lines and also to prevent knocking them down.

2. Field inspection prior to construction:

Prior to the start of any contract work in areas serviced by overhead electric lines, and after the award to the apparent low bidder for this contract, the Contractor must request a field walk of the project area along with the operator of the overhead electrical facilities and the DDC Engineer-In-Charge. At that time the facility operator will confirm the type and condition of the overhead electrical lines and the sufficiency of their insulating properties with respect to the means and methods proposed by the Contractor. The Contractor must be prepared to describe in enough details his/her proposed means and methods of construction operations in order to anticipate the likelihood that electric lines insulation would be cut or otherwise compromised. Also such details will allow the facility operator to anticipate the need for added insulation and/or shielding of non-insulated lines.

3. Compensation for interference work:

Compensation for Interference Work is a matter of adjustment between the Contractor and each private utility company located within the limits of the project area and whose utility facilities are affected by City contract work. In particular, the City will not compensate the Contractor for any direct and/or indirect costs related to Interference Work, including, but not limited to, delay, lost profit, increased overhead, or any other impact costs. Upon receipt of a Notice of Award from the City, the Contractor shall immediately commence negotiations with each of the Companies concerning the manner in which and the price for which the Contractor, through its own forces or by others hired by it, will perform and be paid by the Company for all necessary Interference Work as defined above, and at known locations of City contract work, that the Company(ies) choose(s) not to perform with its(their) own forces or by specialty contractors hired by it (them) (as per "Interference Agreement"). Specialty contractors' work is limited to (i) insulation installation and removal, (ii) live gas and steam work, (iii) cleanup and disposal of hazardous materials, (iv) splicing live electrical and telecommunications facilities, and (v) work not traditionally performed by general construction contractors.

4. Interference Agreement:

- a) Although the parties may negotiate an Interference Agreement in any format or manner they deem fit, the Contractor is hereby advised that the Companies have indicated to the City that they will agree to compensate the Contractor on a unit price basis for Types of Interferences encountered on this Contract in accordance to the Private Utilities reference document for SECTION U called "CET SPECIFICATIONS AND SKETCHES", dated November 2010, copy of which is available on demand.
- b) The Contractor shall notify the City upon concluding an Interference Agreement with each of the Companies.

5. City contract work to continue without Interference Agreement :

If, prior to the start of construction, as directed by the City's Order to work / Notice To Proceed (OTW/ NTP) date any of the Companies and the Contractor have not concluded an Interference Agreement as described above, then the City shall issue a written "48 Hours' notice to Public Corporation" as prescribed by the City of New York Administrative Code, commonly referred to as "Order-Outs" and City construction will proceed as ordered and the Contractor will be directed by the Resident Engineer (RE) to perform the City work on Time, Material and Equipment basis (T&M) as specified in standard City contract agreement Article 26.2. T&M records will include identification of types of utility facilities interfering with City work, utility facility owners, specifying the nature and quantity of any materials, plant and equipment furnished or used in connection with the performance of such work and crew size, such as: name and number of each worker employed on such work. T&M records will also indicate the hours of active time, standby time and idle time. The Company (ies) and the Contractor will maintain separate records of the actual quantity and cost of labor, materials, and equipment expended, and will provide copies of this information to the other party on a daily basis for reconciliation. These T&M records along with cost evaluations will be submitted daily to the Resident Engineer for review and approval. The total cost of City work will be based on quantity of work performed multiplied by unit price contract bid items. The total interference cost will be calculated as the difference between the total T&M cost and total cost for City work.

The Resident Engineer will conduct a monthly reconciliation session of the daily T&M records with the affected Company (ies) and the Contractor. If the Contractor and affected utility companies cannot reconcile their T&M records, by the last day of each month, then the Resident Engineer will submit the approved City's T&M records along with total cost evaluations to the DDC Director of Construction who will review these records and recommend approval and validity certification by the DDC Construction Assistant Commissioner.

- a) Copies of the DDC approved and certified T&M records will then be transmitted by the DDC to the Contractor and the utility companies. These certified records may be used by the Contractor for compensation claims against the responsible private facility owners, or may be used by any party as supporting documentation in dispute regarding compensation for performing Interference Work. The Contractor will be required to perform City work while invoices are submitted by the Contractor to the Utility companies for payment within 30 days, or while compensation disputes between the Contractor and affected company (ies) are submitted to Binding Arbitration process described in Paragraph 9.
- b) All issues related to utility work and/or delays due to compensation disputes or claims against utility companies are not allowable as justification for granting contract time extensions or delay claims against the City. The City may assess liquidated damages specified in the contract for net overall delays suffered by City contract work as a result of utility issues, disputes and claims.
- c) The standard City contract dispute resolution process specified in Article 27 "Presentation of disputes to Commissioner", of the standard City contract agreement is not applicable to any disputes related to utility work and/or compensation for such work or claim against utility companies. Utility work issues, disputes and claims may only be submitted to Binding Arbitration process described in Paragraph 9.
- d) The Contractor will notify the Resident Engineer when utility work that require the intervention of company utility specialty crews causes excessive contractor's labor and equipment standby or idleness and, thereby jeopardizing the City project

schedule. The Resident Engineer will submit the facts to the DDC Director of Construction who will recommend to the DDC Deputy Commissioner regarding the issuance of a "48 Hours' notice to Public Corporation" to the concerned utility company as authorized by the New York City Administrative Code Section 19-143 and/or Section 24-521 as applicable.

- e) Utility delays caused by utility and/or by unavailability of utility specialty crews cannot be discounted for earning any contractual bonus when such bonus clause is included in a contract. However, if such specified bonus is not earned or is disallowed by the City or if the City assesses specified liquidated damages as a result of such excessive delays, the Contractor may seek damages from the responsible utility company (ies).

6. *Extra utility work with Interference Agreement:*

If during construction the Contractor encounters utility facilities interferences or utility scope of work that it believes is not covered by the Interference Agreement as described above, then the Contractor shall immediately notify the Company in writing, with a copy to the City, describing the nature and location of the extra work in question. The Company then has five (5) business days to investigate the conditions and then:

- a) Advise the Contractor and the City in writing that no interference with its facilities exists at the location in question, and hence that the Contractor may proceed with City work without providing for any impact from Company facilities;
- b) Advise the Contractor and the City in writing that the Interference Agreement negotiated pursuant to Paragraph 4, provides for the scope of work encountered.
- c) Advise the Contractor and the City in writing that it intends to perform the necessary utility Work with company forces or with its own contractor including, but not limited to, relocating its facility out of the way of the proposed City work. In this case, the Company shall provide a written schedule for the performance of the utility work it proposes to perform, which shall be subject to approval by the City based on its impact to the Contractor's currently approved progress schedule. Upon approval of the Company's schedule by the City, the Contractor

shall provide access to the worksite to the Company and/or any contractors hired by it to perform this utility work. If necessary, the City may grant a contract time extension for delays caused by the performance of such utility work by the company.

- d) Reasonably specify in writing the scope of work to be performed by the Contractor on behalf of the Company that is not covered under the Interference Agreement negotiated pursuant to Paragraph 5, including, but not limited to, relocating, supporting, and/or protecting the Company's facilities, and/or shifting the City facility if approved by the Resident Engineer, and/or otherwise changing its operations to work in the presence of the Company's facilities. Should the Company elect this option, it must adequately define and provide an initial price offer for the work required to be performed.

7. Means and Methods for utility work:

Upon receipt of the Company's determination pursuant to Paragraphs 6.b, or 6.d, above, the Contractor shall determine reasonable means and methods of performing the work defined by the Company. These means and methods are subject to approval of the Company, which shall not be unreasonably withheld. If, however, the Company objects to the Contractor's proposed means and methods then it shall define an alternate method of construction. Upon receipt of the Company's approval or its proposed alternate method of construction, the Contractor shall commence performance of the work defined by the Company as soon as possible, and shall perform the work in a good, workmanlike, and efficient manner, using the means and methods approved by the Company, in order to permit the City work to proceed in the most expeditious manner possible, but without imposing unreasonable and/or unnecessary costs on the Company. It is expressly understood by all parties that the City's rights pursuant to Article 4 of the Contract apply to Utility Work performed pursuant to this Section.

8. Disputed utility work covered by an interference agreement:

The City Work will continue as described in Paragraph 5 above. In the event of any dispute between the Company (ies) and the Contractor regarding any issue related to the

performance of, or payment for, utility work, including, but not limited to, any indirect or impact costs incurred by the Contractor due to the Utility Work and/or to the existence of facilities owned or operated by the Company (ies) on the line of the work. The Company (ies) and the Contractor hereby agree to submit to each other a "Final Offer," in writing, by certified mail. Each party shall then have three business days to consider each other's Final Offer. In the event that neither party accepts the other's Final Offer within those three days, the Company (ies) and the Contractor agree to immediately submit the dispute to binding arbitration as described in Paragraph 9. During the pendency of any arbitration, the Company (ies) and the Contractor shall maintain separate records of the actual quantity and cost of labor, materials, and equipment expended, and to provide copies of this information to the other party on a daily basis for reconciliation. Any and all disagreement with the records maintained and provided by the other, must be documented in writing to all parties. However, these records are solely for the benefit of presentation to the arbitrator, whose decision may not necessarily be based on these records and in any event is final. Both parties should be aware that the City will not confirm or deny the accuracy of any records that is not certified by DDC.. While the arbitration is pending, the Company shall pay the Contractor on a monthly basis, based on the price offered by the Company to the Contractor for the performance of the work.

9. Arbitration of utility work:

The arbitration of the issues described above shall be conducted pursuant to the Construction Industry Arbitration Rules of the American Arbitration Association (hereinafter "the Rules" and "AAA") in effect on the date the arbitration is initiated except as set forth herein. The arbitration award shall be final and binding upon the parties to the arbitration and judgment upon the award may be entered in a court having jurisdiction.

- (a) Once an arbitrator(s) has been appointed by the AAA, the arbitration shall be scheduled as promptly as possible given the arbitrator(s) and the parties' schedules.
- (b) No later than seven days prior to the first arbitration hearing, Company and the Contractor shall submit to the arbitrator(s), and to each other, a summary of each party's respective position and such other information as is deemed appropriate, along with a copy of each party's Final Offer as specified in Paragraph 8.

- (c) The arbitration shall be conducted and concluded in two days.
- (d) On the morning of the first day of the arbitration, the Contractor and/or representatives shall have 3 ½ hours to make a presentation of its claim to the arbitrator. During its presentation, the Contractor shall not be permitted to produce any documents or cost records which have not already been provided to the Company. The Contractor shall be permitted to produce any analysis or description of its claim which has been prepared for the purpose of its presentation.
- (e) Company and/or its representatives shall have two hours to ask the Contractor questions about its claim and its presentation. Thereafter the arbitrator(s) shall have two hours to ask the Contractor questions about its claim and its presentation.
- (f) On the morning of the second day of the arbitration, Company and/or its representatives shall have 3 ½ hours to make a presentation of its claim to the arbitrator. During its presentation, the Company shall not be permitted to produce any documents or cost records which have not already been provided to the Contractor. The Company shall be permitted to produce any analysis or description of its claim which has been prepared for the purpose of its presentation.
- (g) The Contractor and/or its representatives shall have two hours to ask Company questions about its claim and its presentation. Thereafter the arbitrator(s) shall have two hours to ask Company questions about its claim and its presentation.
- (h) Subject to the above time limitations, the arbitrator(s) may conduct the arbitration in such manner as the arbitrator(s) deems reasonable.
- (i) The arbitrator(s) shall then have one week to select in writing, as the arbitrator ('s) award, that party's Final Offer which appears to be more reasonable, based on the presentations at the arbitration hearings.
- (j) The arbitrator shall have no discretion to grant an award other than one of the two Final Offers submitted by the parties.
- (k) Any award for work that has already been performed shall be paid on the 7th day after receipt of the arbitrator's decision, or on the 30th day after completion of the work, whichever is later. Payment for work not yet completed at the time of the arbitrator's decision shall be paid within 30 days of completion of work. Interest shall accrue from the date payment is due at the rate of 9% per annum. Either party may

cause judgment to be entered in accordance with the arbitrator(s) decision in a court in the State of New York, County of New York.

- (l) The arbitrator's fees and any other costs of the arbitration shall be initially shared equally by Company and the Contractor. The non-prevailing party shall then pay all arbitrator's fees and costs of the arbitration and shall reimburse the prevailing party for its share of such fees and costs theretofore paid.
- (m) The parties may, at any time, settle any matter submitted to arbitration.

10. Order-out waiver:

The Contractor and all subcontractors hired by it, if an Interference Agreement is executed as specified between the concerned parties, agree to waive any rights they may have, if any, under law, contract or otherwise to compel the City to assert any right the City may have, including the issuance of any directives required under the New York City Administrative Code, Section 19-143 and Section 24-521, to require any or all of the Companies to maintain, repair, replace, protect, support, shift, alter, relocate, and/or remove utility facilities in connection with the work to be performed under this contract. However, nothing in this Section shall preclude the City from exercising its rights under the Law to issue such a directive to the Company.

11. Cost of insurance:

Each of the named Companies, at their option and if an Interference Agreement is executed as specified between the concerned parties, may be named as an additional insured on all insurance policies required to be maintained under this contract. In the event that a Company opts to be so named as an additional insured, the actual incremental cost, if any, to the Contractor of providing such insurance coverage shall be borne by that Company. The Contractor shall provide a written statement from its insurance provider documenting the actual cost of this added coverage to the Company. Under no circumstances shall the cost of insurance coverage on behalf of any Company be borne by the City. Nothing in this paragraph shall be interpreted to imply the City's acceptance of any additional responsibility or liability for any matter related to the performance of Utility Work. In particular, the Company and the Contractor bear joint and full responsibility to ensure that any Utility Work performed by the Contractor is in compliance with all applicable government and Company regulations.

12. Cost of utility interference work:

The Companies, by virtue of a prior agreement with the City, have agreed to perform their obligations described in this section. It is expressly understood that the cost of Utility Work or any delays cost caused by such utility work shall not be a charge against the City, but shall be a matter for adjustment between the Contractor and the Company or Companies concerned. The City and the Contractor agree that the Companies are third party beneficiaries of this Section of the contract, if an Interference Agreement is executed between the Contractor and utility company (ies). The provisions of this Section shall govern in all cases where Company property interferes with or is about to be disturbed by the City work, notwithstanding any other provision of the Contract, except for Natural Gas transmission/distribution facilities covered subject to the Gas Facility Cost Allocation Act (GFCAA) and covered separately in this contract.

13. Default declaration:

The Contractor agrees that the provisions of this Section are material provisions of the contract, and that the Contractor's failure to comply with the procedures set forth above are sufficient for the Commissioner to declare the Contractor in default pursuant to Article 48 of the Contract.

14. NYS Labor Law:

The Contractor is hereby advised that New York State Labor Law and/or, Davis-Bacon Act if federally funded, applies to public work. The work described in this Section U of the contract performed by utility company (ies) with their own forces or vendors hired by such company (ies) is not public work.

15. Facility operators:

The insurance requirements in Paragraph 11 of this Section U apply to: (i) additional Companies, if any, who were not named in Schedule "A" but which have executed an Interference Agreement with the Contractor for utility work; and (ii) additional coverage, if any, paid for by Utility Companies whose utility facilities are located within the project limits, that they may require for the utility work pursuant to an Interference Agreement between the Contractor and such utility company (ies).

[End]

"STANDARD UTILITY LETTER OF AGREEMENT"

(Name)
Deputy Commissioner, Infrastructure Division
Department of Design and Construction
30-30 Thomson Avenue
Long Island City, NY 11101

RE: City Work Performed in the Presence of Private Utility Facilities
Project No: _____

Dear (Name):

This letter is to certify that _____, has requested the inclusion of the attached "Section U: Additional contract requirements applying to work performed in the presence of privately owned utility." The company agrees to abide by the terms of this Section U at the company's own expenses due to their facilities interferences with the Public work.

Sincerely,

By: Authorized Company Representative

Title

NOTARY PUBLIC

CERTIFIED AS TO FORM
AND LEGAL AUTHORITY:

By: _____

SCHEDULE U-1

LISTING OF COMPANIES NAMED FOR THIS CONTRACT

<u>COMPANY NAME</u>	<u>CONTACT NAME</u>	<u>CONTACT TELEPHONE</u>
CON EDISON	O'NEILL WRIGHT	212-460-3870
Charter Spectrum	JOHN PIAZZA	718-888-4261

SCHEDULE U-3

(NO TEXT IN THIS SECTION)

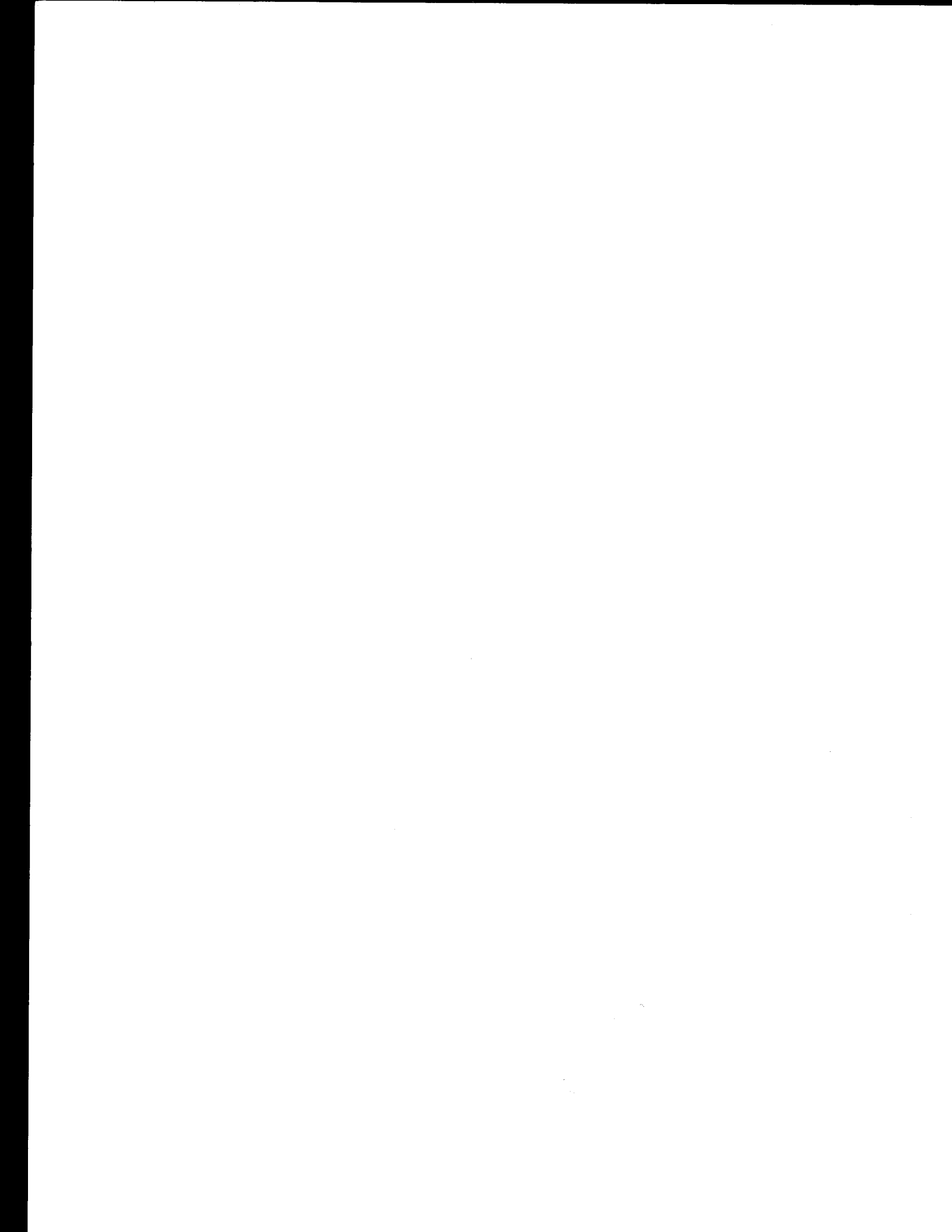



**Department of
Design and
Construction**

**DIVISION OF INFRASTRUCTURE
BUREAU OF DESIGN**

VOLUME 3 OF 3

PROJECT ID: SEQBN11

RECONSTRUCTION OF EXISTING SEWERS, NORTH QUEENS

**Together With All Work Incidental Thereto
BOROUGH OF QUEENS
CITY OF NEW YORK**

Contractor

Dated _____, 20____
